

SENTINEL V

REAL-TIME

DECK BOX

USER'S GUIDE



P/N 95D-6045-00 (April 2018)

© 2018 Teledyne RD Instruments, Inc. All rights reserved.

Information included herein is controlled by the Export Administration Regulations (EAR) and may require an export license, license exception or other approval from the appropriate U.S. Government agency before being exported from the United States or provided to any foreign person. Diversion contrary to U.S. law is prohibited.

TABLE OF CONTENTS

DECK BOX OVERVIEW1
CONNECTING TO THE ADCP4
CABLE WIRING DIAGRAMS.....6
INSTALLING THE DRY-SIDE CONNECTOR13
SPECIFICATIONS.....15

Deck Box Overview

This booklet shows how to connect the Sentinel V Real-Time Deck Box cables. The Deck Box contains all interfaces to/from the Sentinel V Real-Time ADCP, computer, and power.

Overview

Power Switch – Press the power switch to apply power to the ADCP. The LED on the switch lights when power is applied to the Deck Box.

Transmit/Receive LEDs – **Receive** indicates data transmission from the ADCP to the computer. **Transmit** indicates data transmission from the computer to the ADCP.



ADCP (J1) – Connects the ADCP to the Deck Box.

Ethernet (J2) – Connects the computer Ethernet port to the Deck Box.

RS 422 (J3) – Connects the computer's RS-422 port to the Deck Box.

RS 232 (J4) – Connects the computer RS-232 port to the Deck Box.



The Deck Box will convert RS-232 to RS-422.

Fuse (J5) – Protects the Deck Box from excessive input power.

AC Power Input (J6) – The deck box accepts input voltages of 88-264 VAC, 50-60Hz. This input voltage will be converted to 16 VDC. This is the voltage supplied to the ADCP.

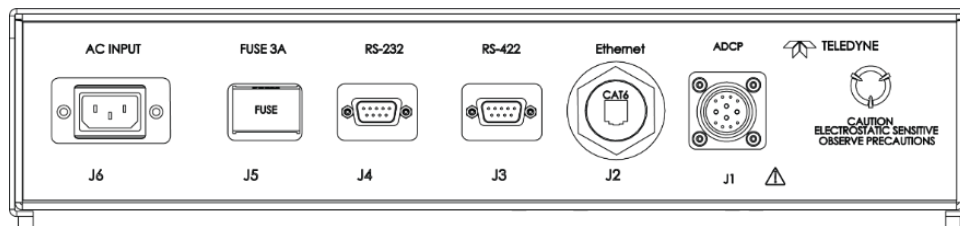

Safety Warnings



RISK OF ELECTRIC SHOCK - High Voltage Warning:

Dangerous voltage are present within the Deck Box. Do not operate with the cover removed.



Complete the ground path. The power cord and the outlet used must have functional grounds. Before main power is supplied to the Deck Box, the protective earth terminal of the Deck Box must be connected to the protective conductor of the mains power cord. The power cord plug shall only be inserted in a socket outlet provided with a protective earth contact. The protective action must not be negated by the use of an extension cord (power cable) without a protective conductor (grounding). Grounding one conductor of a two-conductor outlet is not sufficient protection.



If the Deck Box power is supplied via an auto-transformer, make sure the common terminal is connected to the earth terminal of the power source.



Any interruption of the earthing (grounding) conductor, inside or outside the Deck Box, or disconnecting the protective earth terminal will cause a potential shock hazard that could result in personal injury.



Do not operate the Deck Box in the presence of flammable gasses or fumes. Operation of any electrical instrument in such an environment constitutes a definite safety hazard.



Do not place objects (laptops, electronics or EMI sensitive equipment, coffee cups, etc.) on top of the deck box.

Deck Box Mounting Considerations

Place the Deck Box where there is access to the cables and host computer. Allow enough room around the Deck Box for access, ventilation, and isolation from electronic and magnetic interference.

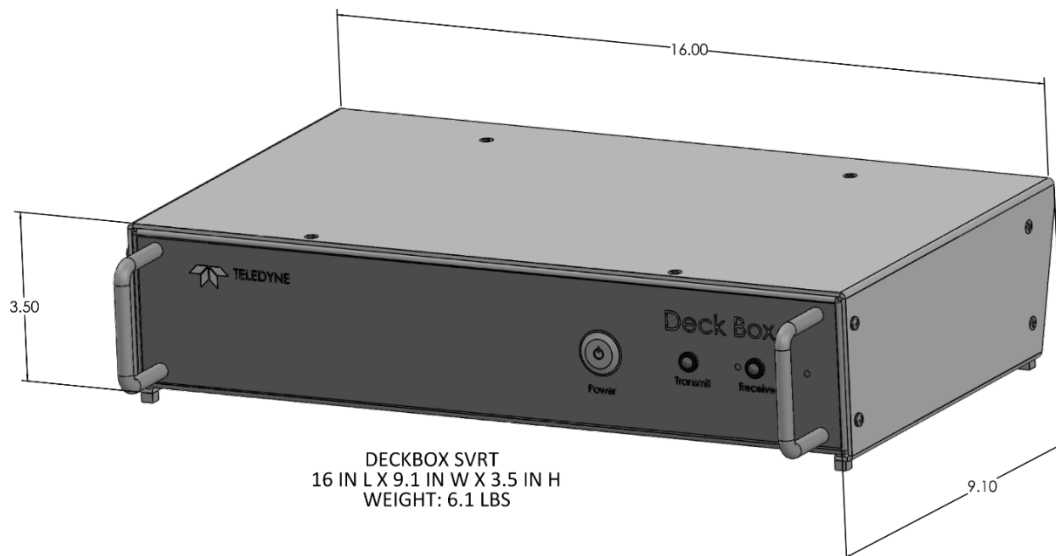

The Deck Box is designed to fit in a 2U rack mount or mounted to a desk using the optional mounting brackets (Accessory kit 70DK6001-00).

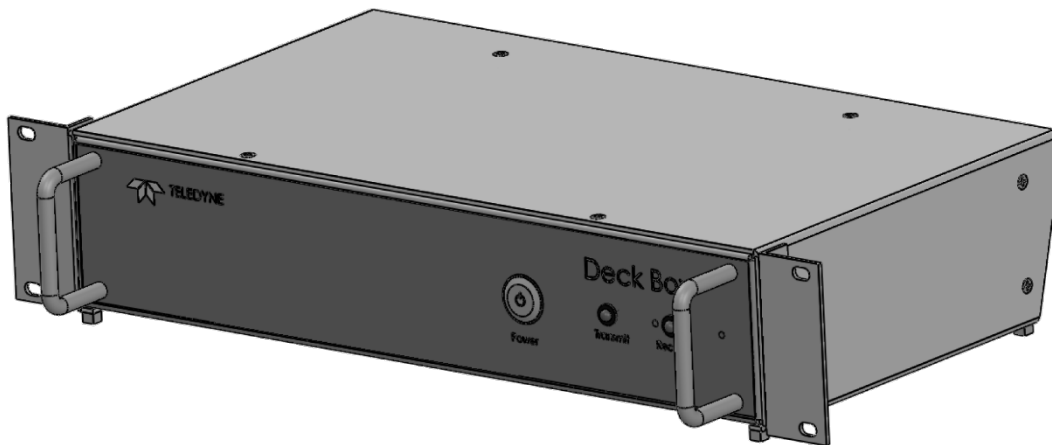

DECKBOX SHOWN WITH OPTIONAL RACK MOUNTS

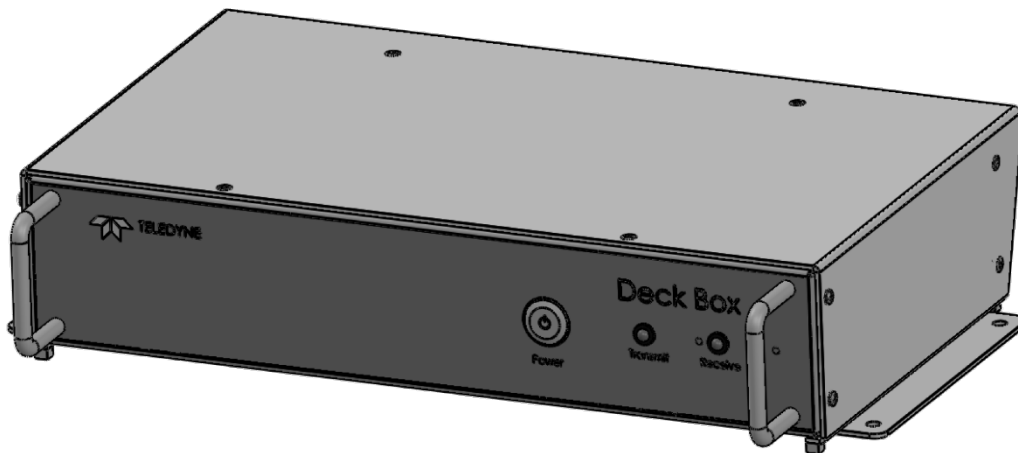

DECKBOX SHOWN WITH OPTIONAL BENCH MOUNTS

Table 1. Accessory kit 70DK6001-00

Part Number	Part Description	Quantity Per Assembly
#6WASHMOD	WASHER,FLAT,#6 SST .156 IDx.275 ODx.049 THK	4
#6WASHSPL	WASHER,SPLIT LOCK #6 SST	4
6-32X1/2PH	SCREW, PAN HEAD, SST	4
81D-6017-00	BRACKET, RACK MOUNTING, SVRT	2
81D-6019-00	BRACKET, BENCH MOUNTING, DECKBOX, SVRT	2
8-32X1/2FHSH	SCREW, FLAT HD, HEX DRIVE 100 DEG, 316SST	4
BK/GMD-3-R	FUSE, 3A 250VAC 5X20mm	1

Connecting to the ADCP

Connecting to the ADCP using Ethernet

1. Attach the ADCP cable to J1 and the Sentinel V ADCP.
2. Connect the computer to the Deck Box using the Ethernet (J2) connector and CAT6 cable.
3. Attach the power cord to J6 and then press the Power button on the front panel.
4. Use *Sentinel V RT Utilities* software and connect to the system using the Ethernet port. Following the instructions in the Sentinel V SC_RT Operation manual, chapter 1A.



For more information on *Sentinel V RT Utilities*, click the Help icon  to open the Sentinel V RT Utilities Software help file.

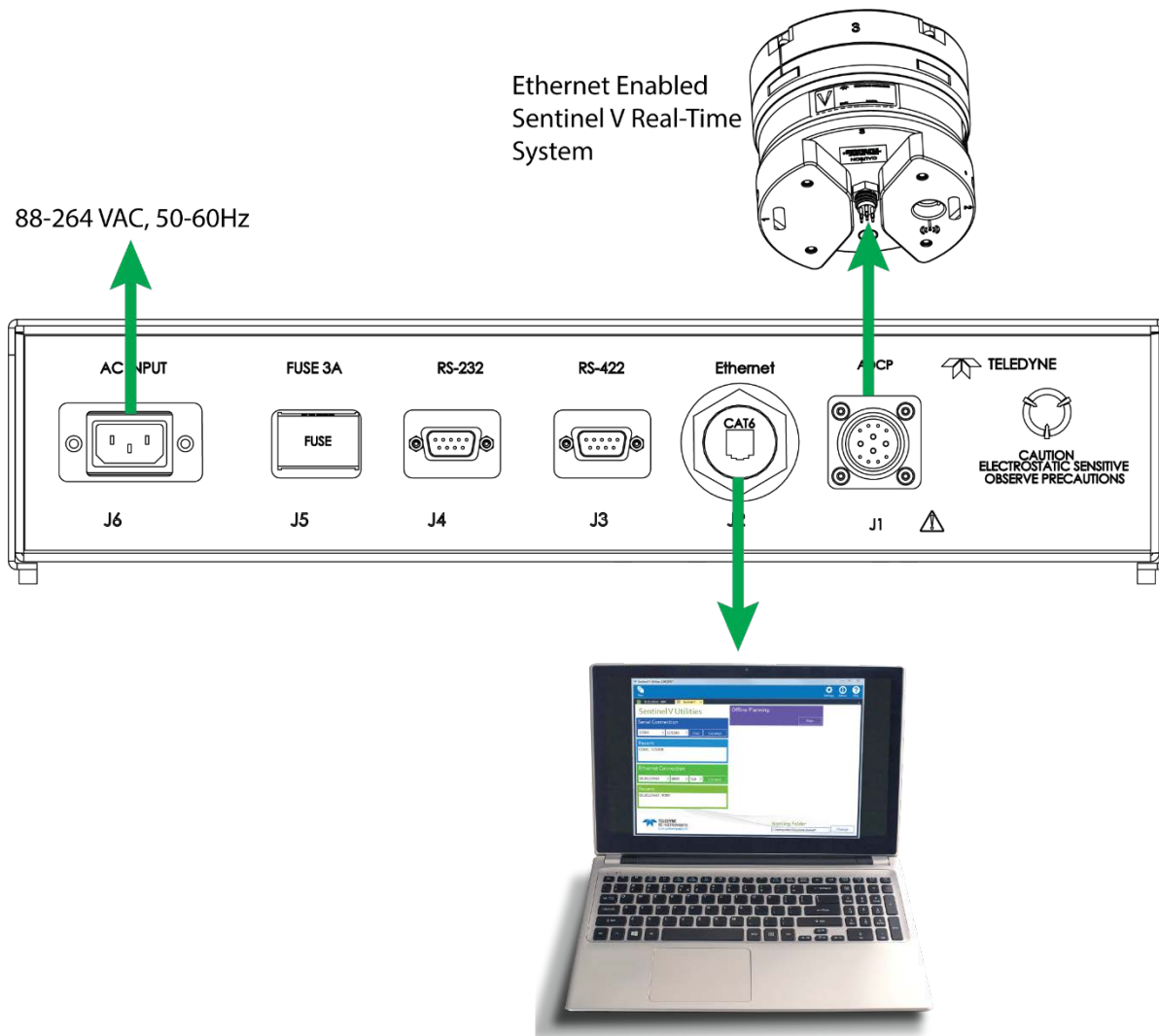

Connecting to the ADCP using Serial

1. Attach the ADCP cable to J1 and to the Sentinel V ADCP.
2. Connect the computer to the Deck Box using the RS-422 (J3), or RS-232 (J4) connector. The Deck Box will convert RS-232 to RS-422. Communications to the ADCP is always RS-422.



RS-232 or RS-422 can be connected to Deck Box depending on the length of the serial cable. For cables up to 15 meters, use a RS-232 cable connected to the RS-232 connector (J4); for cables over 15 meters, use a RS-422 cable connected to the RS-422 connector (J3) and a 73B-6000-00 RS-422 to RS-232 converter connected to the computer's Com port.



Only connect one output port, J3 or J4, not both.

3. Attach the power cord to J6 and then press the Power button on the front panel.
4. Use *Sentinel V RT Utilities* software and connect to the system using the Serial port. Following the instructions in the Sentinel V SC_RT Operation manual, chapter 1A.



For more information on *Sentinel V RT Utilities*, click the Help icon () to open the Sentinel V RT Utilities Software help file.

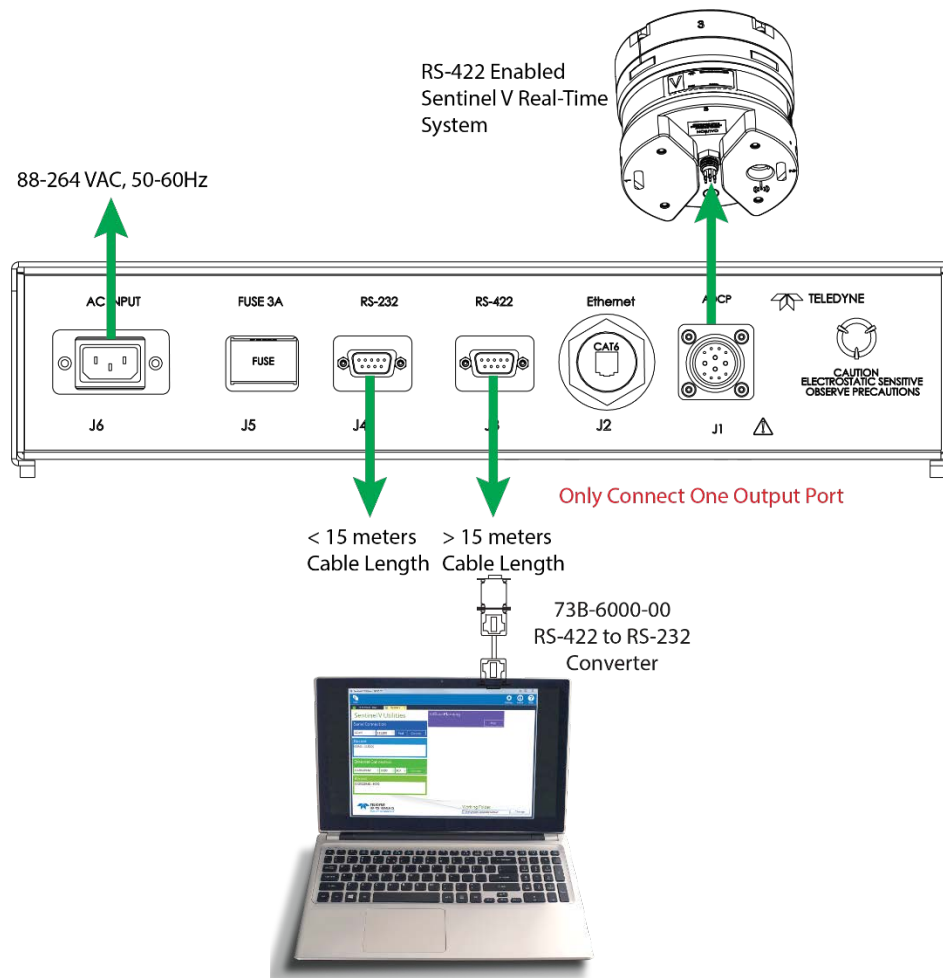

Cable Wiring Diagrams

The ADCP cable connects the transducer assembly to the deck box. This cable is typically pulled through the vessel inside of conduits that may be unable to accommodate the dry-end connector. To facilitate installation through conduits, the cable can be provided without the dry-end connector installed (pigtail). Once the cable has been pulled through the vessel, the dry end connector is installed. The pigtail version cable connector is delivered in a bag with the associated pins, backshell, and hardware for installation at the customer site.



Depending on the system communications and the cable length, the wire gauge for the power pins is either 14awg or 18awg. Use the following tables to identify the cable part number for your system.

Table 2. RS 422 Version Cables with Both Connectors Installed

		Model Number		
		V100	V50	V20
Cable length	5	73D-6025	73D-6025	73D-6025
	10	73D-6025	73D-6025	73D-6025
	25	73D-6025	73D-6025	73D-6025
	40	73D-6023	73D-6025	73D-6025
	50	73D-6023	73D-6025	73D-6025
	100	73D-6023	73D-6023	73D-6025

Table 3. RS 422 Version Cables with Wet-End Connector Installed (Pigtail)

		Model Number		
		V100	V50	V20
Cable length	5	73D-6035	73D-6035	73D-6035
	10	73D-6035	73D-6035	73D-6035
	25	73D-6035	73D-6035	73D-6035
	40	73D-6033	73D-6035	73D-6035
	50	73D-6033	73D-6035	73D-6035
	100	73D-6033	73D-6033	73D-6035

Table 4. Ethernet Version Cables with Both Connectors Installed

		Model Number		
		V100	V50	V20
Cable length	5	73D-6024	73D-6024	73D-6024
	10	73D-6024	73D-6024	73D-6024
	25	73D-6024	73D-6024	73D-6024
	40	73D-6022	73D-6024	73D-6024
	50	73D-6022	73D-6024	73D-6024
	100	73D-6022	73D-6022	73D-6024

Table 5. Ethernet Version Cables with Wet-End Connector Installed (Pigtail)

		Model Number		
		V100	V50	V20
Cable length	5	73D-6034	73D-6034	73D-6034
	10	73D-6034	73D-6034	73D-6034
	25	73D-6034	73D-6034	73D-6034
	40	73D-6032	73D-6034	73D-6034
	50	73D-6032	73D-6034	73D-6034
	100	73D-6032	73D-6032	73D-6034

73D-6022 Cable U/W, Ethernet, 14 AWG

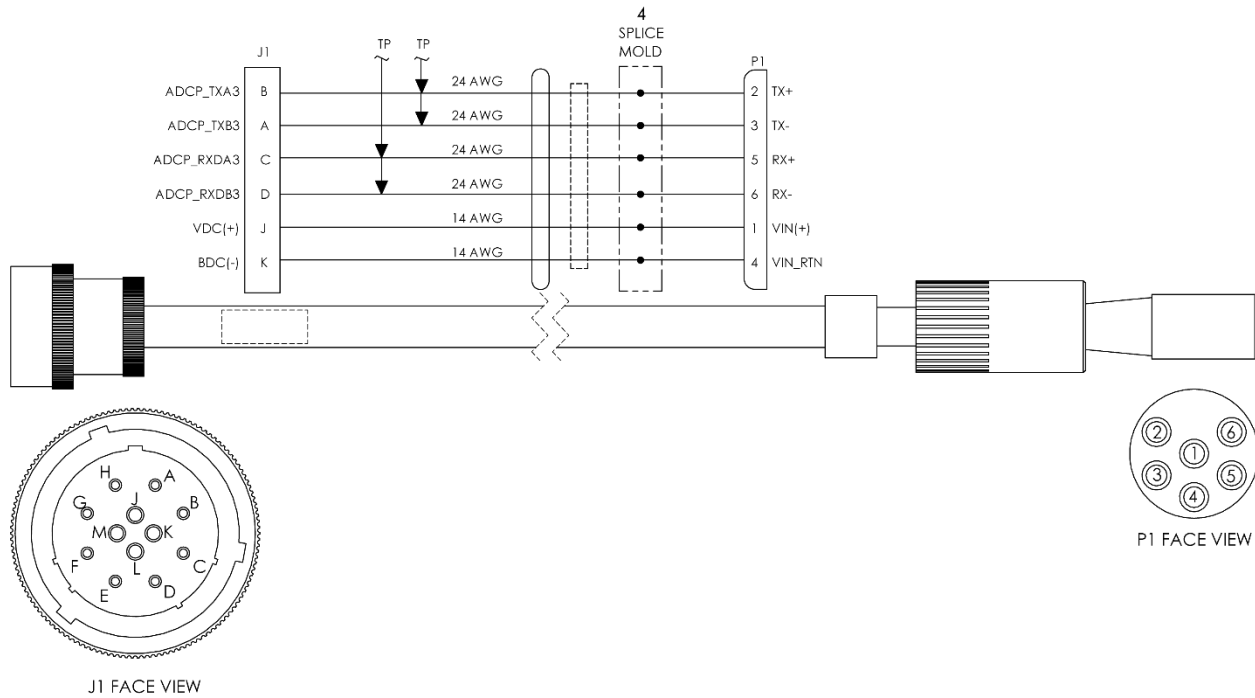

TP = Twisted Pair

73D-6023 Cable U/W, RS422, 14 AWG

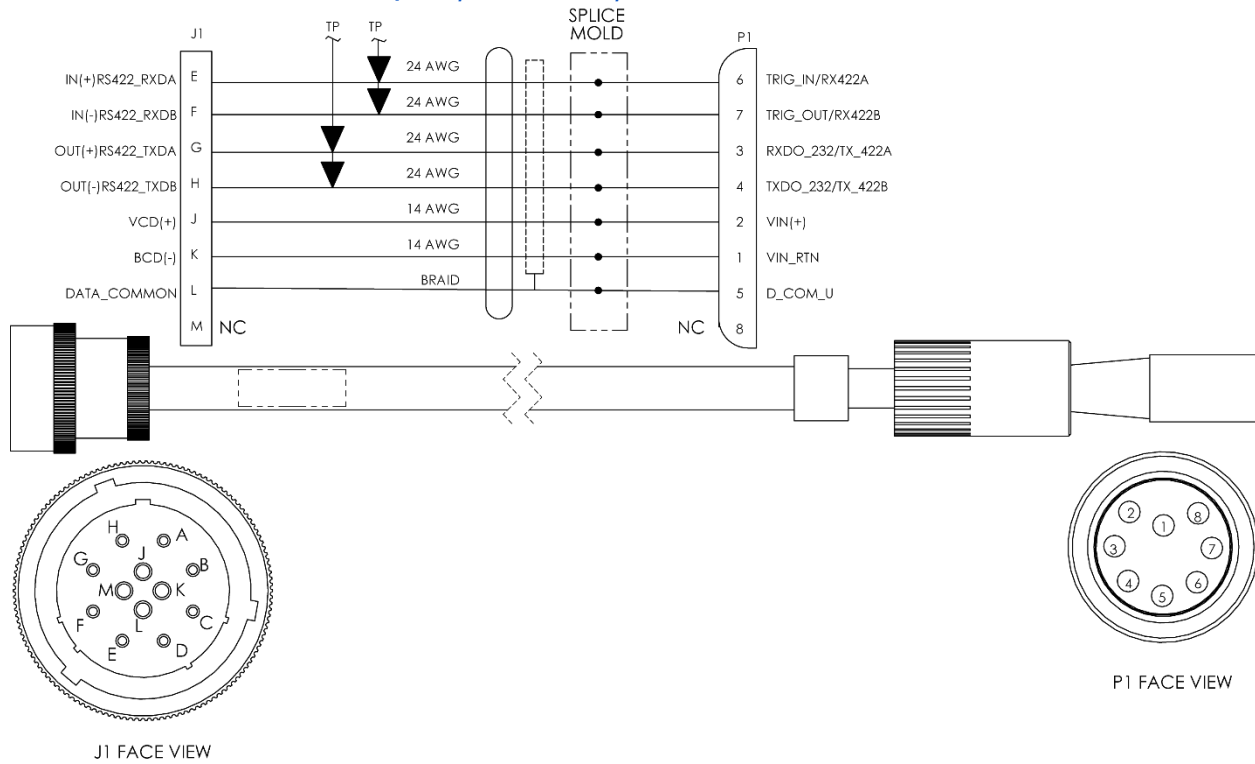

TP = Twisted Pair

73D-6024 Cable U/W, Ethernet, 18 AWG

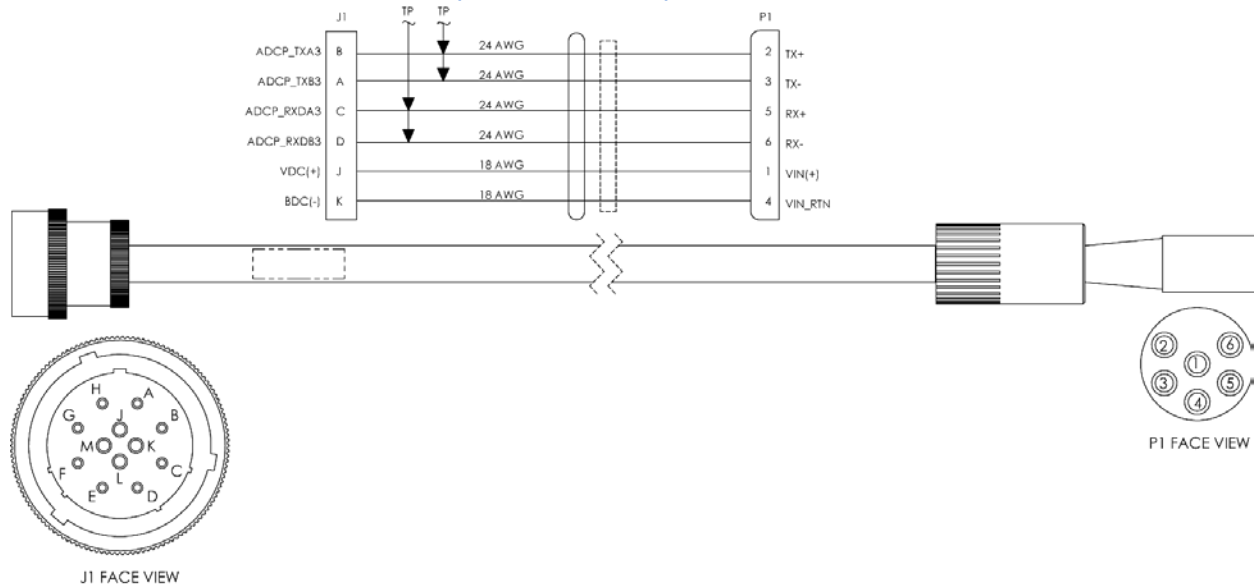

TP = Twisted Pair

73D-6025 Cable U/W, RS-422, 18 AWG

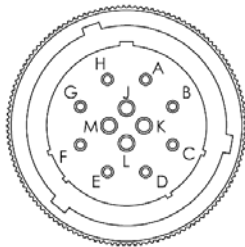
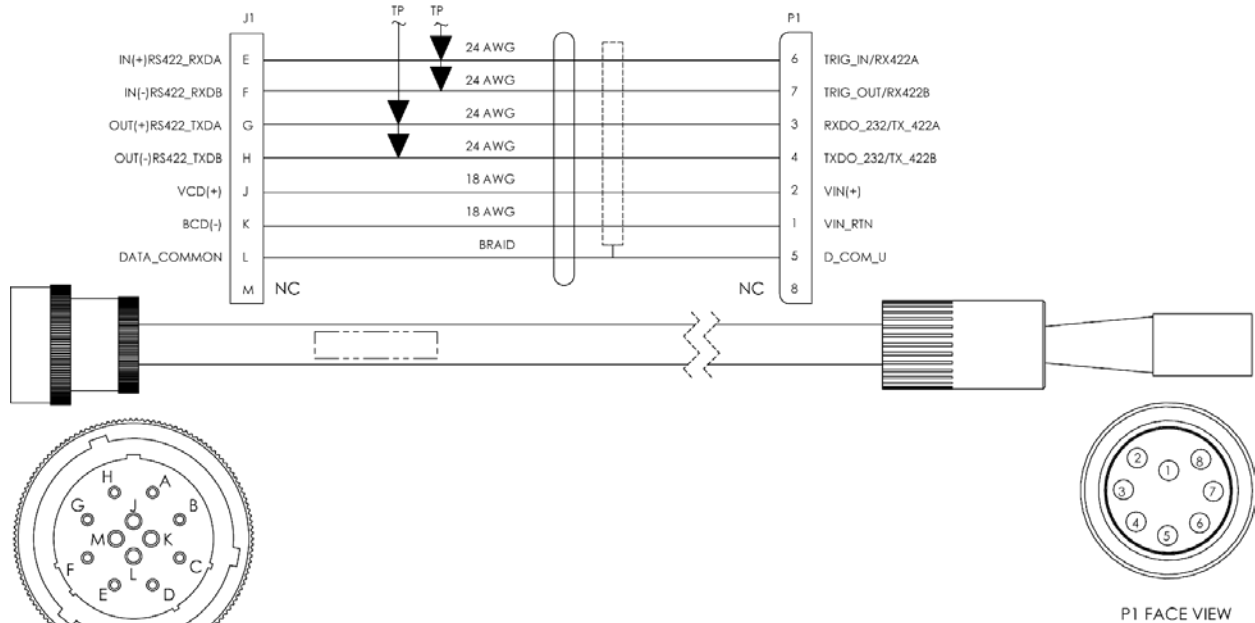

J1 FACE VIEW

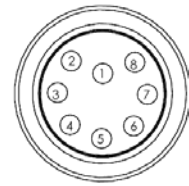

P1 FACE VIEW

TP = Twisted Pair

73D-6032 Cable U/W, ETHERNET, 14 AWG, Pigtail

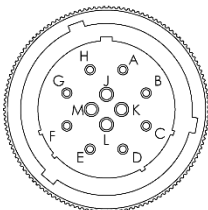
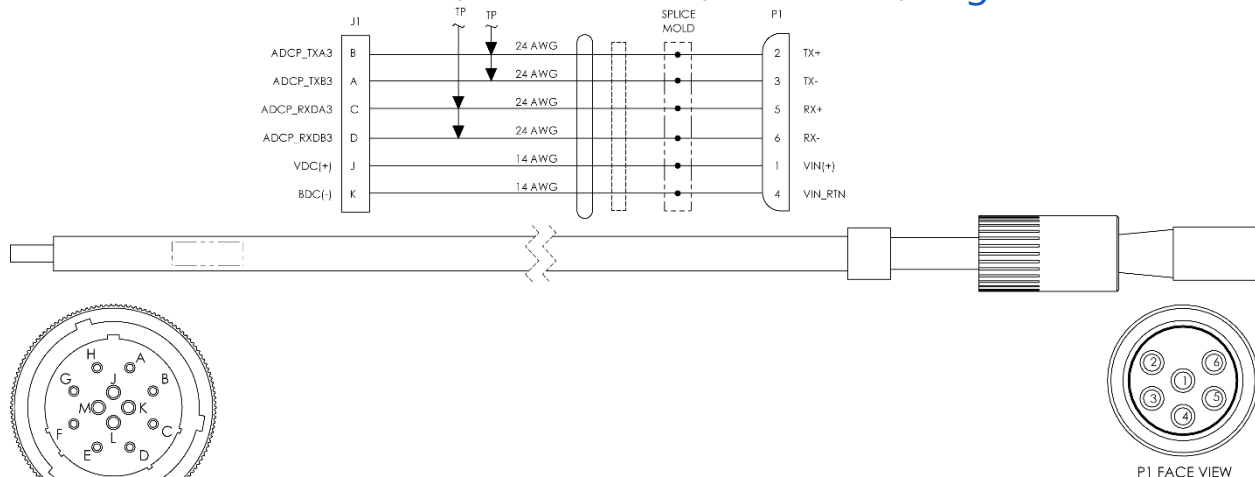

J1 FACE VIEW

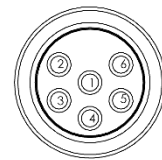

P1 FACE VIEW

TP = Twisted Pair

73D-6033 Cable U/W, RS422, 14 AWG, Pigtail

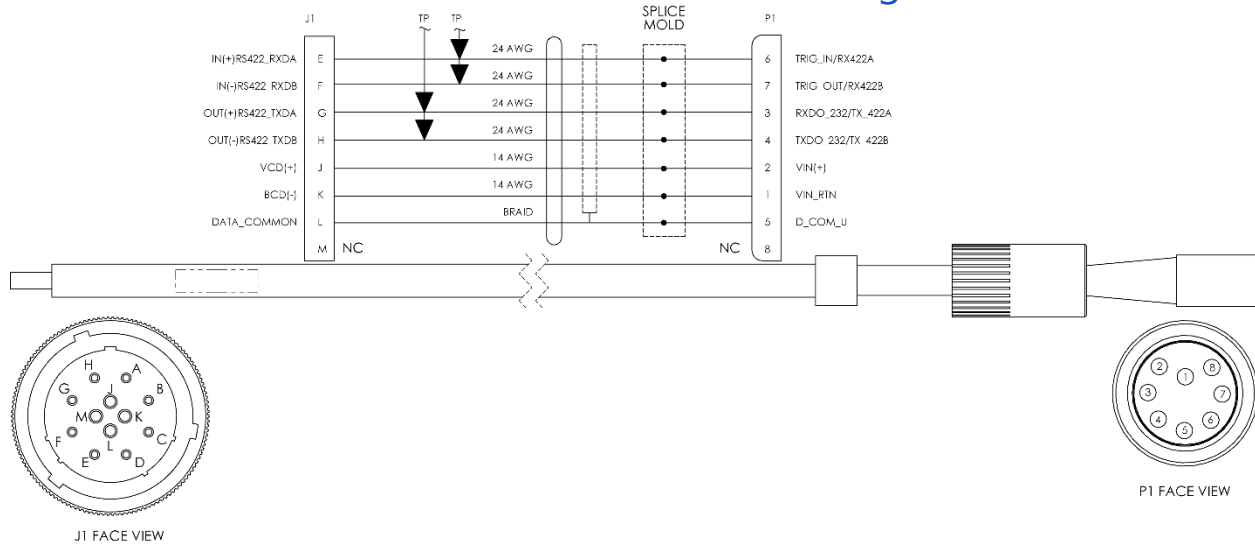

TP = Twisted Pair

73D-6034 Cable U/W, Ethernet, 18 AWG, Pigtail

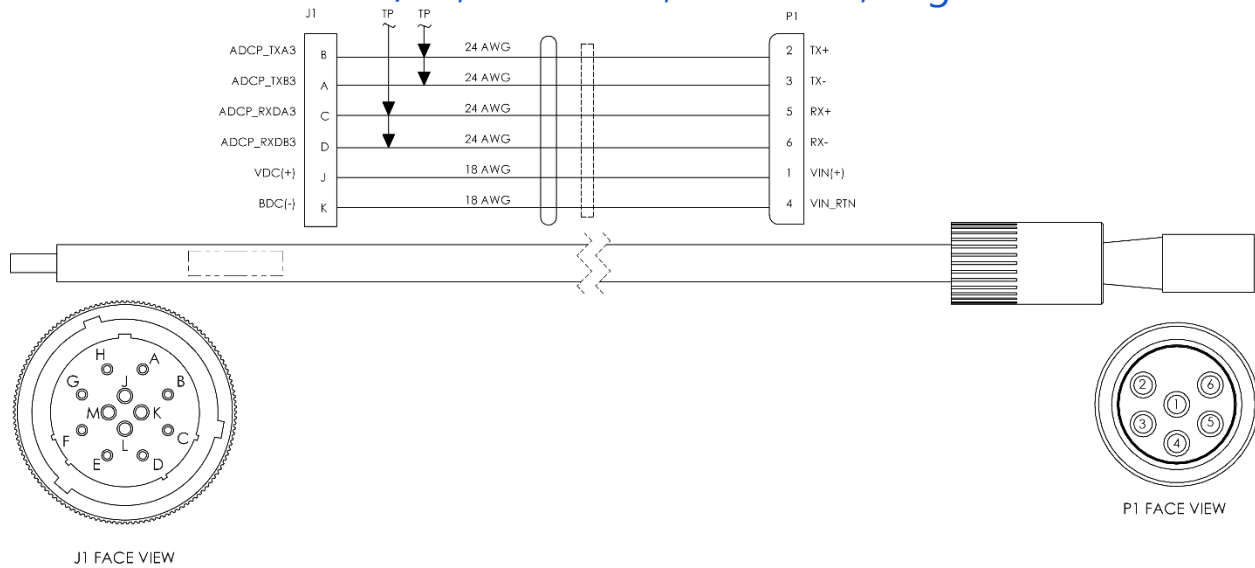

TP = Twisted Pair

73D-6035 Cable U/W, RS422, 18 AWG, Pigtail

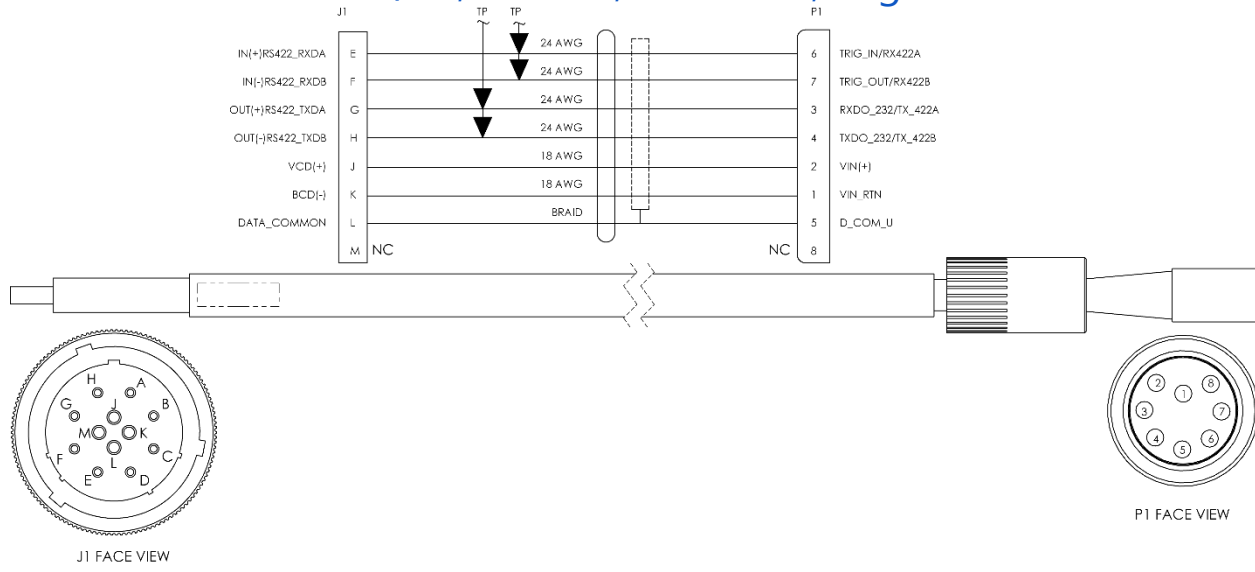

TP = Twisted Pair

Deck Box to Computer Cables



The deck box to computer RS-232, RS-422, and Ethernet cables are user supplied.

RS-232 (J4) Signals

DB9 connector (J4) side	Signal Name
2	Tx
3	Rx
5	GND

Cable must be less than 25 meters in length

RS-422 (J3) Signals

DB9 connector (J3) side	Signal Name
Pin 9	Tx+
Pin 8	Tx-
Pin 2	Rx-
Pin 3	Rx+
Pin 5	Gnd

Ethernet (J2) Signals

Pin number on RJ45 cable	Signal name
2	Tx-
1	Tx+
3	Rx+
6	Rx-

Installing the Dry-Side Connector

Equipment Needed

Tools/Equipment	Part number	Comments
Crimp tool	AF8 (M22520/1-01)	DMC,
insertion tool	85106E1412p50	526 Thorpe Road, Orlando, FL 32824-8133 USA Tel: 407-855-6161 Email: dmc@dmctools.com https://www.dmctools.com/Products/standard_adjustable_crimp_tool.html
Wire cutter		Support 14 to 24 AWG
Wire stripper		Support 14, 18 AWG, and 24AWG
Measuring tape		
Multimeter		
Heat Shrink Tubing		

To install the dry end cable connector:

1. Carefully remove the cable jacket and shield 0.5 inches from the dry end of the cable. Slide on a 76.2 mm (3 inch) length of heat shrink tubing. Using a heat gun, shrink the tubing around the end of the cable. Add a second layer of heat shrink tubing to strengthen the cable.
2. Strip back the individual wire ends of the cable approximately 0.2 inches long using a wire stripper.
3. Set the crimp tool to 16 as shown below for 18AWG wires, 12 for 14AWG wires, and 20 for 24AWG wires.





Set the crimp tool to 16 for 18AWG wires, 12 for 14AWG wires, and 20 for 24AWG wires.

4. Insert a pin into the crimp tool AF8 (M22520/1-01).
5. Crimp the pin onto the wire using the settings mentioned above and as shown below.



6. Insert the wires into positions A through L on the 12-pin Souriau connector (Part Number S85106R1412P50-ND) using the insertion tool (PN 85106E1412p50). Insert the pins from the center of the connector and work your way out. This makes it less likely to bend or break the wires off the pins.
7. Connect the cable clamp. Insure the cable clamp will grip the cable's black polyurethane jacket (covered with the two layers of heat shrink tubing), not the single wires.

Checking the Wiring

After the connector is installed, use a multi-meter to confirm that the connector has been wired properly by performing an end-to-end continuity and adjacent pin isolation check.

1. Confirm that no pins in the dry-end connector are shorted. Check for >two Mohms of resistance between each of the dry-end pins.
2. Check the continuity of the associated dry-end pin to the wet-end of the cable using a multi-meter.

Specifications

Item	Specification
Input voltage on J6	88-264 VAC, 50-60Hz
Voltage output on J1	16V
Input Power (during transmit)	150 W Maximum
Storage temperature range	-30 to 60C
Operating temperature range	-5 to 45C
Maintenance	None required

NOTES