

# WORKHORSE

## SENTINEL, MONITOR, & MARINER OPERATION MANUAL



P/N 957-6150-00 (March 2024)

© 2024 Teledyne RD Instruments, Inc. All rights reserved.



<https://teledynemarine.com>

### Use and Disclosure of Data

Information contained herein is classified as EAR99 under the U.S. Export Administration Regulations. Export, reexport or diversion contrary to U.S. law is prohibited.



**TABLE OF CONTENTS**

**CHAPTER 1 - AT A GLANCE ..... 1**

- Workhorse and Workhorse II ..... 2
- System Overview ..... 3
- WorkHorse Models and Options ..... 4
  - WorkHorse Monitor ..... 4
  - WorkHorse Sentinel ..... 4
  - WorkHorse Mariner ..... 5
  - WorkHorse Options ..... 5
- Mariner Deckbox Overview ..... 7
- Mariner Triggering Function ..... 9
  - Using the Modified Deckbox with Trigger ..... 9
  - Communication Setup ..... 9
  - Baud Rate Setup Considerations ..... 9
  - Trigger Signals, Breaks, and Commands ..... 10
  - Injecting a Trigger Signal ..... 10
  - Verify Triggering on The Bench ..... 10
- Computer Considerations ..... 11
- Power Overview ..... 12
  - Monitor/Sentinel Power Considerations ..... 12
  - Sentinel Internal Battery Power Overview ..... 13
    - Optional Lithium Battery Pack ..... 14
  - Mariner Power Overview ..... 14
- Setting up the WorkHorse System ..... 15
  - Set Up the Monitor/Sentinel ADCP ..... 15
  - Set Up the Mariner ADCP ..... 17
  - Set Up the Mariner ADCP with Trigger In ..... 18
  - Connecting to the System using TRDI Toolz ..... 19
  - How do I know if I have a WH or WHII? ..... 19
  - Changing the Baud Rate in the ADCPs ..... 20
- Caring for your Workhorse System ..... 21
  - General Handling Guidelines ..... 21
  - Assembly Guidelines ..... 21
  - Deployment Guidelines ..... 22

**CHAPTER 2 - INSTALLATION ..... 23**

- Mounting the Instrument ..... 24
- I/O Cable and Dummy Plug ..... 25
  - Using the Cable Clips ..... 26
- Connecting the External Battery Case ..... 27
- Routing Cables ..... 29
- Cable Wiring Diagrams ..... 31
- Bottom Mounts ..... 35
- Buoy Mounts and Load Cages ..... 36
- Over-the-Side Mounting ..... 37
  - Over-the-Side Mounting Special Considerations ..... 38
- In-Hull Mounting ..... 39
  - Transducer Head Mounting Considerations ..... 39
  - Mounting Plate Overview ..... 39
    - Location ..... 39
    - Sea Chest In-Hull Mounting ..... 39
    - Mounting Considerations ..... 42
      - Orientation ..... 42
      - Fairing ..... 42
      - Acoustic Window ..... 42

Free Flow and Windows.....	43
Air Bubbles.....	44
Flow Noise .....	45
Corrosion and Cathodic Disbondment .....	45
Ringing .....	45
Acoustic Isolation.....	46
Maintenance.....	46
Mariner Deckbox Mounting Considerations .....	47
Navigation Interface Considerations.....	47
Installation Procedures (Overview).....	47
Alignment Procedures (Overview) .....	49
<b>CHAPTER 3 – COLLECTING DATA.....</b>	<b>51</b>
Collecting Self-Contained Data.....	52
Collecting Real-Time Data .....	53
<b>CHAPTER 4 - MAINTENANCE.....</b>	<b>55</b>
Parts Location Drawings.....	56
High-Pressure Parts Location Drawings.....	61
Maintenance Schedule.....	62
Calibration Items .....	62
Maintenance Items .....	63
Spare Parts .....	64
Disassembly and Assembly Procedures .....	67
End-Cap Removal Procedures .....	68
Transducer Head Assembly Removal .....	69
WorkHorse Re-assembly .....	70
O-ring Inspection and Replacement.....	70
End-Cap Replacement .....	71
Transducer Head Assembly Replacement .....	72
High Pressure Housings.....	73
High-Pressure Housing Disassembly .....	73
High-Pressure End-Cap Removal Procedures.....	73
High-Pressure Transducer Head Assembly Removal.....	74
High-Pressure WorkHorse Re-assembly.....	75
High-Pressure O-Ring Inspection & Replacement.....	75
Purge Plug Inspection & Replacement.....	77
High-Pressure End-Cap Replacement .....	78
High-Pressure Transducer Head Replacement .....	79
Replacing the Sentinel Battery Packs .....	80
Replacing the External Battery Case Packs.....	82
WorkHorse Lithium Battery Packs.....	82
Power on Cycle.....	83
AC Power Adapter .....	83
Testing the Lithium Battery Pack.....	84
Calibrating the Compass .....	84
Compass Background .....	85
Preparing for Calibration .....	85
WHII ISM Compass Calibration.....	86
WHII ISM Compass Post Calibration.....	88
WH Flux Gate Compass Calibration Verification .....	90
WH Flux Gate Compass Calibration .....	90
Single-Tilt Compass Calibration Procedure .....	92
Mariner Adapter Plate .....	93
Installing the Adapter Plate.....	93
Removing the Adapter Plate .....	95
Periodic Maintenance Items .....	96
Replacing the Desiccant Bags .....	96



Cleaning the Thermistor Cover.....	97
Cleaning the Pressure Sensor Port .....	98
Formatting the CompactFlash Memory Card .....	100
Replacing the CompactFlash Recorder.....	100
Replacing the PC Card Recorder.....	101
Installing Firmware Upgrades .....	102
Installing Feature Upgrades .....	102
Replacing Fuses .....	103
Changing Communications Setting .....	104
Preventing Biofouling.....	104
Antifouling Paints.....	105
Applying Antifouling Paints.....	105
Removing Biofouling.....	106
Zinc Anode Inspection and Replacement.....	107
Zinc Anode Inspection.....	107
Zinc Anode Electrical Continuity Check.....	107
Zinc Anode Replacement .....	107
Protective Coating Inspection and Repair .....	108
Installing the Workhorse II Spare Boards Kit.....	110
Remove the Original Set of Boards .....	111
Installing the Beam Cosine Matrix .....	113
Installing the Pressure Sensor Coefficients .....	114
Testing the System After Board Replacement .....	114
Replacing the End Cap Connector .....	115
Equipment Provided.....	115
Customer Supplied Additional Equipment .....	115
Removing the End-Cap Connector .....	116
Installing the New End-Cap Connector.....	117
Wiring Diagrams.....	119
Replacing the CPU Lithium Battery .....	120
Testing the Lithium Battery Voltage.....	121
Replacing the Lithium Battery.....	122
Mariner I/O Cable Dry End Connector Assembly .....	123
Installation Instructions.....	124
Checking the Wiring .....	125
<b>CHAPTER 5 – TESTING THE WORKHORSE .....</b>	<b>126</b>
Testing the Workhorse II with <i>TRDI Toolz</i> .....	127
Time Set .....	127
Display System Parameters.....	128
Instrument Transformation Matrix .....	128
Pre-deployment Test.....	129
Testing the Sensors .....	129
Beam Continuity.....	130
Dock Side Tests .....	131
Dock Side Diagnostic Test.....	131
Dock Side Peripheral Tests .....	131
Sea Acceptance Tests .....	133
Interference Test.....	134
Interference Test Platform Test Set up.....	134
Interference Test Computer Screen Display Set up .....	134
How to Identify Interference .....	134
Water Profile Range Test .....	135
Water Profile Range Platform Test Set up .....	135
Water Profile Range Computer Screen Display Set up.....	136
How to Determine the Maximum Range of the ADCP .....	136
Ringing Test.....	136
Ringing Test Platform Test Set up .....	137

Ringing Test Computer Screen Display Set up .....	137
How to Determine the Ringing Test Results .....	137
Transducer Alignment Test .....	138
Platform Testing Setup .....	138
Computer Screen Display Setup.....	139
Transducer Alignment Results Sheet .....	140
Water Profile Reasonableness Test.....	140
Water Profile Reasonableness Platform Test Set up .....	140
Water Profile Reasonableness Display Set up.....	141
How to Determine Water Profile Reasonableness .....	141
Bottom Tracking Test .....	141
Bottom Tracking Platform Test Set up .....	142
Bottom Tracking Computer Screen Display Set up .....	142
How to Determine Bottom Tracking Reasonableness .....	142
<b>CHAPTER 6 - TROUBLESHOOTING .....</b>	<b>144</b>
Equipment Required .....	145
Basic Steps in Troubleshooting .....	146
Troubleshooting the WorkHorse.....	146
Troubleshooting Safety .....	146
Troubleshooting a Communication Failure .....	147
Incorrect Wakeup Message .....	147
No Wakeup Message .....	149
Check the Power .....	150
Check the I/O Cable.....	150
Check the Mariner Cables .....	151
ADCP Checks .....	151
Mariner Deckbox Checks.....	152
Troubleshooting a Built-In Test Failure .....	153
When to use the Spare Boards Kit.....	153
Troubleshooting a Beam Failure .....	155
Troubleshooting a Sensor Failure.....	156
Fault Log.....	156
System Overview.....	157
Operating Modes .....	157
Command Mode .....	157
Ping Mode.....	157
<b>CHAPTER 7 - RETURNING SYSTEMS TO TRDI FOR SERVICE .....</b>	<b>158</b>
Shipping the ADCP .....	159
Returning Systems to the TRDI Factory.....	160
Returning Systems to TRDI Europe Factory.....	161
<b>CHAPTER 8 - SPECIFICATIONS .....</b>	<b>164</b>
Outline Installation Drawings.....	171
<b>APPENDIX A - NOTICE OF COMPLIANCE .....</b>	<b>194</b>
Date of Manufacture.....	195
Environmental Friendly Use Period (EFUP) .....	195
WEEE.....	195
CE .....	195
Material Disclosure Table.....	196

## LIST OF FIGURES

Figure 1.	WorkHorse 200- and 6000-meter Monitor ADCPs .....	4
Figure 2.	200- and 6000-meter WorkHorse Sentinel ADCP .....	4
Figure 3.	WorkHorse Mariner ADCP .....	5
Figure 4.	WorkHorse 200- and 6000-meter External Battery Case Overview .....	6
Figure 5.	Deckbox (Front View) .....	7
Figure 6.	Deckbox (Rear View) .....	7
Figure 7.	Deckbox (Top View).....	8
Figure 8.	AC Power Adapter .....	12
Figure 9.	WorkHorse Monitor/Sentinel Connections .....	16
Figure 10.	Mariner Connections.....	17
Figure 11.	Mariner with Trigger Connections.....	18
Figure 12.	Mounting the Instrument with a Clamp Design .....	24
Figure 13.	End-Cap User Mounting Holes .....	24
Figure 14.	Removing the I/O Cable .....	25
Figure 15.	External Battery Pack Connection .....	27
Figure 16.	Do not use Zip-Ties Directly on Cables .....	29
Figure 17.	Cables Protected with Abrasion Resistant Sleeving .....	30
Figure 18.	Typical Mariner Interface Cable Layout (Overview) .....	30
Figure 19.	Monitor and Sentinel I/O Cable Wiring .....	31
Figure 20.	Mariner I/O Cable Wiring .....	32
Figure 21.	Mariner Deckbox to Computer Serial Cable .....	32
Figure 22.	External Battery Pack “Y” Cable .....	33
Figure 23.	RS232-to-RS422 Converter Wiring (25-Pin to 9-Pin) .....	33
Figure 24.	Optional 737-3171-00 Conversion Cable (0.5 meter) Wiring .....	34
Figure 25.	Teledyne RD Instruments Sea Spider Bottom Mount.....	35
Figure 26.	View from the Bottom.....	35
Figure 27.	Trawl Resistant Bottom Mount .....	36
Figure 28.	Deep-Water Mount .....	36
Figure 29.	Buoy Mount with External Battery.....	36
Figure 30.	Subsurface Buoy.....	37
Figure 31.	Buoy Mount.....	37
Figure 32.	Load Cage .....	37
Figure 33.	Over-the-Side Mount .....	38
Figure 34.	Inside Vessel Mounting of a WorkHorse Mariner 300 kHz Transducer.....	40
Figure 35.	Underneath Vessel Mounting of a WorkHorse Mariner 300 kHz Transducer .....	41
Figure 36.	Barnacle Damage to Urethane Face.....	47
Figure 37.	Transducer Misalignment Reference Points.....	49
Figure 38.	Mariner/Monitor Parts Location (200 Meter) .....	56
Figure 39.	Mariner/Monitor Parts Location (500 Meter Systems) .....	57
Figure 40.	Sentinel Parts Location (200 Meter Systems).....	58
Figure 41.	Sentinel Parts Location (500 Meter Systems).....	59
Figure 42.	Sentinel End-cap and Battery Pack Parts Location .....	60
Figure 43.	External Battery Pack Parts Location.....	60
Figure 44.	6000-meter WorkHorse Monitor Parts Location.....	61
Figure 45.	6000-meter WorkHorse Sentinel Parts Location.....	61
Figure 46.	Transducer View.....	63
Figure 47.	End-Cap View .....	63
Figure 48.	High Pressure O-Ring Detail View.....	77
Figure 49.	Purge Plug O-Ring Replacement.....	78
Figure 50.	Workhorse Lithium Battery Pack.....	83
Figure 51.	Compass Calibration.....	87
Figure 52.	Compass Calibration.....	91
Figure 53.	Mariner Adapter Plate.....	93

Figure 54.	Thermistor and Pressure Sensor .....	97
Figure 55.	WorkHorse Pressure Sensor.....	99
Figure 56.	Installing the CompactFlash Card .....	101
Figure 57.	PC Card Recorder .....	101
Figure 58.	Antifouling Paint Applied to a WorkHorse Sentinel .....	106
Figure 59.	Original Workhorse Board Stack .....	110
Figure 60.	Transmit Cable .....	111
Figure 61.	PC Board Connectors.....	111
Figure 62.	Workhorse II Board Stack.....	112
Figure 63.	Ground Jumper.....	112
Figure 64.	Mounting Hardware .....	112
Figure 65.	Modified Dummy Plug.....	116
Figure 66.	Extracting Wrench .....	116
Figure 67.	Lock Nut Removal Socket .....	116
Figure 68.	Removing the Connector.....	117
Figure 69.	End-Cap Connector with Isolation Bushing .....	118
Figure 70.	End-Cap Connector Wiring – WorkHorse ADCP .....	119
Figure 71.	WorkHorse External Battery Case Wiring.....	120
Figure 72.	Lithium Battery Test Points on the CPU Board.....	122
Figure 73.	Lithium Battery.....	122
Figure 74.	Mariner I/O Cable Construction .....	124
Figure 75.	Testing the Navigation Connections.....	132
Figure 76.	Interference Test .....	134
Figure 77.	Transducer Alignment Test .....	139
Figure 78.	Transducer Alignment Display.....	139
Figure 79.	Water Profile Reasonableness Course .....	141

## LIST OF TABLES

Table 1.	Comparison of Workhorse II to the original Workhorse .....	2
Table 2.	WorkHorse Mariner Deckbox Mains Input Power Specification .....	14
Table 3:	Window Thickness.....	43
Table 4:	Wavelength of sound in seawater (1500 m/s sound speed) .....	44
Table 5:	WorkHorse 200 and 500 meters Spare Parts .....	64
Table 6:	High-Pressure Systems Spare Parts.....	65
Table 7.	Replacement Kits.....	66
Table 8:	Dock Side Test Set Up.....	131
Table 9:	Dock Side Peripheral Tests Set up .....	132
Table 10:	Dock Side Peripheral Test Results .....	132
Table 11:	Command Files.....	133
Table 12:	Interference Test Minimum Water Depth Requirement.....	134
Table 13:	Water Profile Range Test Minimum Water Depth .....	135
Table 14:	Water Profile Range Test Platform Speed .....	135
Table 15:	Recommended Blanking Distance .....	137
Table 16:	Ringing Test Water Depth Requirement .....	137
Table 17:	Transducer Alignment Test Water Depth Requirement.....	138
Table 18:	Water Profile Reasonableness Water Depth Requirement .....	140
Table 19:	List of Least Replaceable Assemblies .....	145
Table 20:	Required Test Equipment.....	145
Table 21:	Pre-deployment Test (PA) Possible Cause of Failures .....	154
Table 22:	Broad Bandwidth Water Profiling .....	166
Table 23:	Narrow Bandwidth Water Profiling.....	166
Table 24:	WorkHorse Range .....	167
Table 25:	Bottom Track Profile Parameters .....	167
Table 26:	Bottom Track Velocity (for $ V  < 10$ m/s) .....	167

Table 27:	Profile Parameters.....	167
Table 28:	Echo Intensity Profile .....	168
Table 29:	Standard Sensors – Original WH Electronics .....	168
Table 30:	Standard Sensors – WHII Electronics.....	168
Table 31:	Transducer and Hardware .....	169
Table 32:	Environmental Specifications .....	169
Table 33:	Power .....	170
Table 34:	Lithium Battery Specifications.....	170
Table 35:	Outline Installation Drawings .....	171
Table 36:	Toxic or Hazardous Substances and Elements Contained in Product.....	196

**REVISION HISTORY**

**March 2024**

Changed Velocity Accuracy Table 27, page 167 for 1200 and 600kHz from 0.25% and ±2.5 mm/s to 0.3% and ± 3mm/s.

**February 2024**

- Updated Returning Systems to the TRDI Factory, page 160 Brokerage address.

**October 2023**

- Updated Figure 10
- Updated figure 20 signal names.

**September 2023**

- Updated battery installation procedure. Added photos.

**July 2023**

- Updated website address.

**June 2023**

- Corrected Figure 20.

**May 2023**

- Added warning to not swap individual boards.
- Updated transducer beam color to black.

**April 2023**

- Updated recorder capacity in Table 1 and specifications.

**December 2022**

- Updated EAR footer.
- Updated transducer head color of the 6000-meters systems.

**November 2022**

- Added the Workhorse II electronics: WHII 6000-meter and WH systems sent in for repair that require a CPU, DSP, or PIO board replacement will ship with the WHII electronics and the WH LPMBH 7-pin end-cap connector.
- Added Mariner Trigger function information from FST-016.

#### April 2022

- 95Z-6007-00 replaces the 90Z-8000-00 CD.

#### November 2021

- Removed Gyrocompass Interface – no longer sold.

#### January 2020

- Corrected O-ring size from 2-260 to 2-261 on page 101.

#### July 2019

- Corrected Mariner dry-end connector dimensions on page 27.
- Updated the CF command recommended blank distance.
- Updated outline installation drawing 967-6113 to Rev A.
- Added outline installation drawing 967-6159.
- Updated logo to Teledyne Marine.

#### June 2018

- Replaced setup cards with new Deployment Guides and Getting Started sheets.
- Added using TRDI Toolz software.
- Added Vent Plug information.
- Updated outline installation drawings.
- Added Export Administration Regulations (EAR) footers

#### August 2016

- Added outline drawings 967-9006.

#### March 2016

- Added using the cable clips to the I/O Cable and Dummy Plug section.
- Added the Lithium Battery Pack information from FST-053.
- Updated outline drawings 961-6031, 967-6113 and 967-6114.
- Updated the high-pressure end-cap removal and replacement sections from 6mm bolts to 8mm. Torque specifications were changed to 9.6 Newton-meters (85 pound-inches).
- Added the purge plug to the maintenance chapter.
- Updated the High-Pressure O-Ring Detail View Figure 48, page 77.
- Corrected the [Installing the Spare Board Kit](#) torque specification for the M4 screws holding the PC board stack to the transducer head from 4 Nm to 6 Pound-Force Inch (0.67 Nm).
- Updated the Testing the CPU Lithium Battery Voltage section.

#### March 2014

- Updated the specifications in Table 25 and Table 26, page 167.
- Added the Transducer Alignment Test for Mariner systems to the Sea Acceptance Tests section.
- Corrected the 300 kHz acoustic window thickness recommendation from 0.5” to 3/8” (0.375”) on Table 3, page 43.



- Corrected the bullets under How to Determine the Maximum Range of the ADCP, page 136 from “The bin must have a percent good value above 25%” to “The bin must be > 25% of the sum of 3-beams Solutions (percent good 1) and 4-beams Solutions (percent good 4), [(PG1 + PG4) > 25%]”. Corrected the correlation threshold from 120 counts to 64 counts.
- Updated the script file names in the Installing the Spare Boards Kit section and added instructions for installing the pressure sensor coefficients.

#### February 2013

- Combined Monitor/Sentinel and Mariner User’s Guide into the operation manual.
- Added corrections for ICN 145 I/O Connector Lubricant.
- Added 6000-meter outline installation drawings 967-6113, 967-6114, and 967-6115.
- Updated styles and fonts.
- Updated the maintenance procedures and parts location drawings.
- Updated Commands and Output Data Format guide to 5x.40 firmware.

#### August 2010

- Added corrections for ICNs 082, 100, 113, 116, 118, 120, 126, 127, and 130.
- Added information from FST-021.
- Updated Commands and Output Data Format guide to 5x.38 firmware.

#### November 2007

- Added corrections for the following ICNs: ICN063, RDI Tools Test Results File, ICN064, Corrections to WorkHorse Commands and Output Data Format, ICN065, WorkHorse Specifications, ICN077, Additions to the CP Command.
- Removed Rio Grande (now has its own manual).
- Updated Commands and Output Data Format guide to 16.30 firmware.

## HOW TO CONTACT TELEDYNE RD INSTRUMENTS

If you have technical issues or questions involving a specific application or deployment with your instrument, contact our Field Service group:

### Teledyne RD Instruments

14020 Stowe Drive  
Poway, California 92064

Phone +1 (858) 842-2600

Sales – [rdisales@teledyne.com](mailto:rdisales@teledyne.com)

Field Service – [rdifs@teledyne.com](mailto:rdifs@teledyne.com)

### Teledyne RD Instruments Europe

2A Les Nertieres  
5 Avenue Hector Pintus  
06610 La Gaude, France

Phone +33(0) 492-110-930

Sales – [rdie@teledyne.com](mailto:rdie@teledyne.com)

Field Service – [rdiefs@teledyne.com](mailto:rdiefs@teledyne.com)

Client Services Administration – [rdicsadmin@teledyne.com](mailto:rdicsadmin@teledyne.com)

Web: <https://www.teledynemarine.com>

For all your customer service needs including our emergency 24/7 technical support, call +1 (858) 842-2700

### Self-Service Customer Portal

Use our online customer portal at <https://www.teledynemarine.com/support/RDI/technical-manuals> to download manuals or other Teledyne RDI documentation.

### Teledyne Marine Software Portal

Teledyne RD Instruments Firmware, software, and Field Service Bulletins can be accessed only via our Teledyne Marine software portal.

To register, please go to <https://tm-portal.force.com/TMsoftwareportal> to set up your customer support account. After your account is approved, you will receive an e-mail with a link to set up your log in credentials to access the portal (this can take up to 24 hours).

Once you have secured an account, use the Teledyne Marine software portal to access this data with your unique username and password.

If you have an urgent need, please call our Technical Support hotline at +1-858-842-2700.

## CONVENTIONS USED IN THIS MANUAL

Conventions used in the WorkHorse Acoustic Doppler Current Profiler (ADCP) Operation Manual have been established to help learn how to use the system quickly and easily.

Menu items are printed in bold: click **Collect Data**. Items that need to be typed by the user or keys to press will be shown as <F1>. If a key combination were joined with a plus sign (<ALT+F>), press and hold the first key while pressing the second key. Words printed in italics include program names (*TRDI Toolz*) and file names (*TestWH.txt*).

Code or sample files are printed using a fixed font. Here is an example:

```
[BREAK Wakeup A]
WorkHorse Broadband ADCP Version 50.40
Teledyne RD Instruments (c) 1996-2012
All Rights Reserved.
>
```

You will find three other visual aids that help you: Notes, Cautions, and References.



This paragraph format indicates additional information that may help you avoid problems or that should be considered in using the described features.



This paragraph format warns the reader of hazardous procedures (for example, activities that may cause loss of data or damage to the WorkHorse ADCP).



This paragraph format tells the reader where they may find additional information.

NOTES

# Chapter 1

## AT A GLANCE



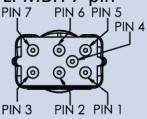
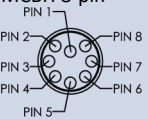
In this chapter, you will learn:

- WorkHorse Models and Options
- System Overview
- Computer Considerations
- Power Overview
- Setting up the ADCP
- Caring for your Workhorse System

# Workhorse and Workhorse II

This manual covers the original Workhorse (WH) system, Workhorse II (WHII) 6000-meter, and WH systems sent in for repair that requires a board stack replacement. Repaired systems will ship with the WHII electronics and the WH LPMBH 7-pin end-cap connector.

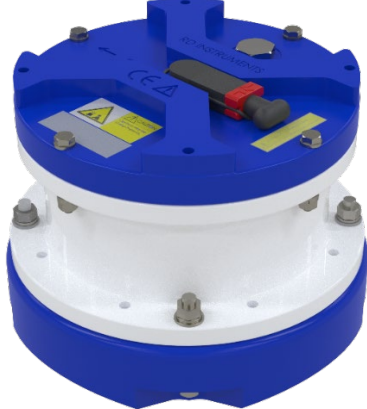
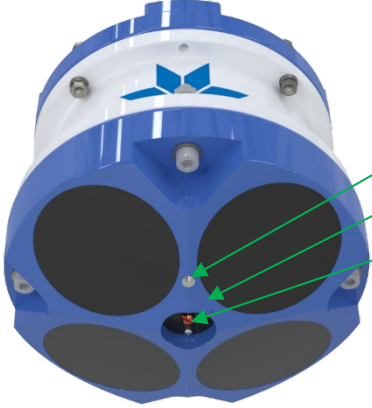
**Table 1. Comparison of Workhorse II to the original Workhorse**

	WorkHorse	WorkHorse II	Notes
Connector Type	LPMBH 7-pin 	MCBH 8-pin  or LPMBH 7-pin	MCBH 8-pin improved strain relief and protection of the connector and cable.  LPMBH 7-pin maintains compatibility to user's underwater cables.
Memory	PCMCIA, 4 GB max	Compact Flash, with the maximum memory capacity not to exceed 4GB per deployment.	Use the <b>RE ErAsE</b> command to erase and format the WHII CompactFlash memory card.
LADCP WM15 Surface Tracking WM15 High-res WM11 High-speed sampling WM12	Purchased options	Standard	See the WorkHorse Operation Manual, Chapter 4 for help on installing feature upgrades.
Compass Type Compass Accuracy / Resolution / Max Tilt	Flux Gate Compass $\pm 2^\circ$ @ $60^\circ$ magnetic dip angle, 0.01°, $\pm 15^\circ$	ISM Compass 1°RMS, 0.1°, $\pm 70^\circ$	The WH uses the Compass Commands to calibrate the Flux Gate compass.  Use the <i>ISM Compass Calibration</i> software to calibrate a WHII compass.
Pressure Sensor / Short-term uncertainty Max. drift	Optional $\pm 0.1\%$ $\pm 0.25\%$	Standard $\pm 0.1\%$ $\pm 0.25\%$	Standard 20 Bar pressure sensor included, or 600 BAR (optional).
Raw Field Strength Recorded	NA	Firmware enabled	Use <i>Compass Post Calibration</i> software to correct for heading errors due to hard and soft iron effects in the Workhorse reference frame during the deployment.
Software	PlanADCP, WinADCP	Workhorse II Plan, ISM Compass Calibration, Compass Post Calibration, WinADCP	Use the <i>PlanADCP</i> software to create a deployment command file if the system has the original Workhorse electronics installed  Use the <i>Workhorse II Plan</i> software to create a deployment command file for systems with Workhorse II electronics installed.



## System Overview

The ADCP transducer assembly contains the end-cap, housing, transducer ceramics, and electronics. The standard acoustic frequencies are 1200, 600, and 300 kHz. See the [Outline Installation Drawings](#) for dimensions and weights.

Picture	Description
	<p>The Input/Output (I/O) cable connects the WorkHorse ADCP to the computer and external power supply. When the cable is not connected, use the dummy plug to protect the connector.</p> <p>The end-cap holds the I/O cable connector. Use the Cable Clip and O-Ring to hold the cable onto the connector.</p> <p>When assembling the unit, match the Beam 3 mark on the end-cap with beam 3 number on the transducer.</p> <p>Use the Vent Plug to vent the system before opening the housing. Loosen the port ½ turn and listen for airflow; if none, then open another ½ turn and listen again for airflow. Repeat until the Vent Plug is fully removed. This will ensure no internal pressure is present when removing the housing.</p>
	<p>The black urethane faces cover the transducer ceramics. Never set the transducer on a hard surface. The urethane faces may be damaged.</p> <p>The standard WorkHorse white plastic housing allows deployment depths to 200 meters.</p> <p>The Thermistor measures the water temperature.</p> <p>The Beam-3 mark shows the location of Beam-3 (Forward).</p> <p>The pressure sensor (standard 200 Bar) measures water pressure (depth).</p> <p>The WorkHorse electronics and transducer ceramics are mounted to the transducer head. The numbers embossed on the edge of the transducer indicate the beam number. When assembling the unit, match the transducer beam number 3 with the Beam 3 mark on the end-cap.</p>
	<p>The Sentinel ADCP includes a longer housing to hold an alkaline battery. The internal battery pack has 450 watt-hours (Wh) of usable energy at 0 C. When fresh, the voltage is +42 VDC. When depleted, the voltage drops to 30 VDC or less.</p> <p>WHII electronics include one Compact Flash card, with the total memory capacity not to exceed 4GB per deployment.</p> <p>WH Sentinel electronics include one PCMCIA memory card. Two PCMCIA memory cards slots are available. The maximum memory for each slot is 2GB, with the total memory capacity not to exceed 4GB. Please note that PCMCIA cards are no longer available.</p>

## WorkHorse Models and Options

The following section explains the different models and options available for WorkHorse ADCPs.

### WorkHorse Monitor

The WorkHorse Monitor is designed to measure real-time current profiles from temporary or permanent mounting in the ocean, near-shore, harbors, and lakes. The Monitor ADCP system consists of an ADCP, cables, RS-232-to-RS-422 converter, CompactFlash memory card, and software. The Monitor system requires the addition of a Windows® compatible computer to collect data.



**Figure 1.** WorkHorse 200- and 6000-meter Monitor ADCPs

### WorkHorse Sentinel

The WorkHorse Sentinel is designed for several-month autonomous current profile deployment from temporary or permanent mounting in the ocean, near-shore, harbors, and lakes. The Sentinel ADCP system consists of an ADCP, cables, battery pack, CompactFlash memory card, and software. Battery capacity can be increased with upgrades for longer deployments. The Sentinel can also be used for direct-reading current profile operation. The Sentinel system requires the addition of a Windows® compatible computer to configure the ADCP and replay collected data.



**Figure 2.** 200- and 6000-meter WorkHorse Sentinel ADCP

## WorkHorse Mariner

The WorkHorse Mariner is designed to measure real-time current profiles from temporary or permanent mounting in a vessel. The Mariner ADCP system consists of a Monitor ADCP with Bottom Track mode, cables, Deckbox, Mounting Plate, CompactFlash memory card, and software.

The Deckbox converts AC power input or 12 VDC input into 48 VDC output for the Mariner input power. It can convert the computer serial interface from RS232 to RS422. The Mariner system requires the addition of a Windows® compatible computer to collect data.



Figure 3. WorkHorse Mariner ADCP

## WorkHorse Options

- **Bottom Track** – You can use your WorkHorse ADCP from moving boats and ships with the Bottom Track Upgrade. Once the Bottom Track Upgrade is added, a WorkHorse ADCP can measure both water depth and boat velocity over the ground.
- **Shallow Water Bottom Track Mode 7** – You can use your WorkHorse 1200 kHz ZedHed™ ADCP in water as shallow as 30cm. This feature is included in WHII systems.
- **High-Resolution Water Profiling Modes** – This upgrade allows you to collect water profiles using Water Modes 1, 5, 8, and 11. Modes 1 and 11 are included in WHII systems.
- **High Ping Rate Water Mode** – This upgrade allows you to collect water profiles using Water Mode 12. This feature is included in WHII systems.
- **Waves** – This upgrade allows you to use the ADCP as a wave gauge.
- **VmDas Software** – Controls the ADCP and displays profile data through a personal computer.
- **WinRiver II Software** – Controls the ADCP and displays discharge data and profile data through a personal computer.
- **Waves Software** – Controls the ADCP and displays waves data through a personal computer.
- **Memory** – The WorkHorse Sentinel ADCP includes one memory card. Two PCMCIA memory card slots are available for all WorkHorse ADCPs (see [PC Card Recorder](#) for memory card specifications). The maximum memory for each slot is 2GB, with the total memory capacity not to exceed 4GB. **Please note that PCMCIA cards are no longer available.** WHII systems include one Compact Flash card with the maximum memory capacity not to exceed 4GB per deployment.
- **Spare boards kit** – Contains a complete set of spare printed circuit boards for a WorkHorse ADCP. The set does not include the receiver board (not field replaceable).
- **High-Pressure Housing** – The standard WorkHorse housing allows deployment depths to 200 meters. High-pressure housings are available with depth rating of 500 and 6000 meters. See the [Outline Installation Drawings](#) for dimensions and weights.

- **External Battery** – Adding external batteries can increase the deployment length for Sentinel ADCPs. Use an External Battery with a Monitor ADCP to provide backup power or for self-contained deployments.



**Figure 4. WorkHorse 200- and 6000-meter External Battery Case Overview**

- **Lithium Battery Pack** – The optional Workhorse Lithium Battery Packs can be used interchangeably in Workhorse Sentinels, Workhorse Long Rangers, and Workhorse Quartermasters. This battery pack is assembled using lithium battery cells that provide 34 VDC with a capacity of approximately 1650 Wh. The battery includes a safety circuit that protects the battery and users against short circuits and provides users the ability to test the pack. The circuit also turns the battery off at its end of life before the battery fully discharges. This happens when about 97% of the battery's capacity is depleted.

#### Mariner Options

- **Mounting Plate** – A bronze plate that helps mount the transducer head to a vessel. See the [Outline Installation Drawings](#) for dimensions.

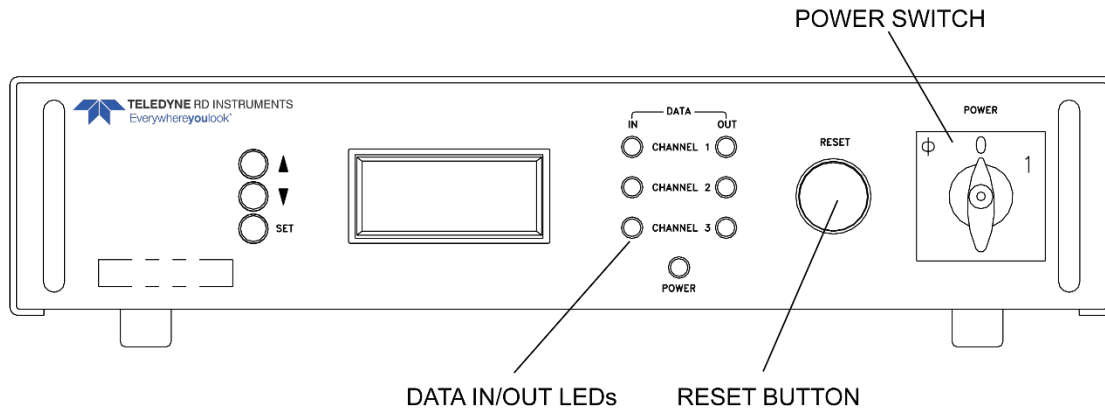
# Mariner Deckbox Overview

The Deckbox contains all interfaces to/from the ADCP, computer/terminal, and power.

**Power Switch** – The power switch is a combination switch/circuit breaker. The **Power Status** LED next to the circuit breaker lights when power is applied to the Deckbox.

**Reset Button** – Pushing the **Reset** button sends a break to the ADCP.

**Data In/Out LEDs** – **Channel 1 In** indicates data transmission from the computer to the ADCP. **Channel 1 Out** indicates data transmission from the ADCP to the computer.



**Figure 5. Deckbox (Front View)**

**ADCP (J17)** – Connects the ADCP to the Deckbox.

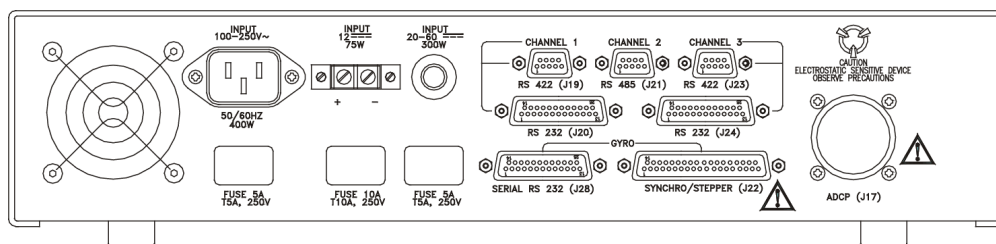
**Channel 1 RS 422 (J19)** – Connects the computer’s RS-422 port to the Deckbox. Use this only if your computer has a RS422 serial port. If your computer has a RS-232 serial port (standard), use J20.

**Channel 1 RS 232 (J20)** – Connects the computer RS-232 port to the Deckbox.

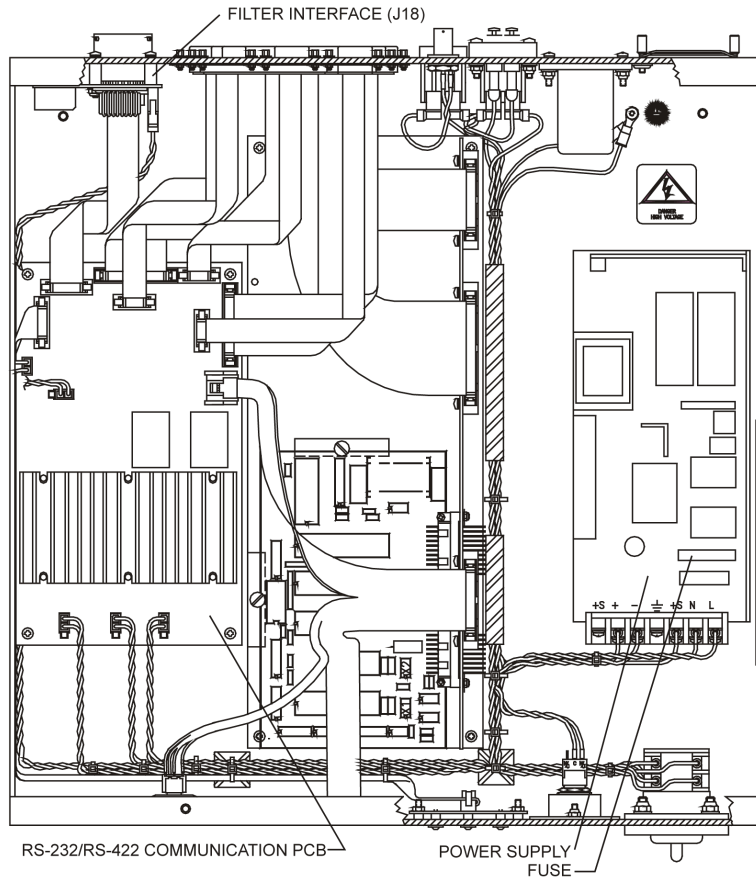
**AC Power Input** – The Deckbox accepts input voltages of 98-264 VAC, 50-60Hz (J27). This input voltage will be converted to 48 VDC. This is the voltage supplied to the ADCP.

**DC 12-Volt Input** – Use a 12 VDC car battery (J26) when AC power is not available. The Deckbox converts the voltage to 48 VDC. This is the voltage supplied to the ADCP. Use the largest rated amp-hour battery as possible. A car battery should last one to two days powering a 1200 kHz ADCP.

**DC 20 to 50 Volt Input** – If you are using an external DC power supply connected to the Deckbox on J25 (20 to 50 VDC, 3.0 A), the voltage from the external power supply is sent *directly* to the ADCP. This is useful if you want to increase (higher voltage level) or decrease (lower voltage level) the range of the ADCP. The current requirement for the power supply is listed as a reference. Using a lesser-rated power supply can cause the voltage level to drop. The ADCP will draw only the current it needs.



**Figure 6. Deckbox (Rear View)**



**Figure 7. Deekbox (Top View)**



## Mariner Triggering Function

In some applications, it is advantageous to have the ability to trigger the transmit cycle of the WorkHorse Mariner ADCP. Triggering the WorkHorse Mariner ADCP allows you to synchronize the time when it transmits with other devices to avoid interference between the acoustic instruments.

The standard WorkHorse Mariner Deckbox is designed to work with a WorkHorse Mariner ADCP down long cables using RS-422 communications. If triggering is desired, then the WorkHorse Mariner Deckbox must be modified from its standard RS-422 communications link to the Mariner ADCP to a RS-232 communications link.



This modification must be done (or ordered for new systems) at Teledyne RD Instruments factory and requires the return of the WorkHorse Mariner Deckbox and the WorkHorse Mariner ADCP.

Please contact your local sales representative if you are interested in modifying your system for this feature.



All communications and other functions described in the WorkHorse Operation Manual and Mariner Deployment Guide are correct and apply to the Mariner system.

## Using the Modified Deckbox with Trigger

The following procedure assumes you have a modified WorkHorse Mariner Deckbox, and the Mariner ADCP is set to RS-232 communications. The front of your Mariner Deckbox will be clearly marked indicating that it has Trigger.

### Communication Setup

The standard communications setup to the WorkHorse Mariner Deckbox with Trigger remains the same as with a standard WorkHorse Mariner Deckbox. The only difference is that the WorkHorse Mariner Deckbox with Trigger has been permanently changed to only pass-through RS-232 communications down to the ADCP. As a result of this modification, the WorkHorse Mariner ADCP must be set to RS-232 communications. This setting is controlled via a switch inside the ADCP and will have been set by TRDI during the modification of your Deckbox if ordered for a new system.



See [Changing Communications Setting](#) for more information.

Communications to the WorkHorse Mariner ADCP is through the RS-232 25-pin connector J20 on the back of the Deckbox. Connect the computer to this connector to establish communications to the Mariner ADCP.



For reliable communications, the RS-232 cable to Deckbox must be less than 25-meters length and the J17 cable to the Mariner must be no longer than 25-meters.

## Baud Rate Setup Considerations

The default baud rate of the WorkHorse Mariner is 9600. The maximum baud rate possible when using the WorkHorse Mariner Deckbox with Trigger is 38400. Triggering only works with a baud-rate less than 38400.

## Trigger Signals, Breaks, and Commands

The Mariner ADCP Deckbox can only be set up in slave mode (receiving trigger signals from other instruments). The setup is controlled through the Ping Synchronization Commands (**SA**, **SM**, **ST**, and **SW**). The default setup for the Workhorse Mariner is for triggering to be disabled (**SM0**). The **SB** command must be set to **SB0** to use the Master/Slave setup.

To avoid a trigger-signal being handled as a hardware-break, the **SB0** command needs to be set.

### To set the SB command to SB0:

1. Send **SB0**.
2. Immediately following the **SB0** command, send a **Break**.
3. The **SB0** command is now in effect and the ADCP will ignore potential <Breaks> on the Channel B RS-422 lines.



Once the SB0 command is set, it will not be reset by a CR1 command (SB1 is the default setting).

4. To enable the triggering in the slave mode, add the following commands to the command file used for the Workhorse Mariner.

```
SM2
ST0
WP1
TE00:00:00.00
TP000000
```

## Injecting a Trigger Signal

The access to the trigger is via the DB9 connector labeled J21 RS485 on the back of the Deckbox. Pin 6 is (+) and pin 5 is (GND). The input trigger pulse must be a TTL pulse between 15mSec to 38mSec.



The WorkHorse Mariner only allows a Trigger In signal.

## Verify Triggering on The Bench

Before installing the system in the field, verify it on the bench.

1. Connect the Workhorse Mariner to the Mariner Deckbox.
2. Apply power to the Mariner Deckbox.
3. Connect a serial cable from the Deckbox to a PC and open *TRDI Toolz*.
4. Use a frequency generator to generate a TTL pulse width of 20mSec every second.
5. In *TRDI Toolz* send following commands:

```
CR1
WP1
TE00:00:00.00
TP000000
SM2
ST0
CK
CS
```

The Mariner should now ping every second.

# Computer Considerations

TRDI designed the Workhorse II ADCP to use a Windows® compatible computer. The computer controls the ADCP and displays its data, usually through our *WinADCP*, *VmDas*, or *WinRiver II* programs. For testing, TRDI provides *TRDI Toolz* and for system configuration for deployments, use *PlanADCP* for WH systems and *Workhorse II Plan* for WHII systems.



TRDI highly recommends downloading and install all the critical updates, recommended updates, and the service releases for the version of Windows® that you are using prior to installing any TRDI software.

## Minimum Computer Hardware Requirements:

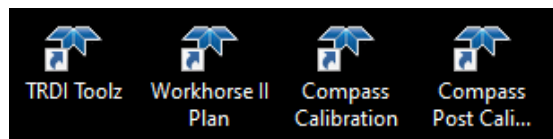
- Windows 10®, Windows 8®, Windows 7® Desktop, Laptop, or Netbook computer
- Screen resolution above 1024x768
- One Serial Port (two or more High Speed UART Serial Port recommended)



*VmDas* has special requirements – see the *VmDas User's Guide* for detailed information on system requirements.

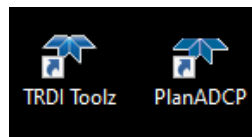
## Workhorse II Software

The Workhorse II requires *TRDI Toolz*, *Workhorse II Plan*, *ISM Compass Calibration*, and *Compass Post Calibration* software.



## Workhorse Software

The Workhorse requires *TRDI Toolz* and *PlanADCP* software.



## To download the software:

1. Use the Teledyne Marine software portal <https://tm-portal.force.com/TMsoftwareportal> to access the software.
2. Download the *TRDI Toolz*, *Workhorse II Plan*, *ISM Compass Calibration*, and *Compass Post Calibration* software.
3. Unzip the files and install by double-clicking on the exe files.

# Power Overview

WorkHorse Monitor, Sentinel, and Mariner ADCPs require +20 to 50 VDC to operate.

## Monitor/Sentinel Power Considerations

The AC Adapter runs on any standard AC power and supplies +48 VDC to run the WorkHorse when the batteries are not connected. The Sentinel's internal battery supplies +42 VDC.



The AC Adapter input voltage is sufficient to override the internal battery voltage (i.e. the ADCP will draw all power from the AC adapter even if the battery is installed and connected).

Transmitted power increases or decreases depending on the input voltage (within the voltage range of 20 to 50 VDC). A fresh battery provides +42 VDC. Batteries spend most of their life at a nominal voltage of +33 VDC.



The transmitted power is decreased approximately 1 DB if the input voltage drops from 42 VDC to 33 VDC. For a 300 kHz WorkHorse ADCP, each DB will result in a decrease in range of one default depth cell.

### Power on Cycle

The power supply must be able to handle the inrush current as well. Inrush current is the current required to fully charge up the capacitors when power is applied to the ADCP. The capacitors provide a store of energy for use during transmit. The inrush current is as high as 3 Amps rms. The ADCP will draw this amperage until its capacitors are fully charged.

*If the power supply limits the current or the power drop on the cable is significant, then the power on cycle will take longer.* It can take up to one minute. You do not want the power to shut down during the inrush current draw, as this may not allow the ADCP electronics to start.

### AC Power Adapter

The AC power adapter is designed to maintain a 400-ma supply under the ADCP's inrush current. The adapters are 75-Watt supplies, with 48 VDC, 1.5 amp outputs. They will not fall back to 0 amps, 0 volts under a load. Customer provided power supplies might shut themselves down under such a load; when that occurs, the ADCP will not wakeup.

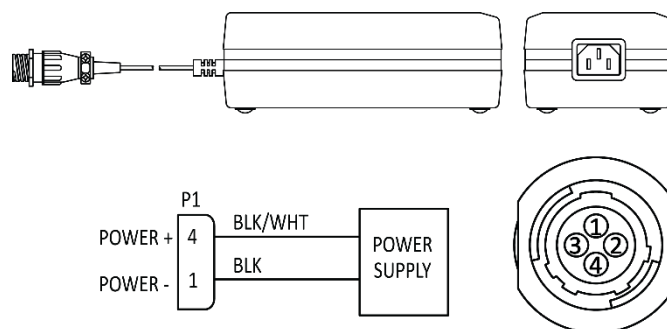


Figure 8. AC Power Adapter

## Sentinel Internal Battery Power Overview

The WorkHorse Sentinel's internal battery supplies +42 VDC. The AC Adapter runs on any standard AC power and supplies +48 VDC to run the WorkHorse Sentinel when the batteries are not connected.



The AC Adapter input voltage is sufficient to override the internal battery voltage (for example, the ADCP will draw all power from the AC adapter even if the battery is installed and connected). Always use the AC adapter when testing the ADCP to conserve the battery power.

Keep in mind the following about Sentinel battery packs:

- TRDI specifies its battery packs to have 450 Watt-hours (Wh) of usable energy at 0°C.
- A Standard WorkHorse battery packs hold 28 'D-cell' alkaline batteries with a voltage, when new, of approximately 42 VDC.
- When the capacity of a battery pack is 50% used, the voltage (measured across the battery connector) falls to approximately 32 to 35 volts. However, keep in mind that this voltage is not an accurate predictor of remaining capacity.
- Transmitted power increases or decreases depending on the input voltage (within the voltage range of 20 to 50 VDC). A fresh battery provides +42 VDC. Batteries spend most of their life at a nominal voltage of +33 VDC.



The transmitted power is decreased one DB if the input voltage drops from 42 VDC to 33 VDC. For a 600 kHz WorkHorse ADCP, each one DB drop will result in a decrease in range of one default depth cell.

- Batteries should be replaced when the voltage falls below 30 VDC (measured across the battery connector).
- Battery packs differ from one to another.
- Store batteries in a cool dry location (0 to 21 degrees C).
- Do not store batteries inside the ADCP for extended periods. The batteries may leak.
- Use batteries within one year of the manufacture date (use by warning date\*).



Do not deploy the system with batteries that are older than the Warning date. It should be noted, that while a battery pack will not be dead after the Warning Date, the actual performance of the battery is in doubt, and TRDI does not warranty any deployment started with a battery pack that is past its Warning date.

TRDI batteries have four dates on them:

**Manufacture Date** is the date the battery was built and final tested.

**TRDI Ship by Date** provides the maximum duration that the battery will remain on our shelves before we will ship and is 6 months after our manufacture date.

**Warning Date\*** provides the last date when the battery should be used to start a deployment and is 12 months from the manufacture date.

**Expiration Date** provides the date when the battery should no longer be considered useful and is 2 years from the manufacture date.

\*A battery pack used to start a deployment prior to the Warning Date means that it will perform as expected and provide the required power for any deployment that was created using the TRDI planning module. For example, if your deployment is going to be 12 months long and the battery label shows it is nine months old, it is safe to use the battery.



Battery replacement induces both single and double cycle compass errors. The compass should be calibrated after replacing the battery pack.

These compass effects can be avoided by using an optional external battery pack. The optional external battery housing holds two batteries, and can easily be replaced on-site. If the optional external battery is placed a minimum of 30 cm away from the ADCP, no compass calibration will be required.

## Optional Lithium Battery Pack

The optional Workhorse Lithium Battery Packs can be used interchangeably in Workhorse Sentinels and the external battery case. This battery pack is assembled using lithium battery cells that provide 34 VDC with a capacity of approximately 1650 Wh. The battery includes a safety circuit that protects the battery and users against short circuits and provides users the ability to test the pack. The circuit also turns the battery off at its end of life before the battery fully discharges. This happens when about 97% of the battery's capacity is depleted (see [Workhorse Lithium Battery Packs](#)).

## Mariner Power Overview

The Mariner Deckbox automatically scales the input voltage to the proper level. No special jumpers or switch settings are required to select the input voltage. If more than one power source is connected to the Deckbox, the highest voltage source will be used. Although this is not recommended, it will not damage the Deckbox.

**AC Power.** The Deckbox accepts input voltages of 90-264 VAC, 47-63 Hz (J27). This input voltage will be converted to 48 VDC. This is the voltage supplied to the ADCP.

**Table 2. WorkHorse Mariner Deckbox Mains Input Power Specification**

Parameter	Value Typical	Units
Input Voltage Range (typical):	90 – 132 180 – 264	Vac @ auto-ranging, low range Vac @ auto-ranging, high range
Line Frequency (typical):	47 – 63	Hz
Inrush Current (typical):	23 47	A @ 115 Vac @ peak line A @ 230 Vac @ peak line
*Input Power (max):	80 380	W @ during awake or asleep W @ during transmit
Ride Through Time (min):	5 40	ms @ 90/180 Vac low line ms @ 90/180 Vac nominal line

\*The 80 and 380 watts are maximum specifications. These have been derived from the maximum power supply rating and the specified minimum efficiency. Actual maximum input power may be lower than the one specified.

**12 VDC Car Battery.** Use a 12 VDC car battery (J26) when AC power is not available. The Deckbox converts the voltage to 48 VDC. This is the voltage supplied to the ADCP. Use the largest rated amp-hour battery as possible. A car battery should last one to two days powering a 1200 kHz ADCP.

**DC Power Supply.** If you are using an external DC power supply connected to the Deckbox on J25 (20 to 50 VDC, 3.0 A), the voltage from the external power supply is sent *directly* to the ADCP. This is useful if you want to increase (higher voltage level) or decrease (lower voltage level) the range of the ADCP. The current requirement for the power supply is listed as a reference. Using a lesser-rated power supply can cause the voltage level to drop. The ADCP will draw only the current it needs.



Transmitted power increases or decreases depending on the input voltage. Higher voltage to the ADCP (within the voltage range of 20 to 50 VDC) will increase the transmitted power. The transmitted power is increased 6 DB if you double the input voltage from 24 VDC to 48 VDC. For a 300 kHz WorkHorse ADCP, each additional DB will result in an increase in range of one default depth cell.



**ADCP Internal Batteries.** If you want the ADCP to use internal battery power (Sentinel Workhorse ADCP or external battery pack) rather than the Deckbox power:

4. Turn OFF or disconnect all power to all ADCP system equipment.
5. Remove the screws on the top cover of the Deckbox. Lift the cover off.
6. Locate the Filter Interface board (see Figure 7). Locate connector J18 and disconnect the twisted black and white cable plugged into this connector. The power from the Deckbox to the ADCP has now been disabled. Only the batteries are powering the ADCP.

## Setting up the WorkHorse System

Use this section to connect the ADCP to a computer and establish communications. Install *TRDI Toolz* and *PlanADCP* (WH system) or *Workhorse II Plan* (WHII systems) software to communicate with the ADCP.

### Set Up the Monitor/Sentinel ADCP

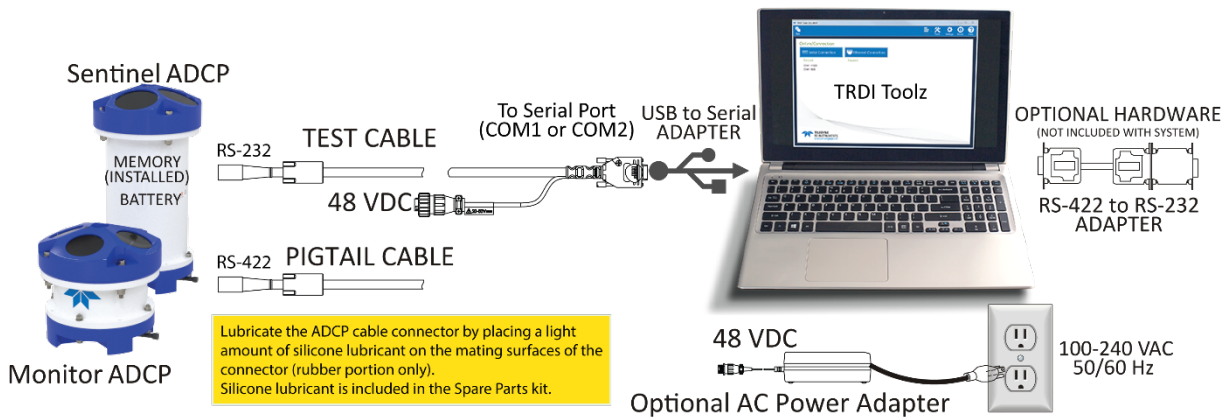
To set up the WorkHorse ADCP:

1. Lubricate the cable connector and connect to the ADCP. Do so by pushing straight in against the connector. Roll the retaining strap over the connector.
2. Attach the I/O cable to your computer's communication port or connect the USB adapter to a spare USB port.



If there is an available internet connection, Windows 10/11 will install the USB driver on first connection. If necessary, install the Virtual COM port (VCP) driver to make the USB adapter appear as an additional COM port. The free FTDI driver download page is available here: <https://ftdichip.com/drivers/>

- Use a RS-422 to RS-232 converter if the ADCP is configured as RS-422.
  - The default factory set communications settings for Sentinel is RS-232, 9600-baud, no parity, 8 data bits and 1 stop bit. Monitor systems default factory set use RS-422, 9600-baud, no parity, 8 data bits and 1 stop bit.
3. Connect +48VDC power to the cable.



**Figure 9. WorkHorse Monitor/Sentinel Connections**




WorkHorse Sentinel batteries are shipped inside the WorkHorse ADCP but **not connected**. Connect the battery and seal the WorkHorse ADCP before deployment.

For testing, the battery can be disconnected to save battery power. If the battery is connected, use the AC power adapter to override the battery voltage to conserve the battery.

# Set Up the Marnier ADCP

## To set up the WorkHorse Mariner ADCP:

1. Connect the I/O cable (J17) from the Deckbox to the WorkHorse ADCP.



Use light amounts of silicone lubricant (included in the spare parts kit) on both the rubber portion of the male pins and female socket to help seat the ADCP cable connectors. Wipe off excessive silicone from the metal portions of the pins. **Regular lubrication is required: Apply silicone lubricant prior to each connection.** See [I/O Cable](#) and [Dummy Plug](#) for details.

2. Attach the serial cable from the Deckbox (J20) for RS-232 or (J19) for RS-422 to your computer's communication port.
  - Use RS-232 (J20) when the serial cable to Deckbox is less than 25-meter length.
  - Use RS-422 (J19) when the serial cable to Deckbox is greater than 25-meter length. Use a RS-232-to-RS-422 converter if your computer only has a RS-232 COM port.
3. Connect power to the Deckbox.

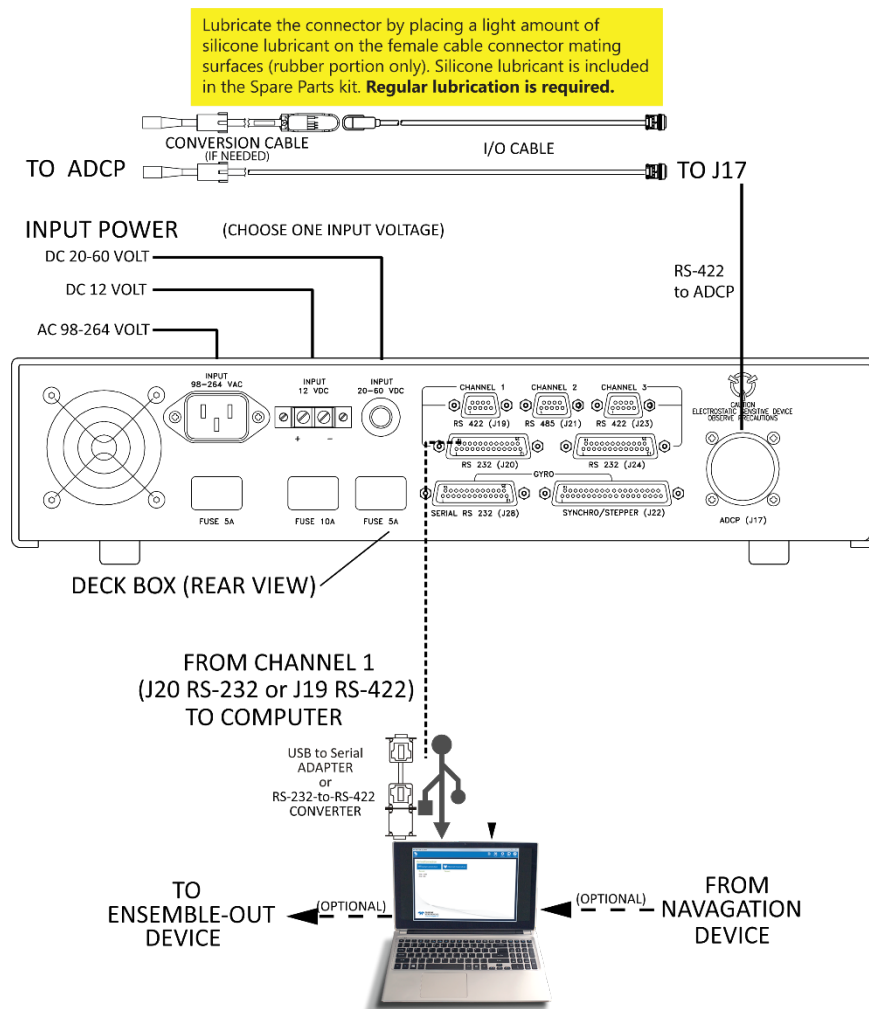


Figure 10. Mariner Connections

# Set Up the Mariner ADCP with Trigger In



This requires the WorkHorse Mariner Deckbox with Trigger and the WorkHorse Mariner ADCP communication setting set to RS-232. See [Mariner Triggering Function](#).

## To set up the WorkHorse Mariner ADCP:

1. Connect the I/O cable to (J17) from the Deckbox to the WorkHorse ADCP.



Use light amounts of silicone lubricant (included in the spare parts kit) on both the rubber portion of the male pins and female socket to help seat the cable ADCP connectors. Wipe off excessive silicone from the metal portions of the pins. **Regular lubrication is required: Apply silicone lubricant prior to each connection.** See [I/O Cable and Dummy Plug](#) for details.

2. Attach the serial cable from the Deckbox (J20) to your computer's communication port. The standard communications settings are RS-232, 9600-baud, no parity, 8 data bits and 1 stop bit.
3. Connect the Trigger In cable to (J21) on the back of the Deckbox. Pin 6 is (+) and pin 5 is (GND). The input trigger pulse must be a TTL pulse between 15mSec to 38mSec.
4. Connect power to the Deckbox.

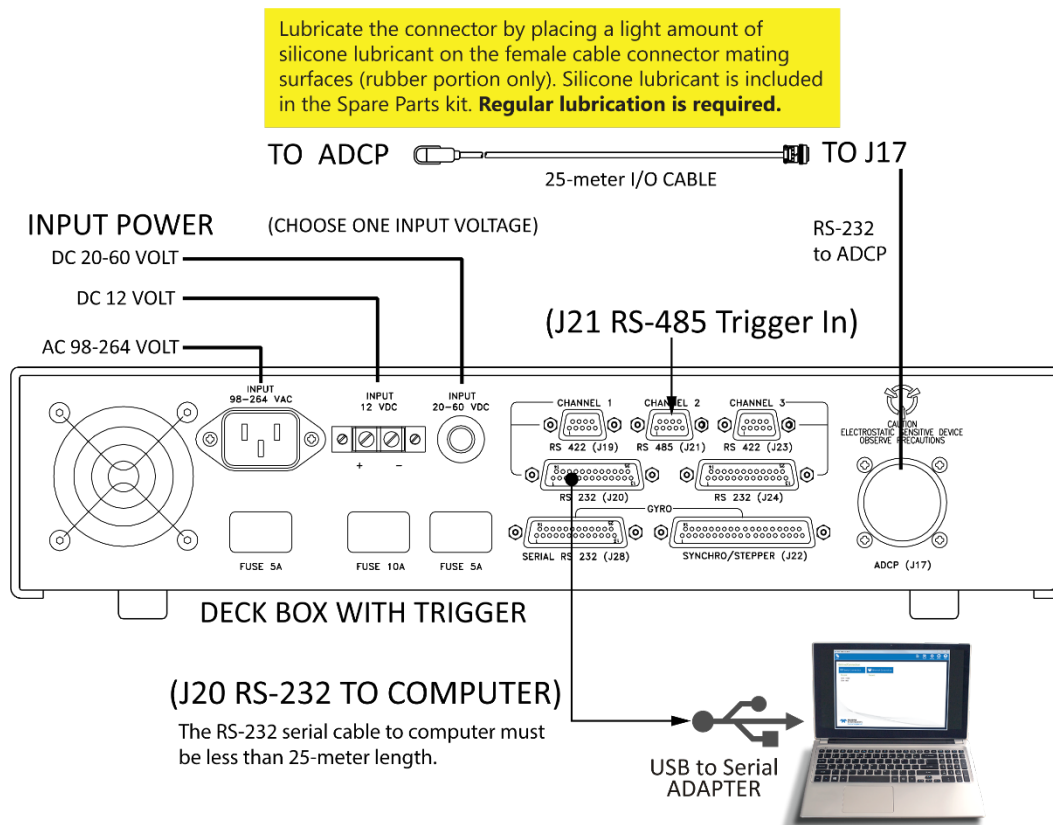
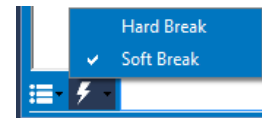
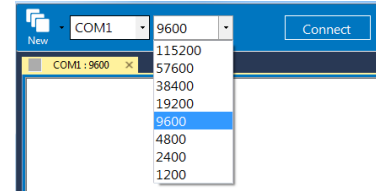


Figure 11. Mariner with Trigger Connections

# Connecting to the System using TRDI Toolz

To establish communications with the WorkHorse:

1. Connect the system and apply power.
2. Start the *TRDI Toolz* software.
3. Select **New Serial Connection**.
4. Enter the ADCP's communication settings. Select the **COM Port** the serial cable is connected to and set the **Baud Rate** from the drop-down lists.
5. Click the **Connect** button. Once connected, the button will change to **Disconnect**.
6. Click the **Break** (⚡) button. From the **Break** button drop down menu, select **Soft Break** (= = =). The wakeup banner will display in the terminal window.



## How do I know if I have a WH or WHII?

```
[BREAK Wakeup A]
Workhorse II Broadband ADCP Version 7x.xx
Teledyne RD Instruments (c) 1996-2022
All Rights Reserved.
>
```

The system has the Workhorse II electronics installed. Use the *Workhorse II Plan* software to create a deployment command file.

```
[BREAK Wakeup A]
WorkHorse Broadband ADCP Version 5x.xx
Teledyne RD Instruments (c) 1996-2010
All Rights Reserved.
>
```

The system has the original Workhorse electronics installed. Use the *PlanADCP* software to create a deployment command file.



If you are unsure of the ADCP's baud rate, use **Tools, Find ADCP**. *TRDI Toolz* will try different baud rates until it connects to the ADCP.

```
>{i7φ²nll²z²jñ~ªñδgJ Checking 9600 baud rate
Checking 115200 baud rate
==
WorkHorse II Broadband ADCP Version 7x.xx
Teledyne RD Instruments (c) 1996-2022
All Rights Reserved.
>
```




For help on using *TRDI Toolz*, click the  icon.




If you don't know what com port(s) were added when using a USB to serial adapter, use *Windows Device Manager*® to determine the Com port. Remove the adapter, wait a moment, note the list of ports, reinsert the adapter and note the new port.


## Changing the Baud Rate in the ADCPs

The ADCP can be set to communicate at baud rates from 300 to 115200. The factory default baud rate is always 9600 baud. The baud rate is controlled via the CB-command. The following procedure explains how to set the baud rate and save it in the ADCP. This procedure assumes that you will be using the program *TRDI Toolz* that is supplied by Teledyne RD Instruments.

<pre>[BREAK Wakeup A] WorkHorse Broadband ADCP Version 50.xx Teledyne RD Instruments (c) 1996-2010 All Rights Reserved. &gt;cr1 [Parameters set to FACTORY defaults] &gt;  Or  [BREAK Wakeup A] Workhorse II Broadband ADCP Version 7x.xx Teledyne RD Instruments (c) 1996-2021 All Rights Reserved. &gt;cr1 [Parameters set to FACTORY defaults] &gt;</pre>	<p>Connect the ADCP to the computer and apply power.</p> <p>Start <i>TRDI Toolz</i> and establish communications with the ADCP.</p> <p>Click the <b>Break</b>  button.</p> <p>At the "&gt;" prompt in the communication window, type <b>CR1</b> then press the Enter key. This will set the ADCP to the factory default settings.</p>
--	--

BAUD RATE	CB-command
300	CB011
1200	CB111
2400	CB211
4800	CB311
9600	CB411 (Default)
19200	CB511
38400	CB611
57600	CB711
115200	CB811

<p>Send the CB-command that selects the baud rate you wish. The table on the left shows the CB-command settings for different baud rates with no parity and 1 stop bit.</p> <p>For example, to change the baud rate to 115200, at the "&gt;" prompt in the communication window, type <b>cb811</b> then press the Enter key.</p> <p> The <b>CB?</b> command will identify the communication setting.</p>
--

<pre>&gt;cb? CB = 411 ----- Serial Port Control (Baud [4=9600]; Par; Stop) &gt;cb811 &gt;CK [Parameters saved as USER defaults] &gt;cb? CB = 811 ----- Serial Port Control (Baud [8=115200]; Par; Stop) &gt;</pre>	<p><i>TRDI Toolz</i> will send the command <b>CK</b> to save the new baud rate setting.</p> <p>Exit the program.</p> <p>The ADCP is now set for the new baud rate. The baud rate will stay at this setting until you change it back with the CB command.</p> <p> Exit <i>TRDI Toolz</i> so the communication port is available for use with other programs.</p>
--	---

# Caring for your Workhorse System

This section contains a list of items you should be aware of every time you handle, use, or deploy your WorkHorse. *Please refer to this list often.*

## General Handling Guidelines

- Never set the transducer on a hard or rough surface. **The urethane faces may be damaged.**
- Always remove the retaining strap on the underwater-connect cable and dummy plug when disconnecting them. **Failure to do so will break the retainer strap.**
- Do not apply any upward force on the end-cap connector as the I/O cable is being disconnected. **Stressing the connector may cause the ADCP to flood.** Read the Installation section for details on disconnecting the I/O cable.
- Do not expose the transducer faces to prolonged sunlight. **The urethane faces may develop cracks.** Cover the transducer faces on the WorkHorse if it will be exposed to sunlight.
- Do not expose the I/O connector to prolonged sunlight. **The plastic may become brittle.** Cover the connector on the WorkHorse if it will be exposed to sunlight.
- Do not store the ADCP in temperatures over 60 degrees C with the batteries removed. **The urethane faces may be damaged.**
- Store batteries in a **cool dry location** (0 to 21 degrees C). If the batteries are installed in the ADCP, do not store the ADCP in temperatures over 21 degrees C.
- Do not store batteries inside the ADCP for extended periods. **The batteries may leak.**
- **Use batteries within one year of the Manufacture date (use by Warning date).** A battery pack used to start a deployment prior to the Warning Date means that it will perform as expected and provide the required power for any deployment that was created using the TRDI planning module. For example, if your deployment is going to be 12 months long and the battery label shows it is nine months old, it is safe to use the battery.
- Vent the system before opening by loosening the hardware on the housing. **If the ADCP flooded, there may be gas under pressure inside the housing.**
- Do not scratch or damage the O-ring surfaces or grooves. **If scratches or damage exists, they may provide a leakage path and cause the ADCP to flood.** Do not risk a deployment with damaged O-ring surfaces.
- Do not lift or support a WorkHorse by the external I/O cable. **The connector or cable will break.**

## Assembly Guidelines

- Read the Maintenance section for details on WorkHorse re-assembly. Make sure the housing assembly O-ring stays in the groove when you re-assemble the WorkHorse. Tighten the hardware as specified. **Loose, missing, stripped hardware, or a damaged O-ring can cause the WorkHorse transducer to flood.**
- Use light amounts of silicone lubricant (included with the spare parts kit) on both the male pins and female socket to help seat the cable connectors. Wipe off excessive silicone from the metal portions of the pins. **Regular lubrication is required: Apply dry type silicone lubricant prior to each connection.**

- Do not connect or disconnect the I/O cable with power applied. When you connect the cable with power applied, you may see a small spark. **The connector pins may become pitted and worn.**
- The WorkHorse I/O cable may be connected while slightly wet; **do not connect under water.**

## Deployment Guidelines

- Read the *VmDas* and *WinRiver II* guides. **These guides have tutorials to help you learn how to use the software.**
- WorkHorse Sentinel batteries are shipped inside the ADCP but not connected. **Connect the battery and seal the ADCP before deployment.**
- Align the compass whenever the batteries are replaced, the recorder module is replaced, or when any ferrous metals are relocated inside or around the WorkHorse housing. **Ferro-magnetic materials affect the compass.**



When the batteries are replaced, the compass must be calibrated (see [Compass Calibration](#)).

- The AC power adapter is not designed to withstand water. **Use caution when using on decks in wet conditions.**
- Avoid using ferro-magnetic materials in the mounting fixtures or near the WorkHorse. **Ferro-magnetic materials affect the compass.**



# Chapter 2

## INSTALLATION

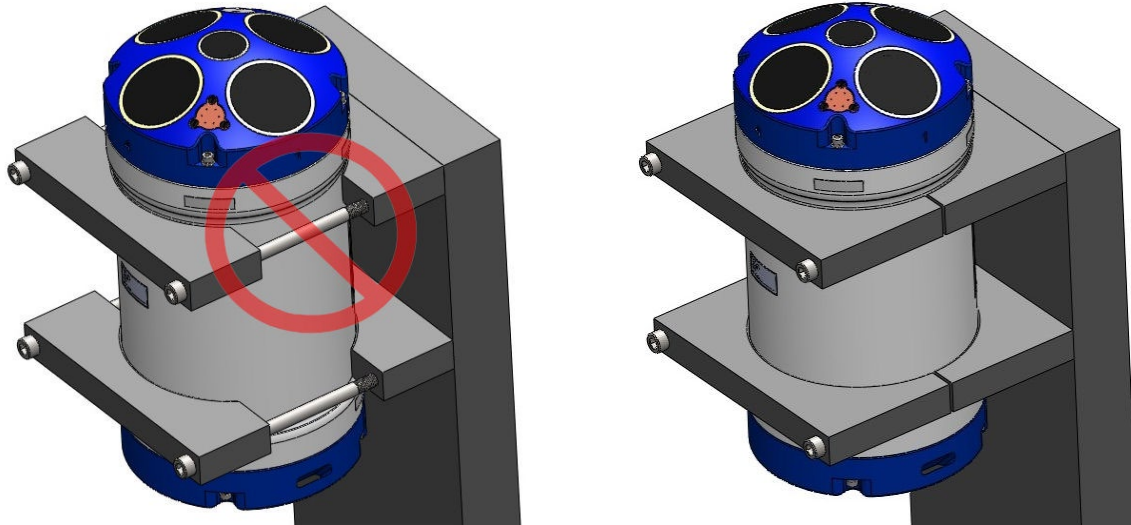


In this chapter, you will learn:

- How to connect/disconnect the I/O cable
- How to connect the optional external battery case
- Cable wiring diagrams
- Available mounts for the WorkHorse ADCP

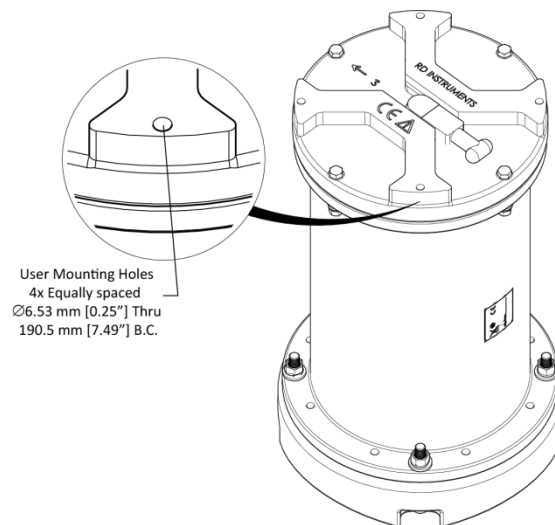
# Mounting the Instrument

The preferred method of mounting the WorkHorse is using clamps that grip the circumference of the housing. The fallback method of mounting the instrument is to use the holes on the end-cap. See the [Outline Installation Drawings](#) for dimensions.




Poor Design	Good Design
<p>When clamping the WorkHorse to a mount, the clamp must not have a large gap between the front and rear clamp. Using this type of design can cause the housing to deform or even break if the clamps are over tightened. This will cause the ADCP to flood.</p>	<p>Design clamps that fully surround the housing. Design the gap as small as possible so that when the clamp is fully tightened it will not deform the housing or cause excessive pressure on the housing.</p>

**Figure 12. Mounting the Instrument with a Clamp Design**



**Figure 13. End-Cap User Mounting Holes**

 Only use stainless steel hardware.

# I/O Cable and Dummy Plug

The underwater connector (on the housing) and the I/O cable and dummy plug are molded wet-mate connectors.



The dummy plugs should be installed any time the cable is removed. Use the dummy plug when the ADCP is in storage or is being handled.



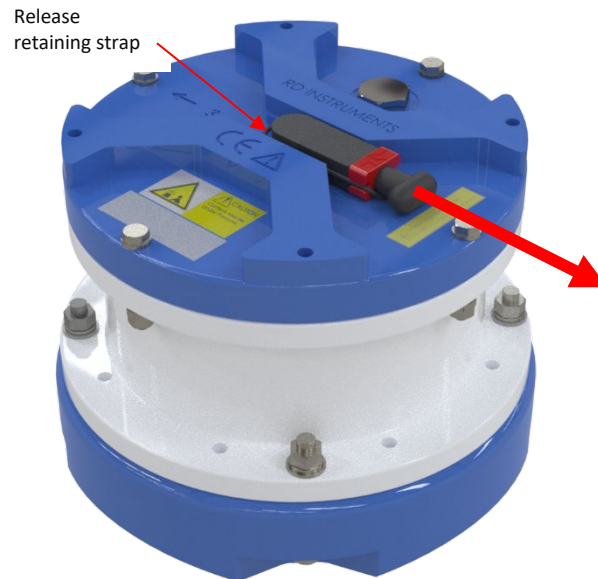
When disconnecting or connecting the WorkHorse I/O cable, do not apply any upward force on the connector. Applying an upward angle as the cable is disconnected or connected puts stress on the connector. This may cause several serious problems:

- The connector or connector pins can crack.
- The O-ring on the bottom of the connector can be damaged.
- The molded urethane on the connector may separate from the brass insert.

If the connector is damaged in any of these ways, your WorkHorse will flood.

## To disconnect the cable:

- Release the retaining strap/Cable Clip with O-Ring by pulling it over the connector.
- Grasp the cable close to the housing (see Figure 14). Your thumb should rest on top of the connector or against the edge of the housing. *Do not try to fit your hand under the cable as it passes over the housing.* This is what causes the upward force!
- Pull the cable straight out away from the housing with a gentle rocking motion. Do not apply any upward force on the connector as it is being disconnected.



**Figure 14. Removing the I/O Cable**

## To connect the cable:

- Check all pins for signs of corrosion (greenish oxidation, black deposits, or pitting).
- Use light amounts of silicone lubricant (included in the Spare Parts kit) on both the rubber portion on the male pins and female socket to help seat the cable connectors. Wipe off excessive silicone from the metal portions of the pins. **Regular lubrication is required:** Apply silicone lubricant prior to each connection.



When the cable is connected without any lubricant, excessive force is needed to fully seat or remove the connector. This can cause several serious problems:

- The neoprene rubber portion of the contact pin may tear from the metal pin.
- Wiggling the cable side-to-side to overcome the friction as it is connected or disconnected may cause the neoprene rubber to tear or create pin-holes on the side of the connector.

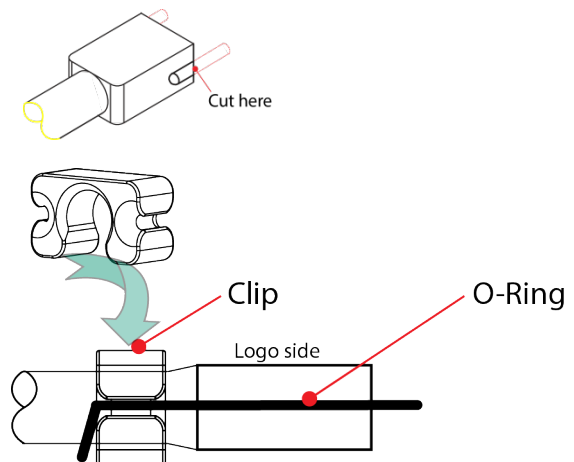
As a result of any damage to the neoprene rubber, corrosion may occur on current carrying pins.

3. Gently push the cable straight in toward the connector. Do not apply any upward force on the connector as it is being connected.
4. Roll the retaining strap/Cable Clip with O-Ring over the connector.

## Using the Cable Clips

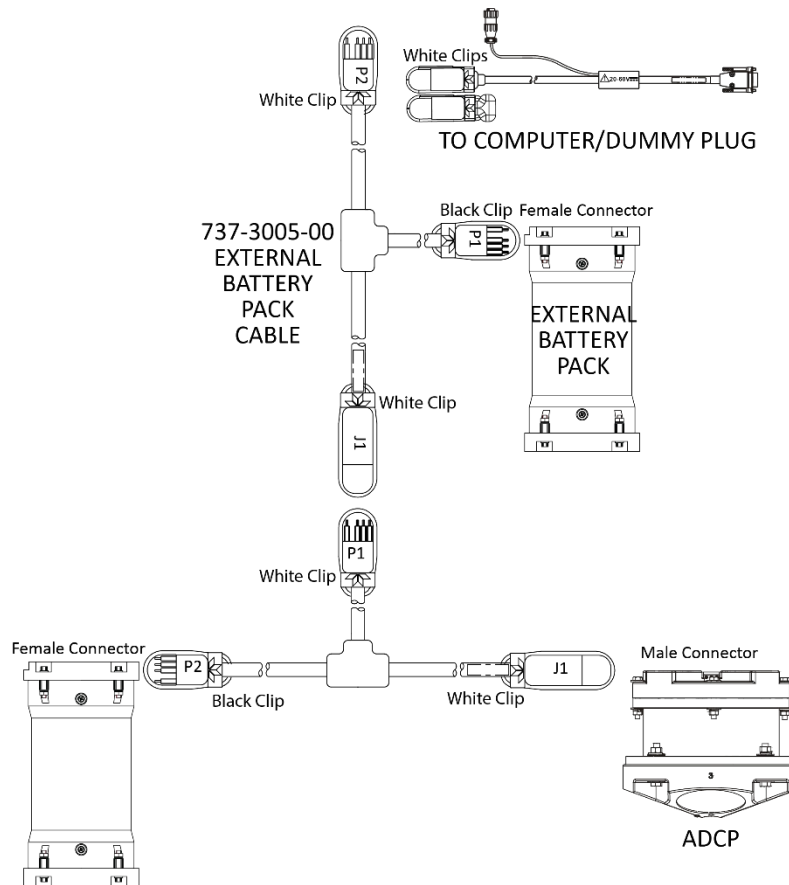
New dummy plugs and cables no longer use a molded retaining strap. To use the cable clips:

1. Remove the broken retaining strap if needed.
2. Snap the clip onto the cable or dummy plug.
  - Black clip & 2-137 O-ring = cables
  - White clip & 2-130 O-ring = dummy plugs
3. Route the O-ring through the clip. Connect the cable/dummy plug and then stretch O-ring over connector.

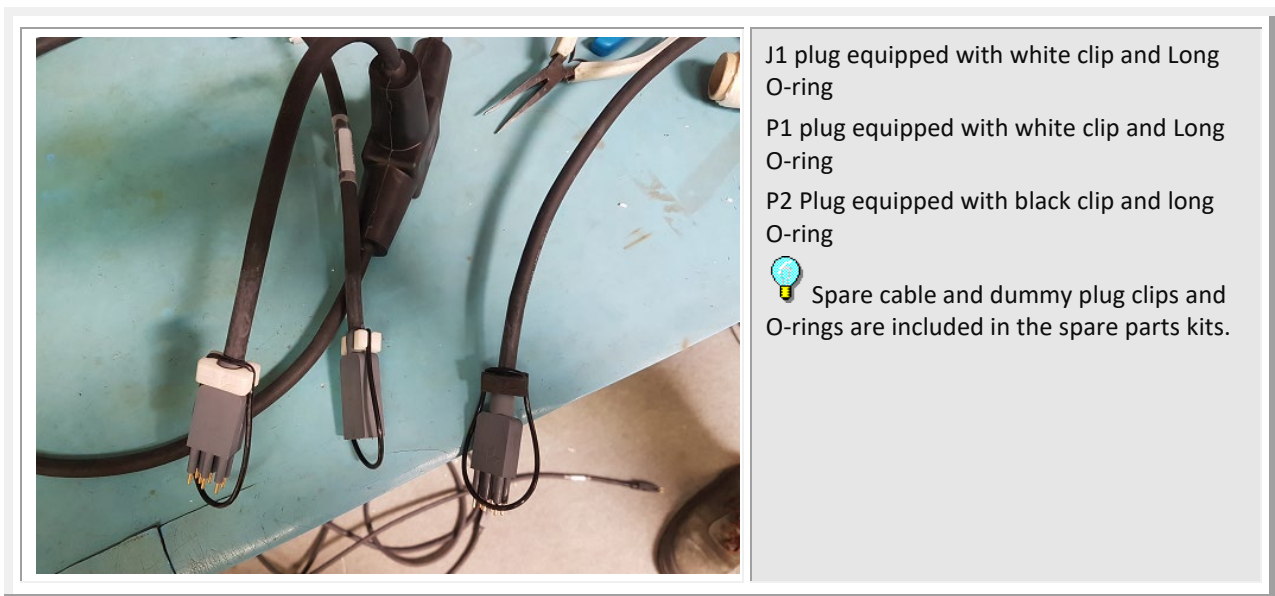


# Connecting the External Battery Case

The optional External Battery Pack holds two 450 Watt-hours (Wh) batteries. To avoid affecting the compass, place the external battery case at least 30-cm away from the ADCP.



**Figure 15. External Battery Pack Connection**







The 3<sup>rd</sup> plug on the Y cable may not be used when there is only one External battery case or when the customer is not using a direct connection with the ADCP. In this case, use the Dummy plug from the ADCP to protect the 3<sup>rd</sup> plug on the Y cable.



For the P1 plug on the Y Cable 737-3005-00, use two white clip with the long O-ring. This solution works for both the cable connector or for the Dummy plug (New and old design) when you are not using the 3<sup>rd</sup> Plug on the Y cable.



The P2 Plug on the Y cable needs to be connected on the Female connector on the External Battery pack.  
Use a Black Clip with the long O-ring.

# Routing Cables

Several cables connect to the Mariner ADCP system (see Figure 18). Use care when routing these cables through bulkheads, deck plates, cable runs, and watertight spaces. Make allowances in cable length and engineering design plans for cable routing. When necessary, use strain reliefs on the cables.

The Input/Output (I/O) cable connects the ADCP to the Deckbox (Mariner systems) or computer. We deliver the cable with both connectors attached. The transducer-end connector is molded on, so you can use it below the waterline. The cable is custom-made in lengths specified by the user. Route this cable so:

- You can install it with the connectors attached.



You can order the cable with the Deckbox end connector removed for easier cable routing, but this requires soldering the cable connections at your installation site. This is a difficult task (see [Mariner I/O Cable Dry End Connector Assembly](#)).

- It does not have kinks or sharp bends.
- Protect the cables with hose if zip-ties are used to secure them to structures (see Figure 16 and Figure 17).
- You can easily replace it if it fails.
- The Mariner dry-end connector OD is 3.89cm (1.530 inches) and is 5.02cm (1.976 inches) long. Model# Souriau 85106RC2024P50.
- The wet-end connector is 3.0cm (1.18 inches) long, 2.54cm (1.00 inches) wide, 1.27cm (0.5 inches) high. Model# Impulse LPMIL-7-FS.

Other cables that may need routing to the chassis include the computer interface and the navigation interface. You may also need to route External Battery case cables.



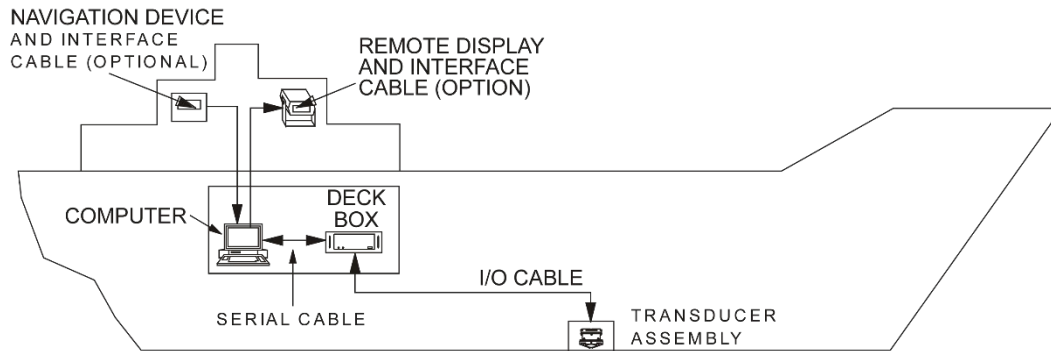
**Figure 16. Do not use Zip-Ties Directly on Cables**



When attaching the ADCP cables to your mount, do not zip-tie the cables directly to the structure. Zip-ties slowly cut through the cable's outer jacket and cause leaks.



**Figure 17. Cables Protected with Abrasion Resistant Sleeving**



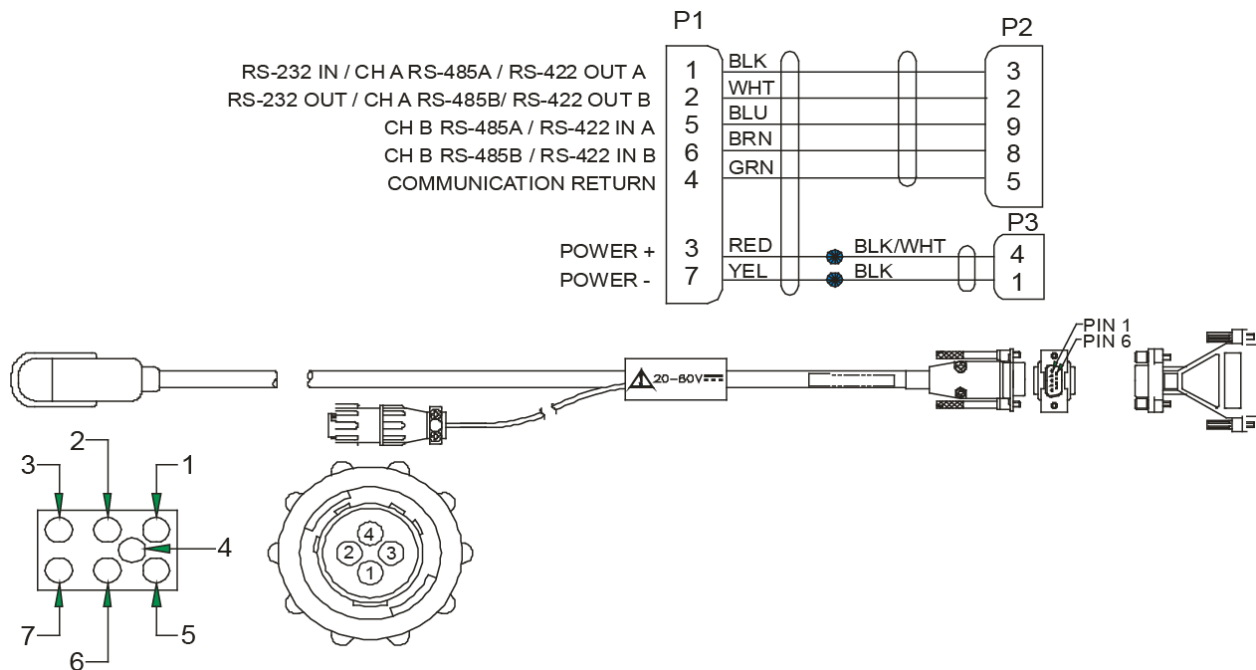
**Figure 18. Typical Mariner Interface Cable Layout (Overview)**



# Cable Wiring Diagrams

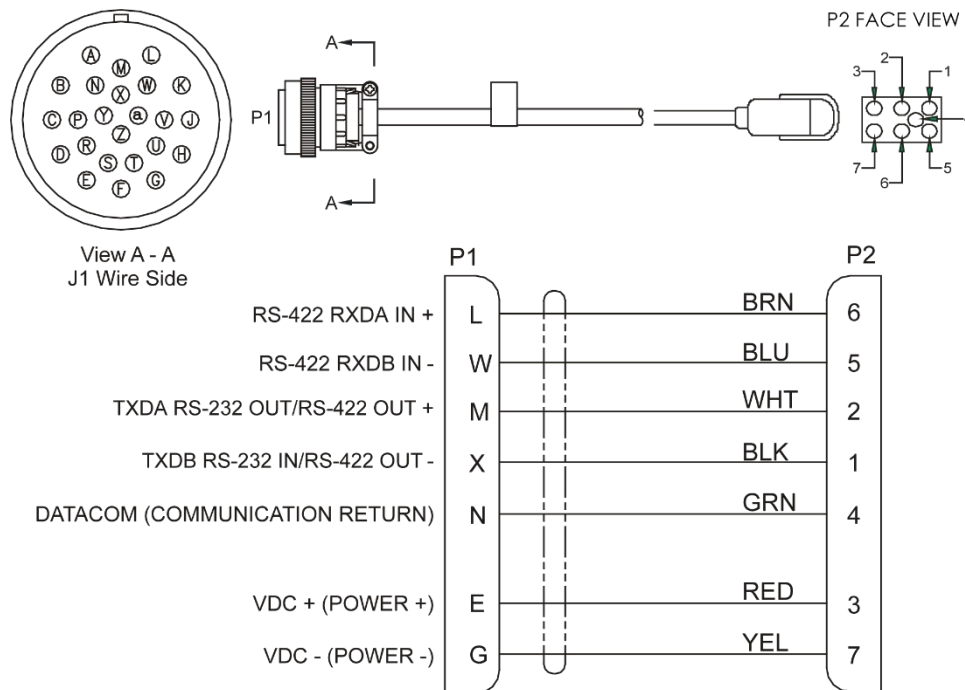
This section has information on WorkHorse cabling. Special user-requests may cause changes to the basic wiring system and may not be shown here. If you feel there is a conflict, contact TRDI for specific information about your system. The following figures show various WorkHorse cable locations, connectors, and pin-outs.

Where shown, the color code is for reference only; your cable may be different.

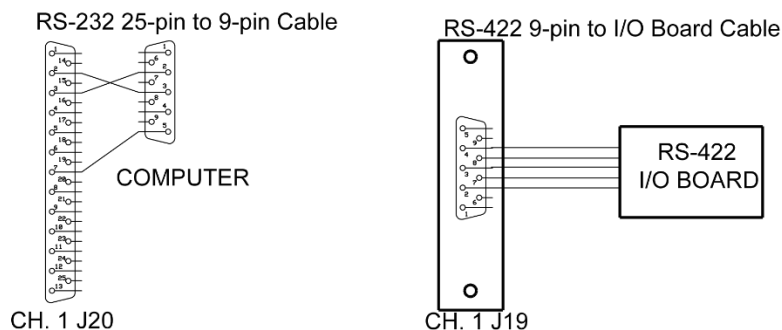


**Figure 19. Monitor and Sentinel I/O Cable Wiring**

Where shown, IN refers to signals going into the ADCP and OUT refers to signals coming out of the ADCP.



**Figure 20. Mariner I/O Cable Wiring 737-3036-xxx**



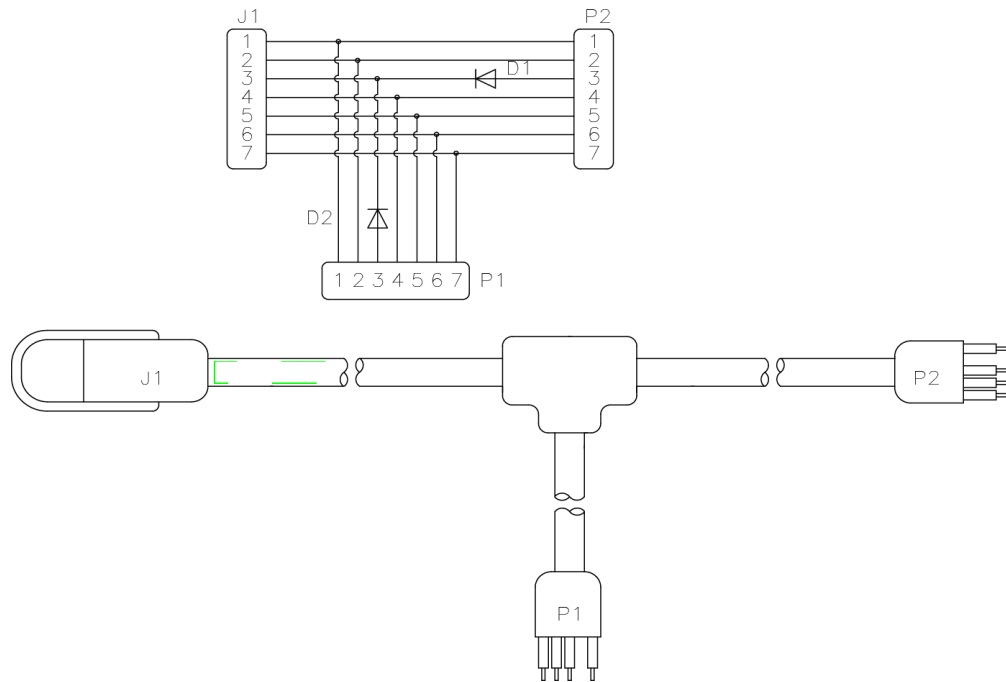
Cable Type	ADCP Signal	Chassis	Computer	Computer Signal
RS-232 25-pin to 9-pin	DATA IN	2	3	DATA OUT
	DATA OUT	3	2	DATA IN
	GND	7	5	GND
RS-422 9-pin to I/O board	DATA IN A	2	-	DATA OUT A (+)
	DATA OUT A	4	-	DATA IN A (+)
	COMMON	3	-	COMMON
	DATA IN B	7	-	DATA OUT B (-)
	DATA OUT B	8	-	DATA IN B (-)

**Figure 21. Mariner Deckbox to Computer Serial Cable**

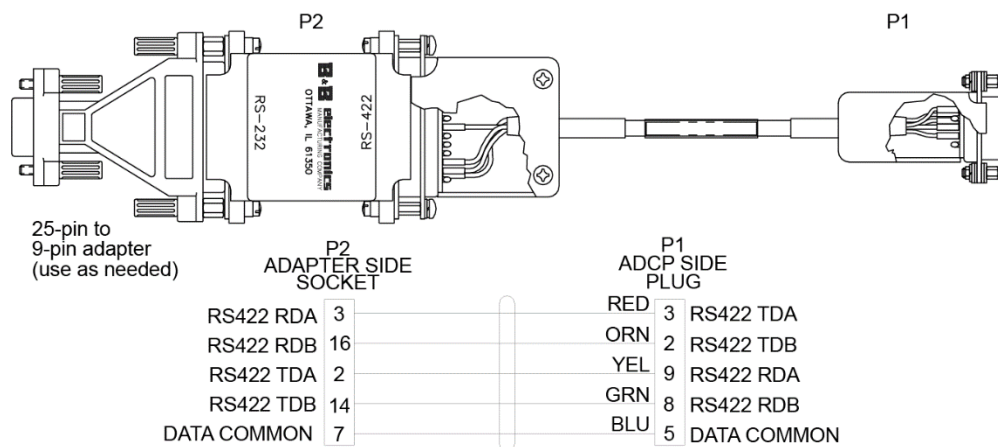


These cables provide RS-232 or RS-422 communications. One cable is provided with the instrument: 25-pin Female to 9-pin male RS-232 cable (P/N 730-6003-00). The cable is about 2-meters long and has a diameter of 8 mm (0.31 in.).

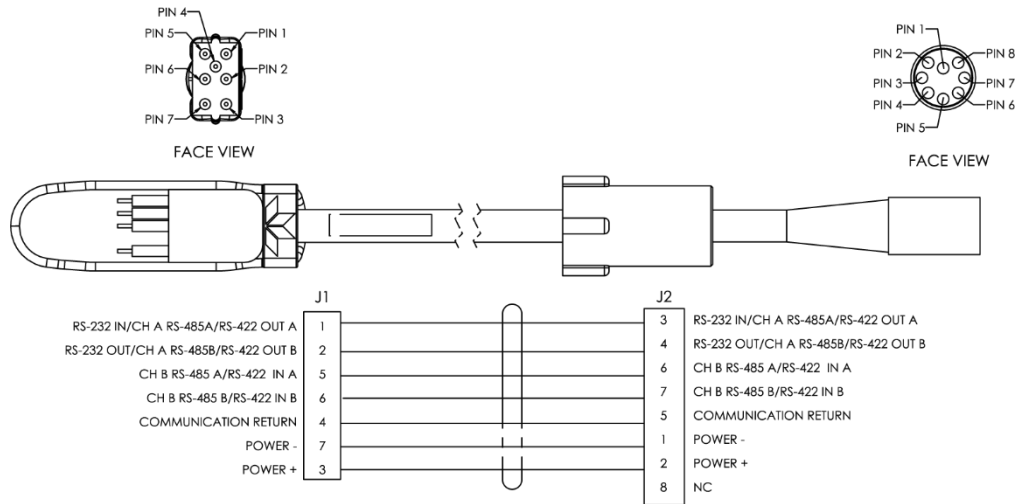
For cable lengths longer than 15 meters, we recommend you use RS-422 communications. The cable for RS-422 communication is not provided with the equipment.



**Figure 22. External Battery Pack "Y" Cable**



**Figure 23. 737-3010-00 RS232-to-RS422 Converter Wiring (25-Pin to 9-Pin)**



**Figure 24. Optional 737-3171-00 Conversion Cable (0.5 meter) Wiring**



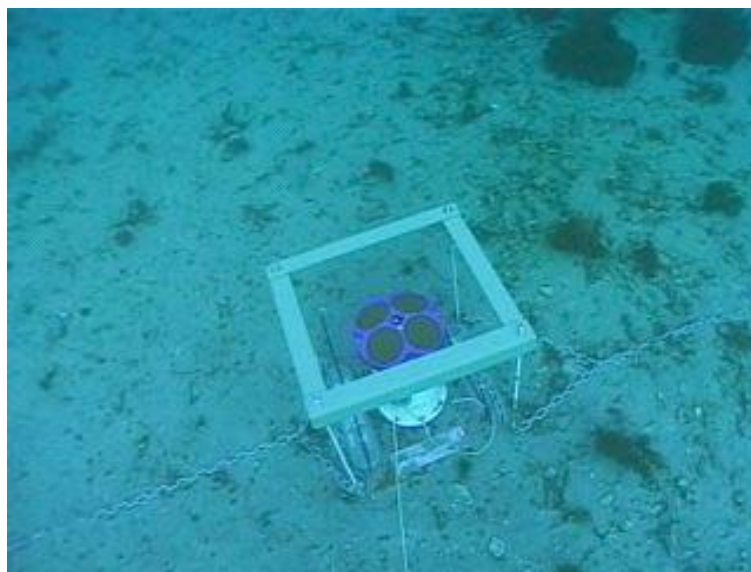
The adapter cable allows the 8-pin MCIL to mate with the 7-pin LPMBH.

# Bottom Mounts

Bottom mounts can range from simple PVC frames to Trawl Resistant Bottom Mounts. Below is a sample of some of the types of bottom mounts available for WorkHorse ADCPs.

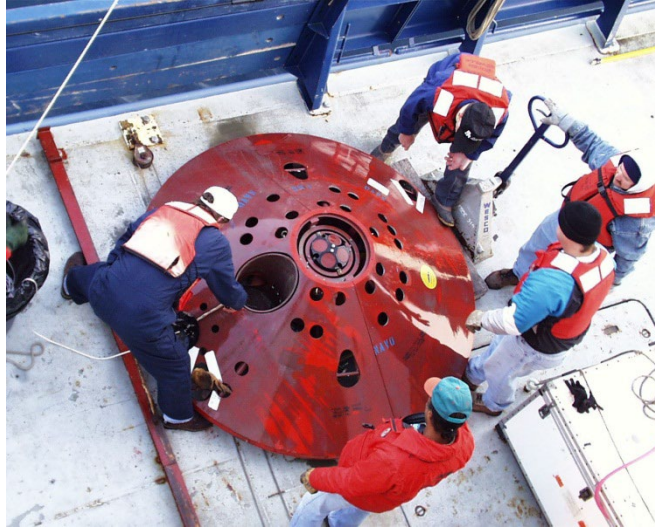


**Figure 25.** Teledyne RD Instruments Sea Spider Bottom Mount



**Figure 26.** View from the Bottom

Photo courtesy of John Skadberg, US Navy SPAWAR System Center in San Diego, CA. Sent to TRDI by Steve Monismith.

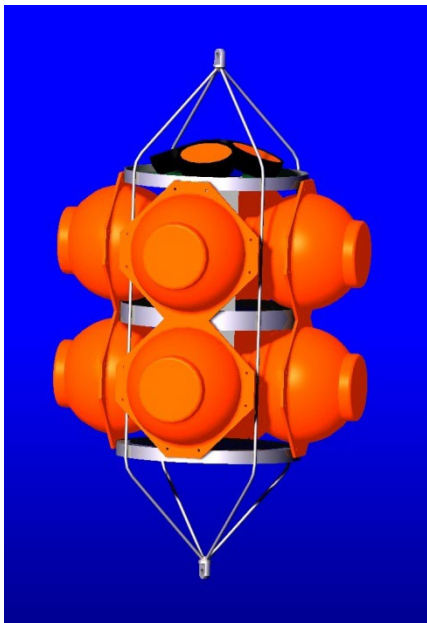


**Figure 27. Trawl Resistant Bottom Mount**

Photo courtesy of Maureen Wieler, Mooring Systems.

## Buoy Mounts and Load Cages

Buoy mounts and load cage frames are designed to allow the WorkHorse to profile unobstructed by the mooring hardware. Below is a sample of some the types of buoy and load cage mounts available for WorkHorse ADCPs.



**Figure 28. Deep-Water Mount**

Photo courtesy of the Oceanscience Group.



**Figure 29. Buoy Mount with External Battery**

Photo courtesy of Maureen Wieler, Mooring Systems.





**Figure 30. Subsurface Buoy**

Photo courtesy of Patrick Lefeuve, Technicap. The Subsurface buoy was developed by BMTI and Technicap.



**Figure 31. Buoy Mount**

Photo courtesy of Flotation Technologies.



**Figure 32. Load Cage**

Photo courtesy of Angela Cates, UNM.

## Over-the-Side Mounting

The over-the-side mount is common if you want the ability to move the ADCP from one platform to another. Make the mount as rigid as possible to limit the amount of pitch and roll applied to the ADCP. Although the tilt sensor can measure a  $\pm 20^\circ$  influence, anything beyond  $15^\circ$  will cause bias to the data that

cannot be removed. No matter what mounting style is used, the ADCP must be below the bubble layer. Bubbles will cling to the urethane faces of the ADCP and reduce the range to almost nothing. Usually a mount somewhere aft of amidship is used. A stern mount will cause all sorts of problems due to propeller wake, bubbles, and turbulent water conditions.

The most common over-the-side mounting method for WorkHorse ADCPs uses a Kentucky Mount style. For more information, see the following:

- <http://hydroacoustics.usgs.gov/movingboat/pdfs/KYMount.pdf>
- [http://hydroacoustics.usgs.gov/movingboat/mbd\\_deployments.shtml](http://hydroacoustics.usgs.gov/movingboat/mbd_deployments.shtml)

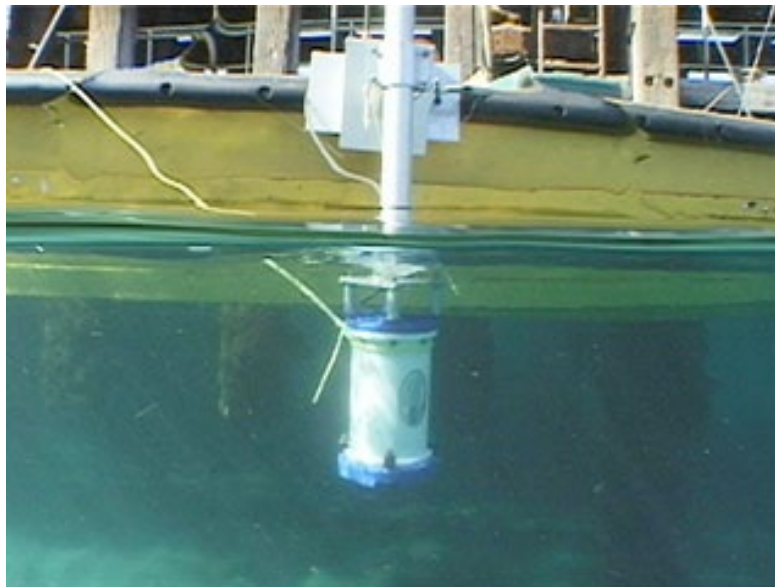


Our transducer assembly is sturdy, but TRDI did not design it to withstand collisions with all floating objects. TRDI strongly suggests protecting the ADCP if this is a possibility.



Avoid using ferro-magnetic materials in the mounting fixtures or near the ADCP. They affect the compass. Use 316 stainless steel hardware.

The WorkHorse ADCP has mounting holes on the end-cap. See the [Outline Installation Drawings](#) for weights.



**Figure 33. Over-the-Side Mount**

Photo courtesy of John Skadberg, US Navy SPAWAR System Center in San Diego, CA. Sent to TRDI by Steve Monismith.

## Over-the-Side Mounting Special Considerations

Use the following suggestions when mounting the ADCP to a platform:

- It is desirable to rigidly mount the ADCP to the platform. You want to avoid the free spinning of the ADCP in this application. The ADCP must stay in the water at all times.
- The ADCP must be mounted deep enough so that turbulence caused by its movement through the water does not allow air bubbles to be attached to the transducer faces.
- Avoid mounting the ADCP near motors and thrusters. They cause air bubbles and will cause bias to the internal compass.
- Avoid mountings that will cause the ADCP to see severe accelerations.



# In-Hull Mounting

The in-hull mounted ADCP is common when it is intended to keep the system on a single vessel or when over-the-side mounting is not practical for your vessel. For this type of mounting, there are issues of beam clearance and access.

## Transducer Head Mounting Considerations

You must consider several potential problems before installing the transducer head assembly. Read this section before deciding where to install the transducer assembly. See the outline installation drawings for specifications on our standard ADCP transducer heads.

## Mounting Plate Overview

The Mariner mounting plate is a bronze plate that helps mount the transducer head to a vessel. The overall dimension of the mounting plate is  $\varnothing 311.1$  (12.25 inches) and the bolt hole pattern is 16 equally spaced  $\varnothing 8.20$  through holes on a  $\varnothing 285.75$  bolt circle.



See the [outline installation drawings](#) for the exact dimensions and weights.

## Location

Ideally, you want to install the transducer head:

- Where it is accessible both internally (for access to transducer electronics) and externally (to remove biofouling).
- Away from shipboard protrusions that reflect ADCP energy. Allow for a reflection-free clearance of  $15^\circ$  around each beam (see the outline installation drawings).
- Away from other acoustic/sonar devices, especially those operating at the same frequency (or harmonic) of the ADCP.
- Close to the ship's fore-to-aft centerline. As distance from the centerline increases, vertical accelerations caused by the roll of the ship also increase. These accelerations can cause additional uncertainties in ADCP velocity measurements.

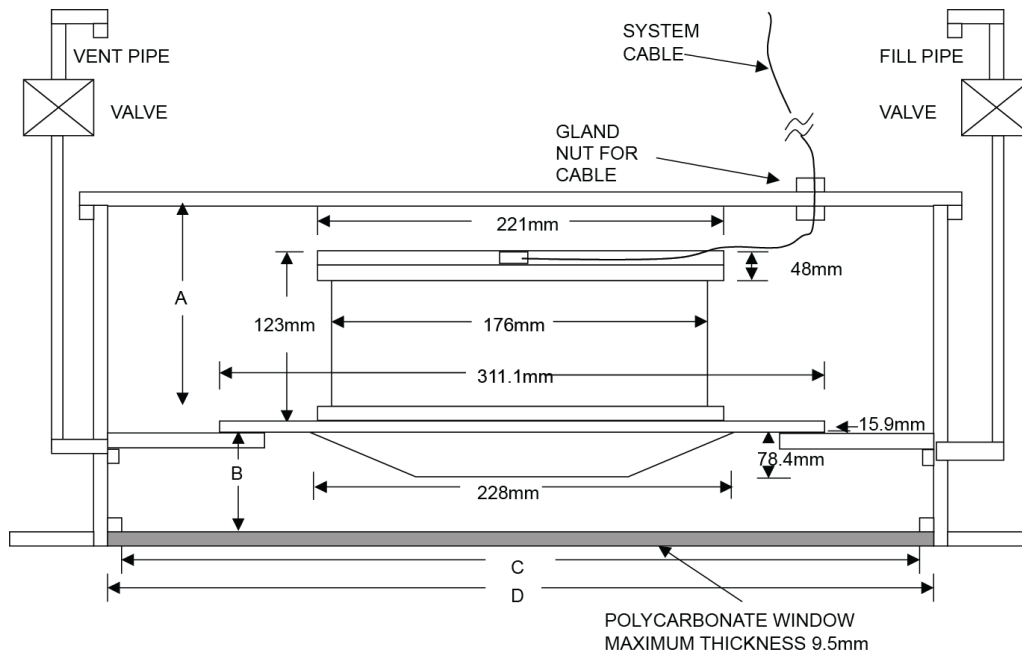
Other considerations may be:

- Ease of installation.
- Portability (wanting to move the instrument from vessel to vessel).
- Permanent installation.

With all of these choices there are good and bad points. We will show you several options for installation and then go through specific concerns that you may have to deal with once you install or mount the ADCP.

## Sea Chest In-Hull Mounting

A sea chest (Figure 34 and Figure 35) is a fixture that surrounds and holds the transducer head, protecting it from debris in the water. The bottom of the sea chest must be open to seawater to allow the acoustic beams to pass through freely. If using a sea chest interests you, call TRDI for the latest information.

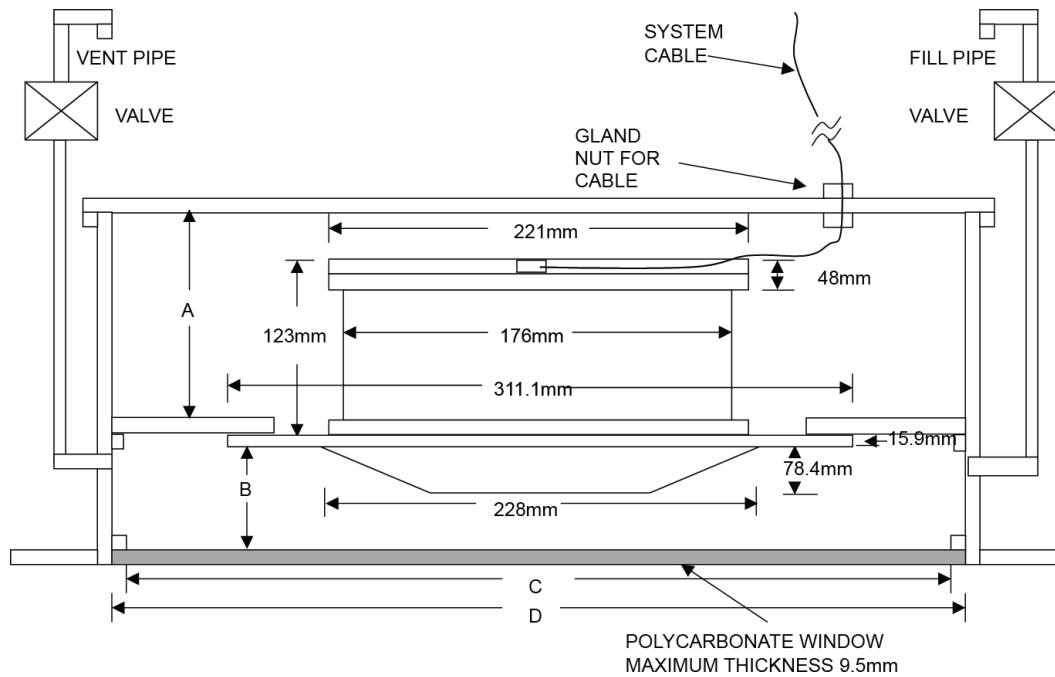


**Figure 34. Inside Vessel Mounting of a WorkHorse Mariner 300 kHz Transducer**

Dimension Letter	Option 1 Minimum Dimension	Option 2 Maximum Dimension
A	275.4mm	275.4mm
B	84.7mm	91.1mm
C	362mm	362mm
D	412mm	412mm

**Special Notes:**

1. No liability is assumed by Teledyne RD Instruments for users using this conceptual well drawing. Users realize that this drawing is provided as a basis for the user to construct their own well. It is expected that the user will have their well design inspected and approved by a naval architect.
2. The top plate of the well is intended as the primary seal for the vessel. The window and transducer can provide additional seal but should not be considered the primary sealing mechanism for the vessel.
3. This conceptual well drawing is designed such that it would be possible to remove the transducer from inside the vessel. For safety, it is strongly recommended that divers fit a steel plate either over the window or in place of the window before installing or removing the transducer.
4. The listed minimum and maximum dimensions are recommendations based on maintaining the clearance for the transducer as well as providing the smallest well possible.
5. The gasket material between the transducer housing and the vessel flange should be used that will both seal and provide electrical isolation between the transducer housing and the vessel flange. Typical gasket material used is silicone rubber 3-6.35mm thick.
6. Inserts in the transducer housing mounting holes may be used to provide additional isolation from vessel.
7. The walls of the well should be coated with a material to absorb reflected sound in the well. Material such as 3mm wet suit material glued to the inside well walls is satisfactory for this purpose.
8. Vent and fill pipes should be above the water line of the vessel and it is recommended that a gate valve be installed to seal off these pipes.
9. Window thickness should not exceed 9.5 mm of Polycarbonate material. Thinner Polycarbonate window is OK.
10. Window faces should be parallel to the transducer face to within 2 degree for best performance; angle should never exceed 5 degrees.



**Figure 35. Underneath Vessel Mounting of a WorkHorse Mariner 300 kHz Transducer**

Dimension Letter	Option 1 Minimum Dimension	Option 2 Maximum Dimension
A	275.4mm	275.4mm
B	84.7mm	91.1mm
C	362mm	362mm
D	412mm	412mm

**Special Notes:**

1. No liability is assumed by Teledyne RD Instruments for users using this conceptual well drawing. Users realize that this drawing is provided as a basis for the user to construct their own well. It is expected that the user will have their well design inspected and approved by a naval architect.
2. The top plate of the well is intended as the primary seal for the vessel. The window and transducer can provide additional seal but should not be considered the primary sealing mechanism for the vessel.
3. This conceptual well drawing is designed such that it would be possible to remove the transducer from beneath the vessel while in dry dock.
4. The listed minimum and maximum dimensions are recommendations based on maintaining the clearance for the transducer as well as providing the smallest well possible.
5. The gasket material between the transducer housing and the vessel flange should be used that will both seal and provide electrical isolation between the transducer housing and the vessel flange. Typical gasket material used is silicone rubber 3-6.35mm thick.
6. Inserts in the transducer housing mounting holes may be used to provide additional isolation from vessel.
7. The walls of the well should be coated with a material to absorb reflected sound in the well. Material such as 3mm wet suit material glued to the inside well walls is satisfactory for this purpose.
8. Vent and fill pipes should be above the water line of the vessel and it is recommended that a gate valve be installed to seal off these pipes.
9. Window thickness should not exceed 9.5 mm of Polycarbonate material. Thinner Polycarbonate window is OK.
10. Window faces should be parallel to the transducer face to within 2 degree for best performance; angle should never exceed 5 degrees.

# Mounting Considerations

Now that we have shown you the main methods of mounting the ADCP, you must be aware of issues that may cause reduction in range, biased data, fouling, and other performance related considerations.

## Orientation

We recommend you mount the transducer head with Beam 3 rotated to a ship-relative angle of 45° (Figure 37 shows beam orientation). This causes the magnitude of the signal in each beam to be about the same. This improves error rejection, reduces the effect of ringing (see [Acoustic Isolation](#)), and increases the ADCP's effective velocity range by a factor of 1.4. If you align Beam 3 at an angle other than zero, you must nullify this offset. You can do this using a direct command (see the WorkHorse Command Guide) or through our *VmDas* program.

Use the ship's roll and pitch reference to mount the transducer head as level as possible. If the head is not level, depth cell (bin) mapping will be incorrect. Large misalignments can cause large velocity measurement errors. If you cannot mechanically make the transducer head level, you can use *VmDas* to enter off-set values for roll and pitch.

## Fairing

Fairings are structures that produces a smooth outline and reduces drag or water resistance. The fairing also diverts floating objects away from the transducer. A fairing that is shaped like a teardrop, sloped such that the leading edge (closer to the bow) is higher than the back edge, and extends below the hull (typically 12 inches) will divert the air bubbles away from the transducer faces.

## Acoustic Window

While we do not fully understand windows, we do believe that windows can be used to produce overall performance improvements in vessel-mounted ADCPs. Additionally, if the ship operates where there is danger of barnacle damage or a high density of ice or other floating objects, then the use of an acoustic window is the only option.

It is theoretically possible to use a window successfully; however there are several advantages and disadvantages to consider before using an acoustic window.

### Advantages

- Well will not fill with air bubbles caused by the ship moving through the surface water, see [Sea Chest In-Hull Mounting](#).
- Flow noise is reduced, see [Flow Noise](#).
- The well can be filled with fresh water to limit corrosion.
- Barnacles cannot grow on the transducer faces. Barnacle growth is the number one cause of failure of the transducer beams.
- The transducer is protected from debris floating in the water.

### Disadvantages

- The range of the ADCP will be reduced because the window can and will absorb some of the transmit and receive energy.
- The transmit signal could be reflected into the well, causing the well to “ring” like a bell. This will cause the data being collected during the ringing to be biased. Some ships have reported a loss in range as great as 50 meters. The ringing may be dampened by applying sound absorbing material on the well walls (TRDI does not have any recommendations for sound absorbing material), see [Ringing](#).
- The transmit signal could be reflected off the window and back into the other beams.

Our experience has allowed us to put together some minimum specific recommendations:

**Window orientation.** The acoustic window should be flat and parallel to the transducer mounting plate. Note this is not an absolute requirement. However, if the water temperatures inside the window and outside the window are not the same, all four beams will be refracted and actual velocity components will be rotated into a new coordinate system. In particular, some of the horizontal velocity will appear as a vertical velocity.

**Window material.** Important acoustic properties of the window include acoustic refractive index (which should be as close as possible to that of water), insertion loss (which should be as small as possible) and speed of sound. There are two acoustic refractive indices: one for shear waves and one for plane waves. The acoustic refractive indices are simply the ratios of speed of sound in water to speed of sounds in the material. Insertion loss combines absorption and reflection of sound, and it depends on both the thickness and the material properties of the window. In particular, you should avoid using window thickness equal to odd multiples of shear mode quarter-waves (Dubbelday and Rittenmeyer, 1987; Dubbleday, 1986). Refer to Selfridge (1985) and Thompson (1990) for more information. Note that the speeds of sound in plastics decrease with increasing temperature and that causes the resonant frequencies to shift. This can be a large effect. Neither Selfridge nor Thompson has much information on the temperature coefficients of sound speeds.

Our experience has shown that Polycarbonate windows are very good for the Ocean Surveyor/Observer (OS), WorkHorse (WH), and Broadband (BB) ADCPs. The thickness of the materials depends on the frequency you intend to use. Table 3 will help to choose the maximum thickness you should use.



One concern with window selection is that it be able to support the weight of the water inside the well once the ship is dry-docked. TRDI recommends that you always fill/drain the well at the same time that you are either filling/drain the dry dock area.

**Table 3: Window Thickness**

Frequency	Recommended Thickness	Maximum Thickness
75	1 inch	2 inches
300	0.375 inches	1 inch
600	0.25 inches	0.5 inches
1200	0.25 inches	0.5 inches

**Spacing between window and transducer.** The primary geometrical factor in design of windows is the reflection of one beam into another beam, causing crosstalk between the beams. The distance from the window should be at least 0.25 inches and no more than 0.5 inches for optimal set up.

**Window aperture.** The window aperture must be sufficient to pass the beams without causing diffraction. If the window is placed next to the transducer, then the aperture diameter should be the same as the distance between transducer cup corners. If the window is placed away from the transducer, then the aperture should be larger than all four beams plus about one transducer ceramic diameter.

## Free Flow and Windows

If filling and draining the well is an issue, then you may want to use a window but allow the water to freely exchange from outside the well to inside the well.

Our Japanese representative uses 0.25 inch thick Low Density Polyethylene (LDPE). He then drills two 30mm holes in the window along the edges. The inside walls are painted with anti-fouling paint. This allows the water to be full of anti-foulant during the time the ship is docked, which is when the barnacle growth occurs. The holes allow the water to exchange when the ship is in motion and allows for draining

when the ship is dry-docked (a 0.25" window will not support the weight of the water). He has never had a failure with the window, and has seen only a minimal loss in range (5-30 meters).

It is best if the window is parallel to the bottom edge of the transducer cups. The transducer cups are at a 30° angle. If the window is at an angle to the transducer, it will change the absorption. We do not have experience with different angles, but we have had customers use domes or have the window follow the contour of the ship bottom without real problems.

The optimum distance for the bottom of the transducer assembly from the window is 0.25 inches  $\pm$ 0.125 inches. Never allow the transducer to touch the window. The farther away the transducer cups are from the window, the more the sound is reflected off of one beam and then reflected into another beam.

**Acoustically-absorbing sea chest liner.** A sound absorbing material should be used inside the sea chest to minimize the effects of sound ringing within the sea chest. The material should be a minimum of one wavelength thick (include the sound speed of the absorbing material when calculating the size of a wavelength). Approximate wavelengths of sound in seawater are given below in Table 4. We do not have sufficient experience to recommend a specific absorbing material.

**Table 4: Wavelength of sound in seawater (1500 m/s sound speed)**

FREQUENCY (kHz)	WAVELENGTH (mm)
75	20
300	5
600	2.5
1200	1.25

**Fluid in the sea chest.** If you have not placed holes in the window and you are not going to work in an area where freezing is an issue, then the sea chest should be filled with fresh water. Fresh water decreases the issues of corrosion in the sea chest. If you will be in an area where freezing of fresh water would be an issue, then seawater can be used.



Only use Propylene Glycol and not Ethylene Glycol because the latter can harm the transducer urethane over time.

Some users have placed Propylene Glycol into the fresh water well to prevent freezing. TRDI recommends using a 40% Polypropylene Glycol + 60% freshwater mixture or 10% Polypropylene Glycol + 90% freshwater mixture depending on the water freezing temperature. Although this causes the water to have an inverted speed of sound (SoS) change to that of fresh water or salt water, SoS does not impact 2D velocities on a Phased Array Transducer.

You will have to perform post processing on the data sets from the Workhorse II. It must have the velocity data scaled properly based on the speed of sound in the sea chest. Propylene glycol causes the water to have an inverted speed of sound change to that of fresh water or salt water. This means that TRDI's standard software programs will not be scale the data properly. You will have to record separately the speed of sound in the sea chest and then in post processing correct the ADCP velocity data appropriately.

**Transducer calibration.** The factor used to correct velocity for speed of sound variations should be based on the speed of sound of the fluid inside the sea chest. Changes of speed of sound resulting from temperature changes may be computed from the temperature sensor on the transducer.

## Air Bubbles

Design your installation to minimize the volume of air bubbles in the path of the acoustic beams. Air bubbles attenuate (weaken) the signal strength and reduce the ADCP profiling range. Ships with a deep draft

or a non-flat bottom have fewer problems with bubbles. Ways to reduce bubble flow vary with ship characteristics, but two options are available. Mount the transducers below or away from the bubble layer.

- The flow layer is usually within the first two feet below the hull. Bubbles can get trapped in this layer. Mounting the transducer head amidship on the fore-to-aft centerline may help. For ships with propulsion systems that make large amounts of bubbles, use a mounting technique that lets you lower the transducer head below the hull while underway.



If you use locally made or existing extension hardware instead of the hardware available from TRDI, you may need to make an adapter plate to connect your hardware to our transducer head. Please call us for the exact dimensions and layout of our transducer head bolt holes for your system.

- Divert the bubble layer so it flows around the transducers - You can use fairings to alter the bubble flow. An acoustic window (see [Acoustic Window](#)) may help reduce the bubble problem, but can cause ringing (see [Acoustic Isolation](#)) and attenuation problems.

## Flow Noise

Water flowing over the transducer faces increases the acoustic noise level, which decreases the profiling range of the ADCP. You can reduce the flow across the transducer faces with a sea chest, fairing, or acoustic window.

## Corrosion and Cathodic Disbondment

Your ADCP is made of plastic and uses titanium bolts. The adapter plate (if used) may be naval bronze, aluminum, or other materials. Although the plastic ADCP will not corrode, the bolts and adapter plate may corrode.

Never attach anodes directly to the transducer head. Standard anode protection used for the ship should be installed outside of the well of the transducer head. Mounting of ship's standard anode protection outside of the transducer well will typically protect the parts that may corrode. However, you should plan regular inspections of mounting hardware and the adapter plate for signs of corrosion. Replace and parts that are questionable (corrosion can be further reduced if the well is covered with a window and then filled with fresh water).

## Ringing

The ADCP transmits an acoustic pulse into the water. The main lobe of this pulse bounces off particles in the water and the signals returned from these particles are used to calculate the velocity of the water.

As stated, the main lobe of the transmitted pulse is what we are using to process and calculate a velocity. The transmitted pulse, however, is made up of many side lobes off the main lobe. These side lobes will come in contact with transducer beam itself and other items in either the water or the well.

The energy from the side lobes will excite the transducer and anything bolted to the transducer. This causes the transducer and anything attached to it to resonate at the system's transmit frequency. We refer to this as "ringing."

If the ADCP is in its receive mode while the transducer is ringing then it will receive both the return signals from the water and the "ringing." Both of these signals are then processed by the ADCP. The ringing causes bias to the velocity data.

All ADCPs "ring" for some amount of time. Therefore, each ADCP requires a blanking period (time of no data processing) to keep from processing the ringing energy. Each ADCP frequency has a different typical ringing duration. The typical ringing period for each ADCP frequency is as follows; 75kHz is 8 meters, 300kHz ADCPs is 2 meters, 600kHz ADCPs is 1.5 meters, and 1200kHz ADCPs is 0.8 meters. These typical ringing values are recommended as the minimum setting for all ADCPs using default set ups.



It should be noted, on some installations the effects of ringing will last longer than the recommended settings above. For example, the effects of ringing will last longer if the transmit signal becomes trapped inside the transducer well. This can occur because the well itself is ringing with the transducer or when windows covering the opening of the well reflect the signal back inside the well.

The window causes the transmit signal to reflect back into the well due to the difference in impedance between the window and the water. When the transmit signal is reflected in the well it becomes trapped and this results in longer ringing periods. To keep from processing this signal, the blanking period must be increased.

Lining the inside walls of the well with a sound absorbing material aid in dampening the ringing effect.

## Acoustic Isolation

Try to minimize the acoustic coupling between the transducer head and the ship. Without adequate acoustic isolation, the transducer output will “ring” throughout the ship and feeds back into the ADCP receive circuits. Ringing causes bias errors in water-track velocities and results in the loss of data in the closest depth cells (bins). Reflections inside a sea chest with an acoustic window also can cause ringing.

You can attain acoustic isolation several ways. At a minimum, use gaskets to isolate all contact points between the ship and the transducer head. Design your installation for:

- A minimum number of contact points between the transducer head and the ship.
- Minimal contact area.
- Single points of contact for positioning and support (when possible).

You also should try to separate the transducer head from the ship using intermediate connections. This is because direct connections transfer the most acoustic energy. Texas A & M used the following installation technique and had minimal ringing problems.

- Transducer mounted to a thin steel plate
- Steel plate positioned with three pins set into mounting holes on the hull; pins isolated with gaskets
- Steel plate held in place with four I-beams welded to a frame
- Frame bolted to another frame and separated by gaskets
- Second frame bolted to the ship and separated by gaskets

Acoustic isolation from other acoustic devices on the ship is also necessary. You can do this using the following techniques.

- Mount the other acoustic devices as far apart as possible.
- Make sure neither the main lobes nor the side lobes of the acoustic devices point at the transducers, including acoustic reflections.
- Try not to operate devices that use the same frequency or a harmonic of the ADCP’s frequency.

## Maintenance

The [Maintenance](#) section explains routine maintenance procedures. You rarely need access to the electronics inside the transducer head. However, one external maintenance item is important enough to mention here as it may affect how you install the transducer head.

Vessel mounted ADCPs are subject to biofouling. Soft-bodied organisms usually cause no problems, but hard barnacle shells can cut through the urethane transducer face causing transducer failure and leakage into the ADCP (see Figure 36).





**Figure 36. Barnacle Damage to Urethane Face**

The best-known way to control biofouling is cleaning the ADCP transducer faces often. However, in many cases this is not possible. The other alternatives include the use of a window or some sort of anti-foulant protection (see [Preventing Biofouling](#)).

## Mariner Deckbox Mounting Considerations

Place the Mariner Deckbox (see [Outline Installation Drawings](#)) where there is access to the I/O cable, host computer, and navigation interface cable. The chassis needs an input voltage of 90 to 260 VAC or 12 VDC to operate (see [Power Considerations](#)). Allow enough room around the Deckbox for access, ventilation, and isolation from electronic and magnetic interference.

## Navigation Interface Considerations

*VmDas* can read in, decode, and record ensembles from an ADCP and NMEA data from some specific (i.e. GPS and attitude sensors) external devices. *VmDas* stores this data in both raw data files (leaving all original data input in its original format) and in a combined, averaged data file. *VmDas* uses all of this data to create different displays for the user.

*VmDas* looks for, and utilizes the following strings if transmitted: standard GGA (position), HDG/HDT (Heading), VTG (speed and track) messages, and a proprietary PRDID (pitch and roll) message.

As well as being able to input NMEA strings to *VmDas*, it can produce NMEA output strings of speed log information. The speed log contains VDVBW (ground/water speed) and VDDBT (depth).



For more information about NMEA data, see the *VmDas* and WinRiver II User's Guides.

## Installation Procedures (Overview)

Read these steps before doing them. In general, follow them in the order listed. Some may differ for your installation, so modify them as necessary. Some can be done simultaneously (e.g., hardware installation and software loading). If you have problems or questions, call us.



The following procedure applies to WorkHorse Mariner ADCPs. Some parts may apply to WorkHorse Monitor/Sentinel ADCPs if they are being mounted to a vessel.

11. On receipt of the system, read the WorkHorse Operation Manual.
12. Before installing the system, test the transducer and Deckbox right out of the shipping container. Do the following.
  - a. All power to the system DISCONNECTED.
  - b. Review [Power Considerations](#).
  - c. Connect the I/O cable from the Deckbox to the ADCP.
  - d. Connect the serial I/O cable from the computer to the Deckbox.
  - e. Connect the power cable to the Deckbox and apply power to the system (the [Routing Cables](#) section shows all cable connections).
  - f. Follow testing procedures in [Testing the WorkHorse](#). Test the system. If errors occur, use [Troubleshooting](#).
13. Prepare the system for shipboard installation. Disconnect all power to the system. Disconnect all interface cables.
14. Review [Transducer Head Mounting Considerations](#). Install the transducer head. Mechanically align the system (see [Alignment Procedures \(Overview\)](#)).



Take steps to prevent leaks through the hull and gate valves.

15. Review section [Mariner Deckbox Mounting Considerations](#). As necessary, install the Deckbox.
16. Review [Computer Considerations](#). Install the computer.
17. Review [Cabling Considerations](#). As necessary, route and connect the following cables:
  - Transducer to Deckbox (J17) interface cable.
  - Navigation to computer cable.



Signals may be present.

18. As necessary, load the software on the computer's hard drive. See the Software User's Guide and the Help files for each program.
19. Configure *VmDas* or *WinRiver II*. See the software's help file and the *VmDas* or *WinRiver II* User's Guide for help on configuring the program.
20. Do the Dock Side Tests (see [Dock Side Tests](#)). If errors occur, use [Troubleshooting](#).
21. Do the Sea Acceptance testing (see [Sea Acceptance Tests](#)). The Sea Acceptance tests include the following checks.
  - Interference
  - Water Profile Range
  - Ringing and (cross-coupling, other pingers, noise)
  - Water Profile Reasonableness (transducer alignment)
  - Bottom-track (range, accuracy)

# Alignment Procedures (Overview)

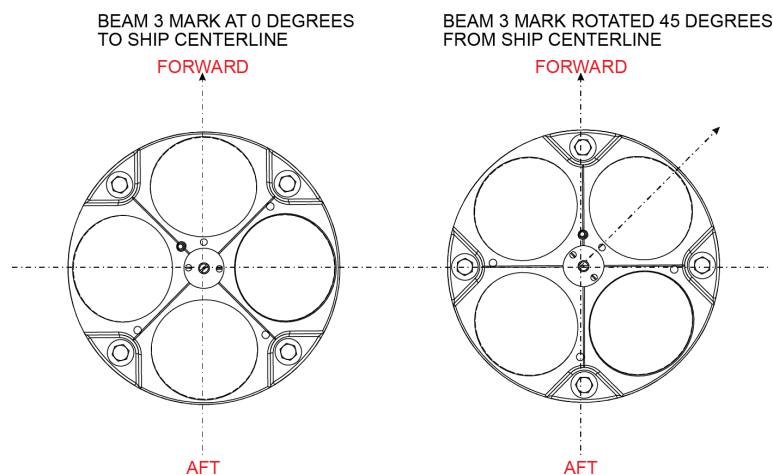


This section does not apply to stationary systems (such as bottom mounted Sentinels). These systems use an internal compass by default.

The mechanical alignment of the transducer head is important to ADCP data accuracy. Mechanically mount the head as close as possible to your reference point. This is usually with the Beam 3 mark at  $0^\circ$  or  $45^\circ$  relative to the ship's fore-to-aft centerline. You also must mount the transducer head as level as possible using the ship's roll and pitch references. Review the [Transducer Head Mounting Considerations](#) for alignment considerations.

*VmDas* uses the **Heading Correction Parameters** on the **Transforms** tab to align the ADCP's north reference (Beam 3 mark) to the north reference of an external compass. Ships use the bow as the north reference.

When the WorkHorse is aboard a vessel, the mechanical alignment of the transducer head (Beam 3 mark) is usually aligned with the ship's fore-to-aft centerline ( $0^\circ$ ) or rotated  $45^\circ$  clockwise. To conceptually determine the misalignment angle, visually hold the ADCP still and turn the ship north reference to match the ADCP's north reference. For example, if the Beam 3 mark is pointing at the bow (Figure 37), the misalignment angle is zero. If the Beam 3 mark is pointing  $45^\circ$  to starboard (Figure 37), you must turn the ship a  $+45^\circ$  to align the two north reference points. Conversely, if the Beam 3 mark is pointing  $45^\circ$  to port, you must turn the ship a  $-45^\circ$  to align the two reference points.



**Figure 37. Transducer Misalignment Reference Points**



The alignment of the transducer installation holes on the Mariner Adapter Plate to the centerline of the transducer is within 0.15 degrees. We recommend you choose a bolt (or stud) that fills the installation holes as close as possible to limit any additional misalignment.

NOTES

# Chapter 3

## COLLECTING DATA



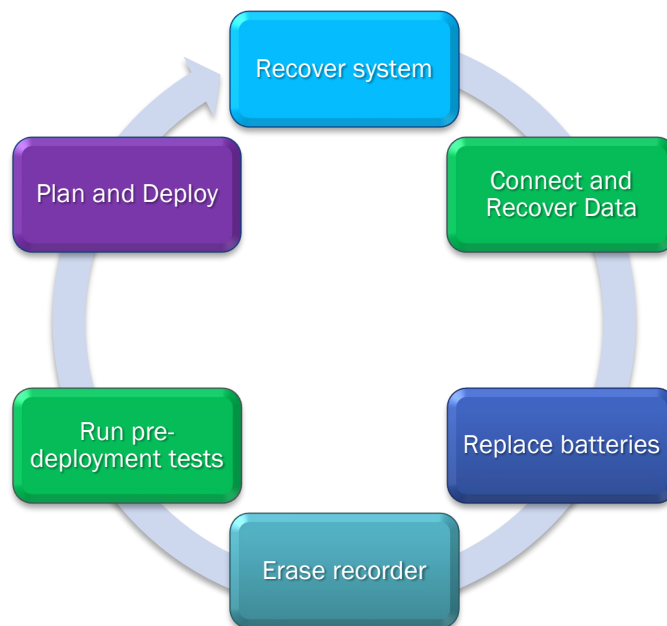
In this chapter, you will learn:

- How to collect Self-Contained data
- How to collect Real-Time data

# Collecting Self-Contained Data

The Self-Contained deployment typical turn-around involves the following tasks:

1. Recover the ADCP to the deck of the support vessel.
2. Connect to the ADCP using *TRDI Toolz*. Download the data to the laptop.
  - It is recommended that all data is downloaded and verified before the CompactFlash recorder is erased.
3. Replace the batteries.
4. Erase the CompactFlash recorder using the RE ErAsE command (this command is case sensitive).
5. Close the self-contained housing and run the pre-deployment tests.
6. Plan the deployment with *PlanADCP* (WH) or *Workhorse II Plan* (WHII) and redeploy the ADCP.



For information on Self-Contained deployments, see the Monitor/Sentinel Deployment Guide and the PlanADCP or Workhorse II Plan help files.



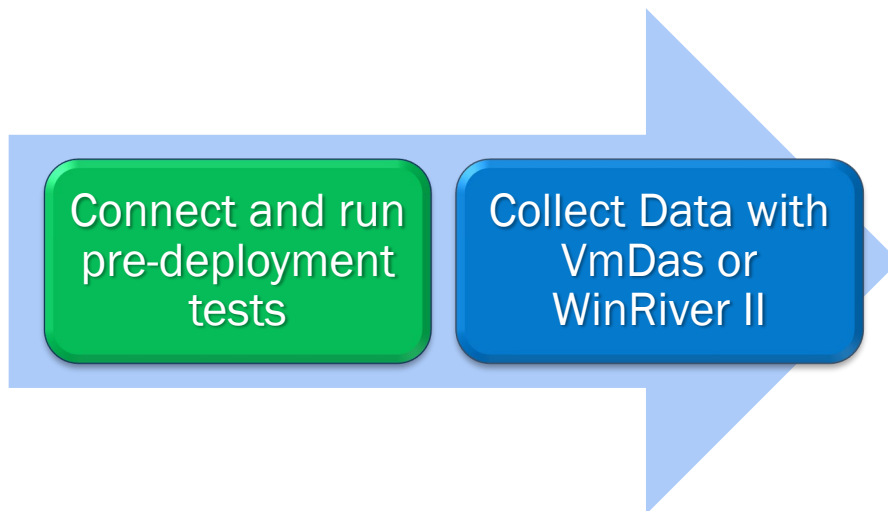
If the system has the Workhorse II electronics installed (firmware version 7x.xx), use the *Workhorse II Plan* software to create a deployment command file.  
If the system has the original Workhorse electronics installed (firmware version 5x.xx), use the *PlanADCP* software to create a deployment command file.

# Collecting Real-Time Data

Workhorse deployments in real time collect, view, and process data collected using the *VmDas* or *WinRiver II* software.

The typical Direct-Reading deployment involves the following tasks:

1. Connect to the ADCP using *TRDI Toolz*. Use *TRDI Toolz* to run the pre-deployment tests.
2. Use *VmDas* or *WinRiver II* to collect data.



All real-time data is collected, viewed, processed, and played back using *VmDas* or *WinRiver II*. No data is recorded to the Workhorse internal recorder. Data is recorded to the computer folder selected in *VmDas* or *WinRiver II*.



See the Mariner Deployment Guide.

For information on *VmDas* or *WinRiver II*, clicking Help in the software will open the software user's guide.



NOTES

# Chapter 4

## MAINTENANCE

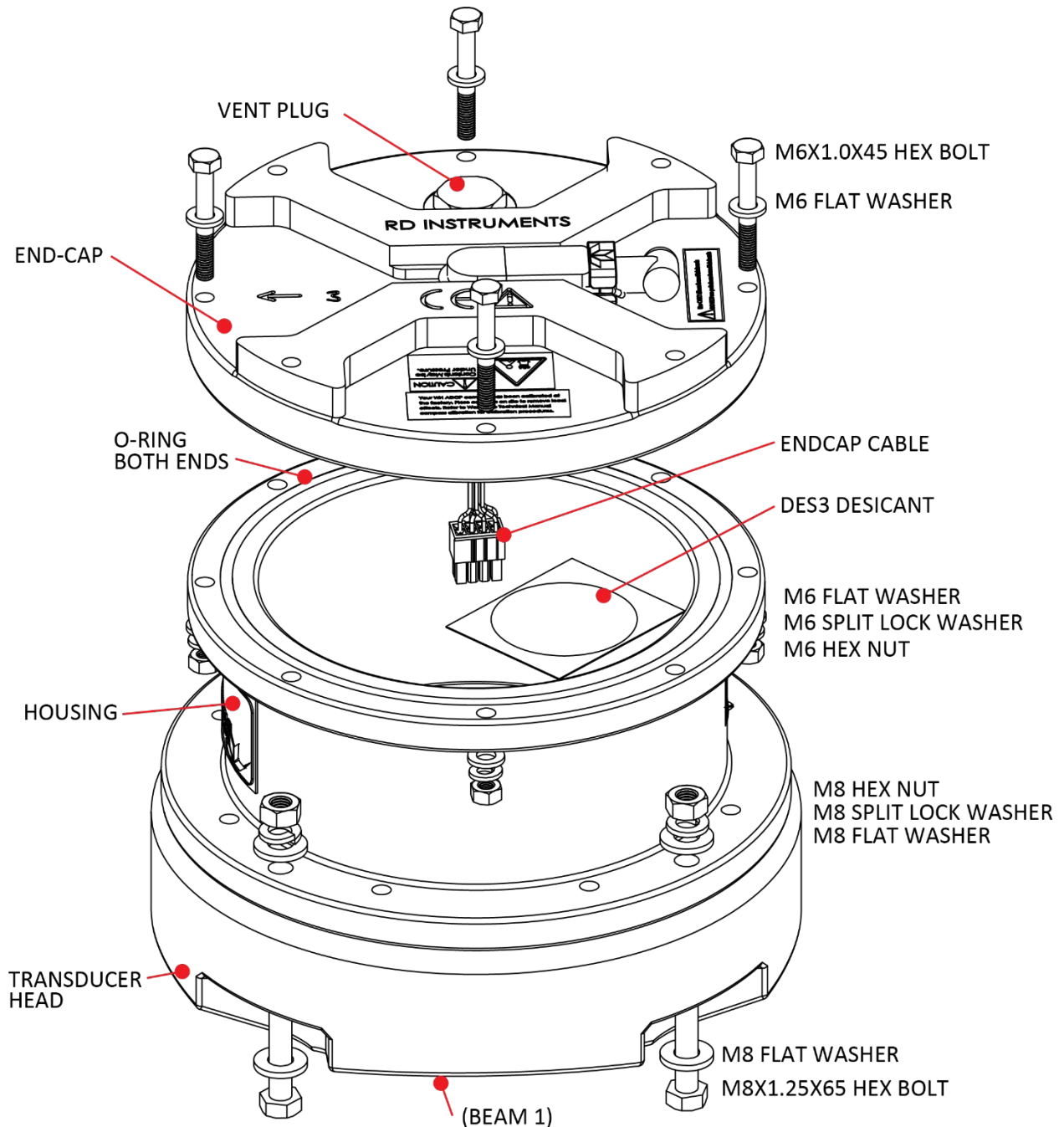


In this chapter, you will learn:

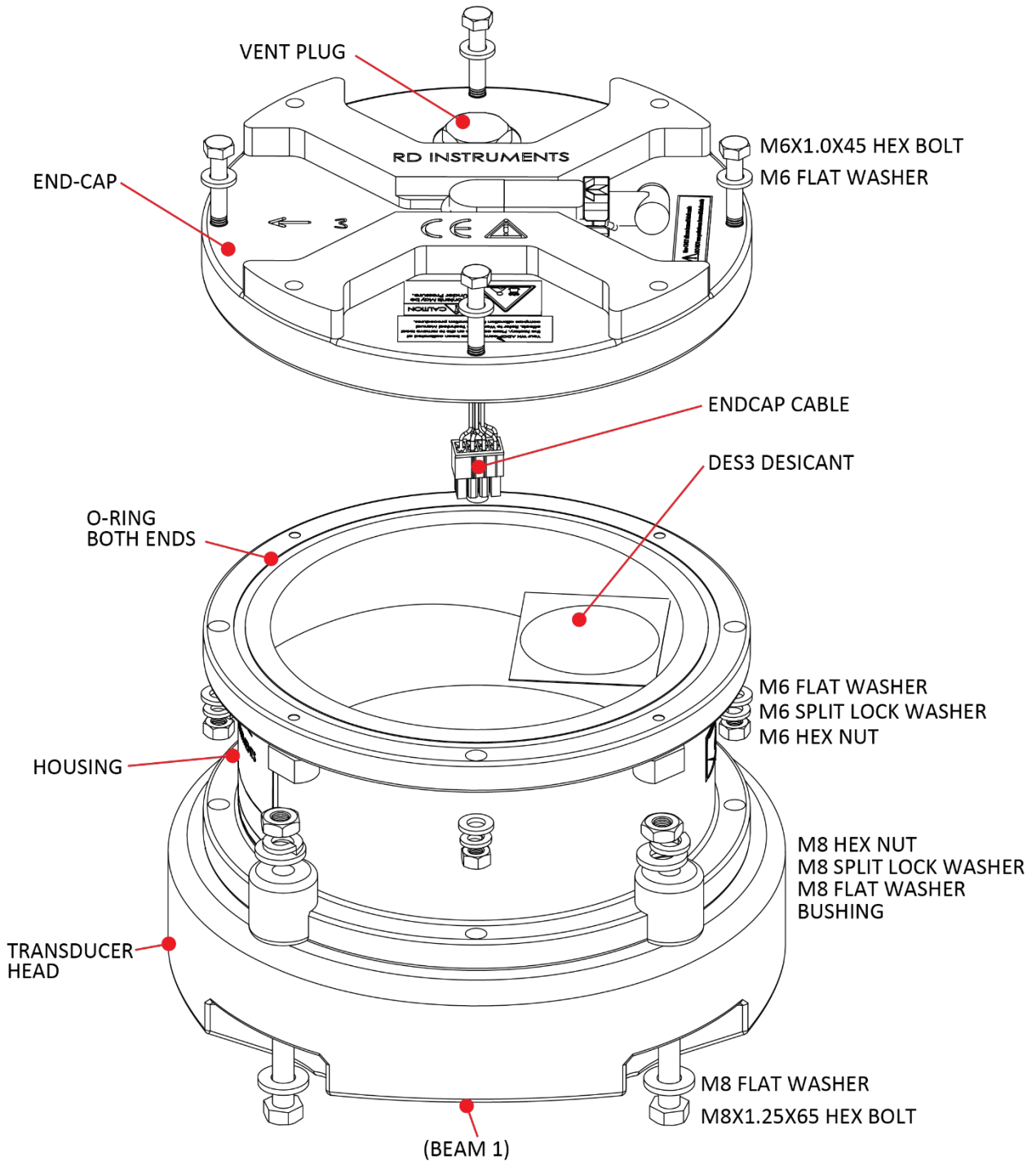
- Where parts are located on the ADCP
- How to spot problems
- How to take the ADCP apart and put it back together
- How to replace the batteries
- How to do periodic maintenance items on the ADCP

# Parts Location Drawings

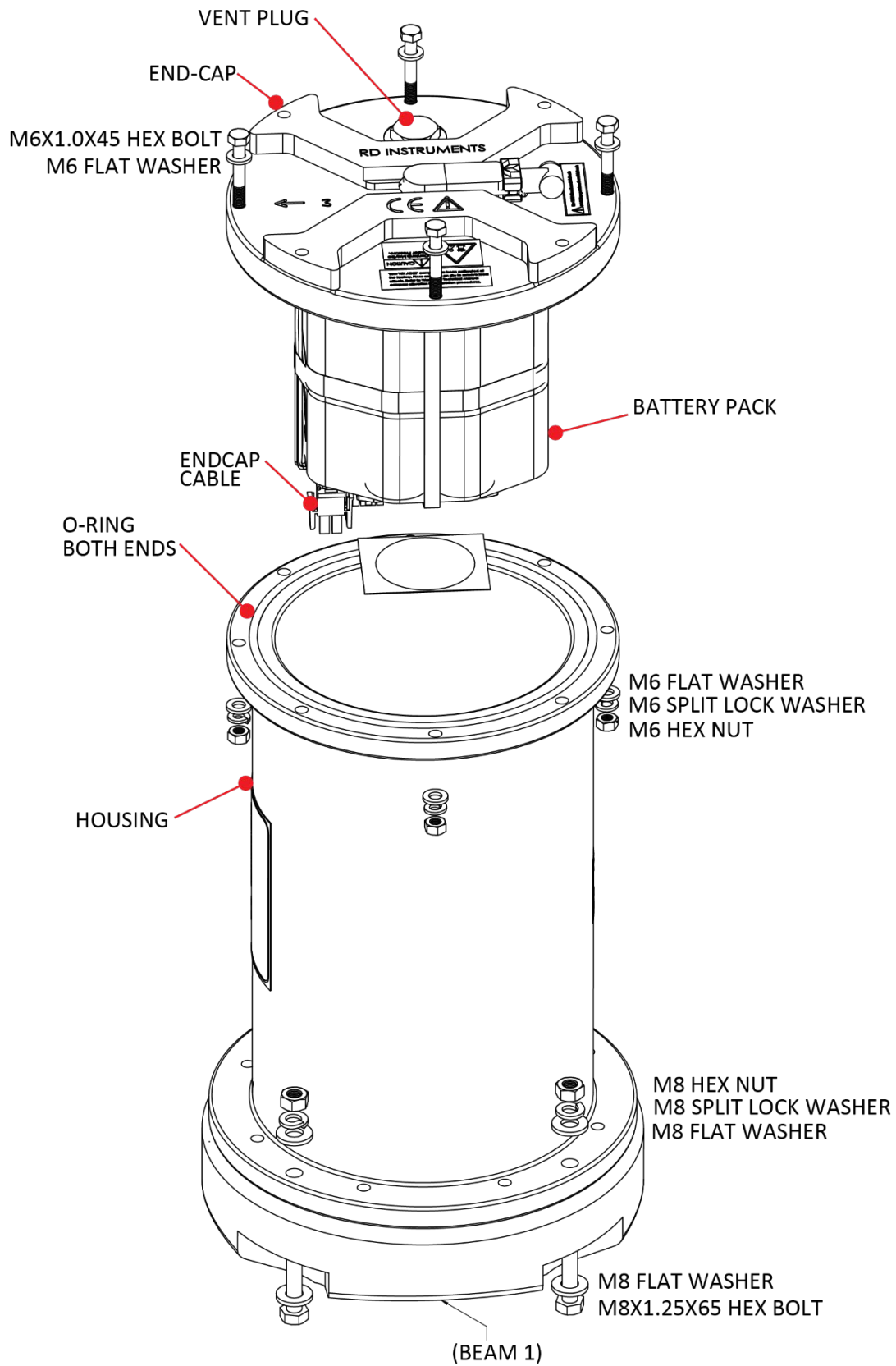
This section is a visual overview of the inside and outside parts of the WorkHorse ADCP. Use the following figures to identify the parts used on your system.



**Figure 38. Mariner/Monitor Parts Location (200 Meter)**



**Figure 39. Mariner/Monitor Parts Location (500 Meter Systems)**



**Figure 40. Sentinel Parts Location (200 Meter Systems)**

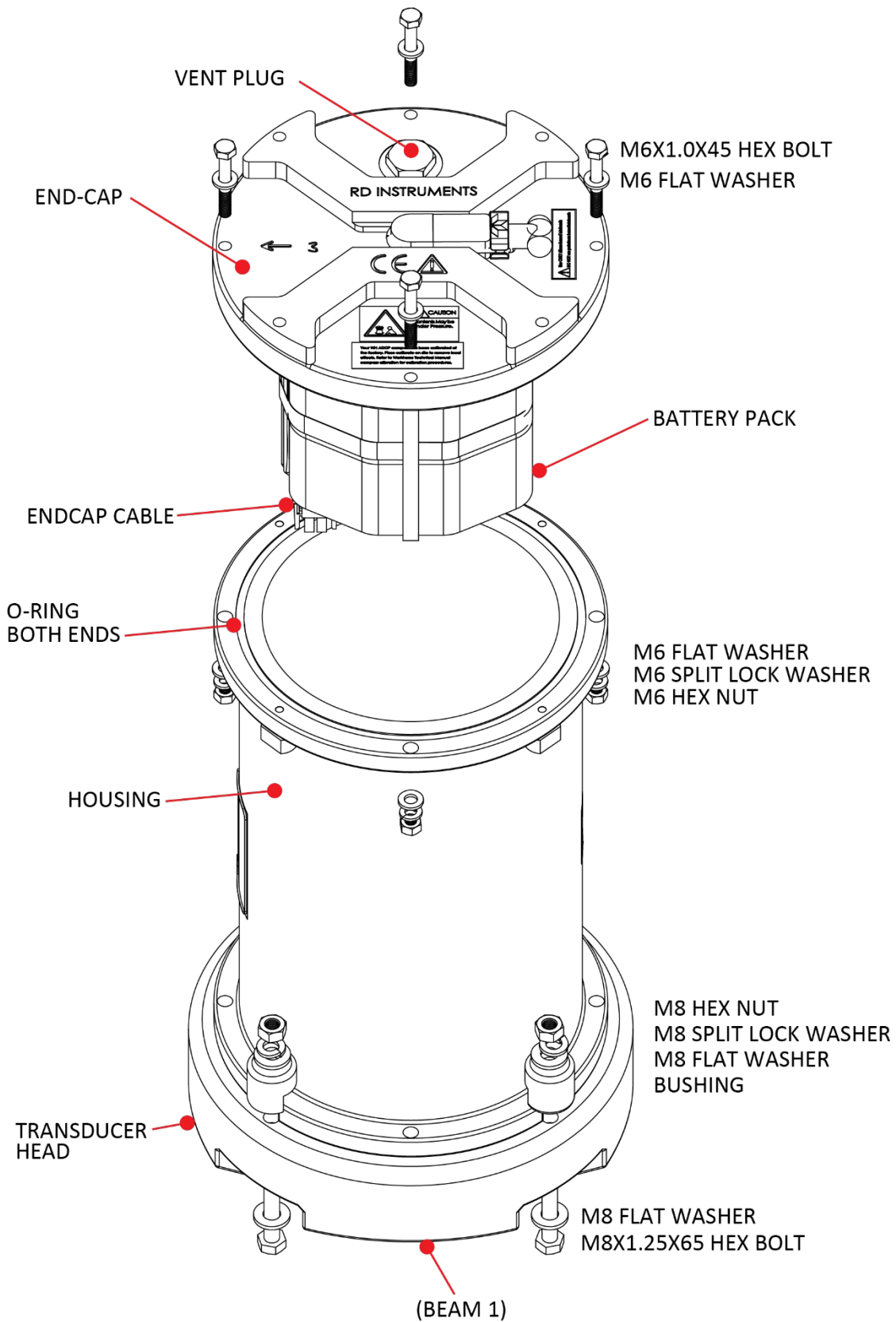
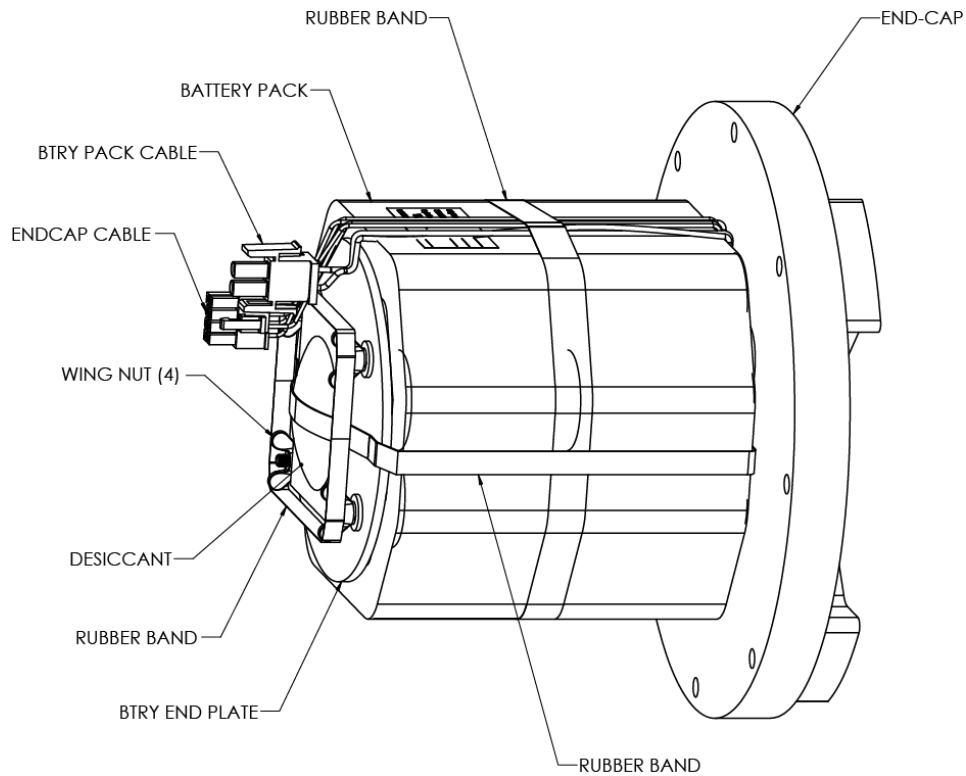


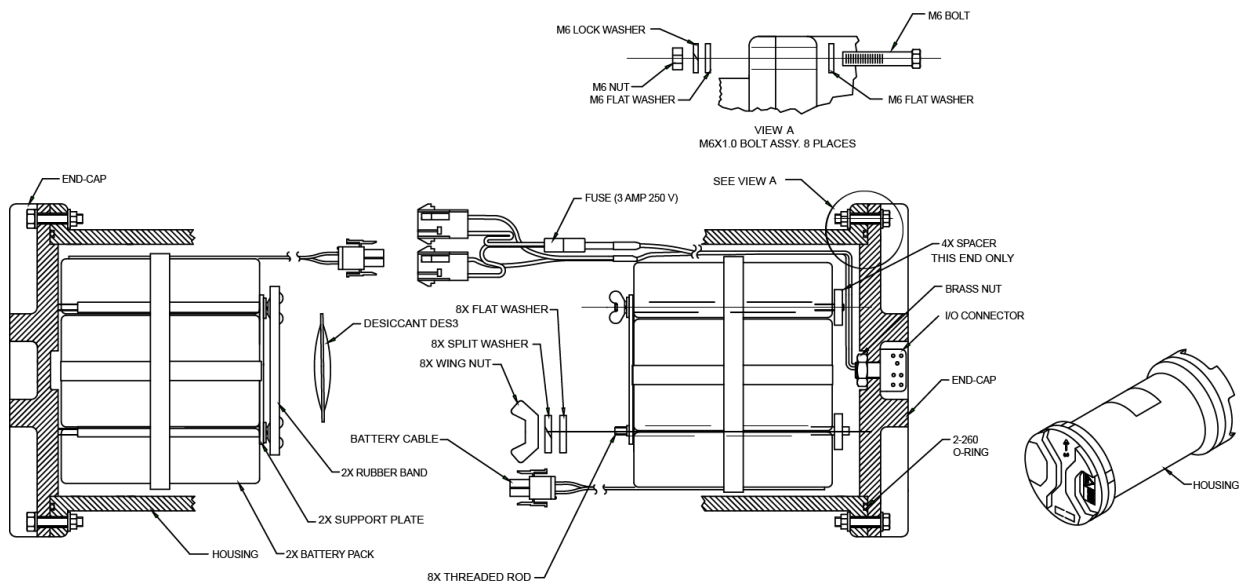
Figure 41. Sentinel Parts Location (500 Meter Systems)



**Figure 42. Sentinel End-cap and Battery Pack Parts Location**



The WorkHorse Sentinel battery packs are held in place by four sets of washers, lock washers, and wing nuts. If the wing nuts are not tight, the assembly of washers and wing nut can become loose and eventually fall onto the PIO board. This has caused the PIO board to short out. Place a rubber band around the four wing nuts to help hold them in place.

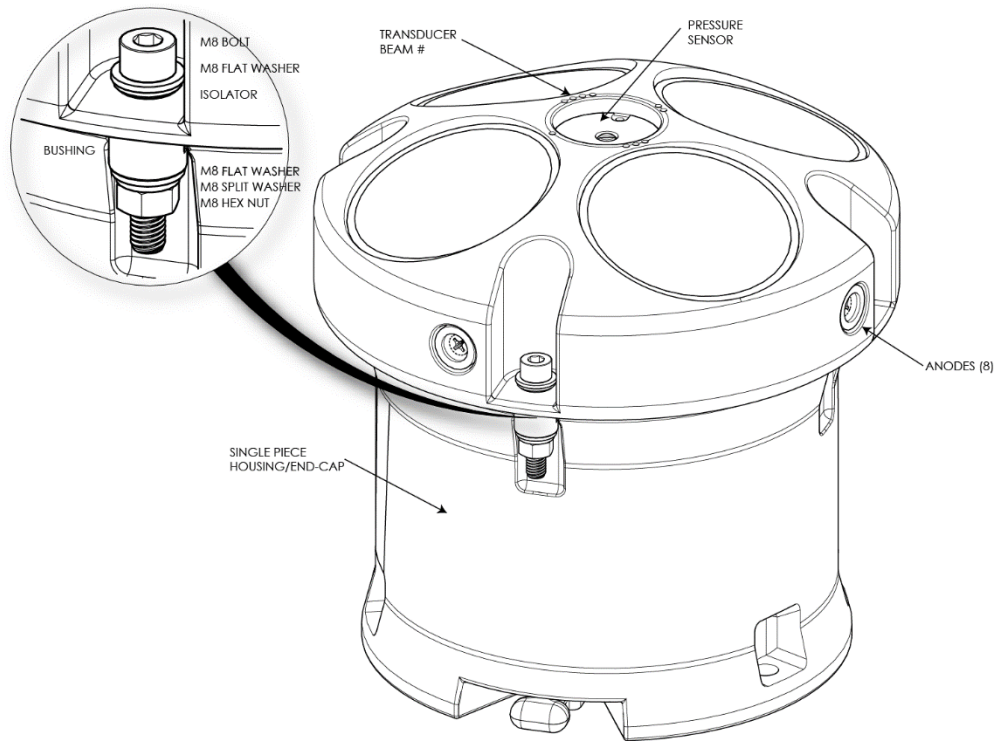


**Figure 43. External Battery Pack Parts Location**

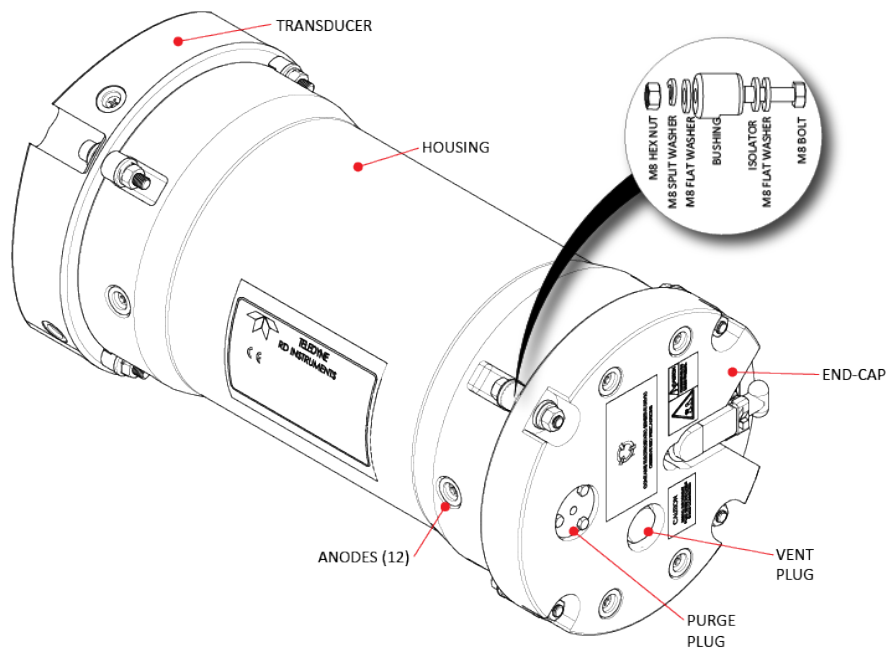


# High-Pressure Parts Location Drawings

Use the following figures to identify parts used on your high-pressure WorkHorse ADCP.



**Figure 44. 6000-meter WorkHorse Monitor Parts Location**



**Figure 45. 6000-meter WorkHorse Sentinel Parts Location**

# Maintenance Schedule

To ensure that you continue to receive optimal results from your Teledyne RD Instruments product(s), TRDI recommends that every ADCP be returned to our factory for an inspection every two to three years. We'll provide your unit with a thorough multi-point inspection, and let you know if any refurbishment services are required to properly maintain the unit. To learn more about this service, please [contact field service](#).

## Calibration Items

Use the following calibration schedule:

Item	TRDI Recommended Period
Transducer Beam Angle Pitch & Roll (Tilt) Temperature (Factory) Pressure Sensor (Factory) Heading (Factory)	TRDI recommends return every two to three years for verification of velocity accuracy
Heading (Field Pre-Deploy)	TRDI recommends return every two to three years for Factory calibration
Heading (Field Post-Deploy)	Field Compass Calibration (AF) performed prior to each deployment (see <a href="#">Compass Calibration</a> ). On WHII systems, use <i>CompassCal</i> software to calibrate an internal compass.
	Field Compass Verification (AX) performed post each deployment (see <a href="#">Compass Calibration Verification</a> ). On WHII systems, use <i>Compass Post Calibration</i> software.



Pressure sensor drift effects will accumulate over time. TRDI recommends a factory calibration be done every two to three years. The longer you wait between factory calibrations, the more error (due to drift) you can expect to have.

For example, the pressure sensor has an initial accuracy spec of  $\pm 0.25\%$ , and a long-term drift spec of  $\pm 0.11\%$ . Most of the 0.11% drift will occur in the first 12 months of operation.

# Maintenance Items

Inspect the ADCP to spot problems:

Item	TRDI Recommended Period
Transducer Beams	<p>The urethane coating is important to ADCP watertight integrity. Many users are not familiar with the early signs of urethane failure. The primary damage to the urethane is from bio-fouling and long exposure to the water and sun. Damage occurs on the surface of the urethane and at the edge where the urethane bonds to the cups. Mishandling, chemicals, abrasive cleaners and excessive depth pressures can also damage the transducer ceramics or urethane coating.</p> <p>Before each deployment, check the urethane coating on the transducer faces for dents, chipping, peeling, urethane shrinkage, hairline cracks and damage that may affect watertight integrity or transducer operation (see Figure 46).</p> <p><b>Based on experience, TRDI knows that most systems need to have the urethane inspected after three to five years of field use; shorter periods may be required depending on marine growth.</b></p>
O-rings	<p>O-rings should be replaced whenever the system is opened and BEFORE they are showing any signs of wear and tear. For example, when replacing the Sentinel battery, the end-cap is removed. Replace the end-cap O-ring each time the end-cap is removed.</p> <p><b>All O-rings should be replaced every one to two years maximum.</b></p> <p>Inspect for damage and replace as needed before each deployment.</p>
Housing and End Cap	<p>Inspect the paint (high pressure systems only) on the end-cap, housing, and transducer assemblies for corrosion, scratches, cracks, abrasions, paint blisters, exposed metal (silver-colored aluminum), exposed anodize (black or dark green), and exposed primer (yellow). <b>Be critical in your judgment; the useful life of the WorkHorse depends on it.</b> See <a href="#">Protective Coating Inspection and Repair</a> for details.</p>
Hardware (bolts, etc.)	<p>Check all bolts, washers and split washers for signs of corrosion before each deployment.</p> <p><b>TRDI recommends replacement after every deployment or every year whichever is longer. Damaged hardware should never be used.</b></p>
Zinc Anodes	<p>Inspect the anodes (available on aluminum systems only) before each deployment for wear around the mounting bolts. Cover bolts with silicone sealant prior to deployment. Replace anodes whenever the mounting bolt is in less than 75% in contact with the bolt. <b>Replace all anodes every one to two years maximum.</b></p>
Purge Plug	<p>The purge plug is included with 3000 meter and greater ADCP systems. This plug is a safety valve and is designed to push out of the system to ensure that there is not excessive pressure inside the system when removing the end cap. <b>Replace the plug O-Rings every 2-3 years.</b></p>
Cables and Connectors	<p>Check the end-cap I/O connector for cracks or bent pins (see Figure 47) before each deployment.</p> <p><b>Replace the end-cap I/O connector every five years as a normal maintenance item (see Table 7. Replacement Kits to order parts).</b></p> <p>Check the cable connectors for cracks or bent pins. Inspect the full length of the cable for cuts, nicks in the insulation, and exposed conductors before each deployment.</p> <p>Check the Deckbox (Mariner) connectors on the rear panel for cracks or bent pins. Repair of the Deckbox connectors should only be done by TRDI.</p>
CPU Lithium Coin-Cell Battery	TRDI recommends <b>replacing the lithium coin-cell battery every five years.</b>



Figure 46. Transducer View



Figure 47. End-Cap View

# Spare Parts

Periodic maintenance helps maintain the ADCP so it is ready for a deployment. Use the following tables if you need to order replacement parts.

**Table 5: WorkHorse 200 and 500 meters Spare Parts**

Part Number	Item Name	Where Used
SPR84-1LB	Rubber Band	Battery pack to hold desiccant in place
5020	Silicone Lubricant, 4-Pack	Housing
97Z-6052-00	O-Ring, 2-260 (200 meter housing)	
97Z-6053-00	O-Ring, 2-261 (500 meter housing)	
M10COMBINATION	Wrench, 10MM COMB.	
M13COMBINATION	Wrench, 13MM COMB.	
M6WASHSPLTI	Washer, 6MM Split Lock, Titanium	
M6WASHSTDTI	Washer, Flat, Titanium 12.5MM OD	
M6X1.0NUTTI	Nut, Hex, Titanium 10MM	
M6X1.0X45HHTI	Screw, Hex Head, Titanium	
M8WASHSPLTI	Washer, Split Lock, Titanium	
M8WASHSTDTI	Washer, Flat, Titanium 22.9MM OD	
M8X1.25NUTTI	Nut, Hex, Titanium 13MM	
M8X1.25X65HHTI	Screw, Hex Head, Titanium Full Threads Length	
75ZK6001-00	Kit, Clip, Cable	
75ZK6001-01	Kit, Clip, Dummy Plug	
GMA-3A	Fuse, 5MM X 20MM 3R 250V	Main Electronics
DES3	Desiccant, Sealed Bag	Inside Housing
817-1067-00	Screw, Pressure Sensor	Pressure Sensor

**Table 6: High-Pressure Systems Spare Parts**

Part Number	Item Name	Where Used
SPR84-1LB	Rubber Band	Battery pack
5020	Silicone Lubricant, 4-Pack	Housing
97Z-6008-00	O-Ring, 2-013, DURO 70, EPDM	
8-013 N300-90	O-Ring, purge plug, backup (6000m only)	
97Z-6050-00	O-Ring, 2-258, 70 DURO, EPDM	
97Z-6053-00	O-Ring, 2-261 DURO 70, EDPM	
97Z-6068-00	O-Ring, Back-Up Ring Bore Seal, DURO 90	
M13COMBINATION	Wrench, 13mm Comb.	
7289A16	Key, Hex, 5m	
7289A17	Key, Hex, 6m	
811-4007-00	Bushing	
305D0010	Isolator	
M8WASHSPL	Washer, Split Lock,SST316	
M8WASHSTD	Washer, Flat16mmmod,SST316	
M8X1.25NUT	Nut, Hex, SST316	
M8X1.25X45SH	Screw, SKT HD.SST 316	
810-4006-00	ANODE, Housing FLANGE, 3000/6000M	
RTV162	Sealant, Silicone 2.8 OZ	
75ZK6001-00	Kit, Clip, Cable	
75ZK6001-01	Kit, Clip, Dummy Plug	
GMA-3A	Fuse, 5mm X 20mm 3R 250V	
DES3	Desiccant, Sealed Bag	Inside Housing
817-1067-00	Screw, Pressure Sensor	Pressure Sensor

**Table 7. Replacement Kits**

Part Number	Description	Where Used
757K6122-00	WorkHorse End-Cap Tools Kit	<a href="#">Replacing the End Cap Connector</a>
757K6123-00 (200 and 500 meter systems)	End Cap Connector Replacement Kit (requires the WorkHorse End-Cap Tools Kit)	
757K6125-00 (6000 meter systems)		
757K6149-00 (WorkHorse External Battery case)		
757K6023-00	WorkHorse Sentinel Battery Pack Kit (includes 1 battery, desiccant, and 2 rubber bands)	<a href="#">Replacing the Sentinel Battery Packs</a>
717-3009-00	WorkHorse Sentinel Battery Packs (10-pack)	<a href="#">Replacing the External Battery Case Packs</a>
757K6152-00	Anode Kit, 500 Meter WorkHorse	<a href="#">Zinc Anode Inspection and Replacement</a>
707-2038-12	KIT, UPGRADE, ISM, MAIN ELEC, ASSY, 1200KHZ, WH-II	<a href="#">Installing the Spare Boards Kit</a>
707-2038-13	KIT, UPGRADE, ISM, MAIN ELEC, ASSY, 600KHZ, WH-II	
707-2038-14	KIT, UPGRADE, ISM, MAIN ELEC, ASSY, 300KHZ, WH-II	
757K6037-00	WorkHorse 200 meter Monitor/Sentinel Spare Parts Kit	Replacement spare parts kit (see Table 5 and Table 6 for list of included parts).
757K6068-00	WorkHorse 500 meter Monitor/Sentinel Spare Parts Kit	
757K6057-00	WorkHorse Mariner Spare Parts Kit	
757K6072-00	WorkHorse 6000 meter Monitor/Sentinel Spare Parts Kit	
757K6036-00	WorkHorse 200 meter Close-up kit	Includes needed hardware, O-rings, and desiccant to seal the ADCP.
757K6069-00	WorkHorse 500 meter Close-up kit	
757K6113-00	WorkHorse Mariner Close-up kit	
757K6011-00	WorkHorse 6000 meter Close-up kit	

# Disassembly and Assembly Procedures

This section explains how to remove and replace the end-cap or transducer head to gain access to the ADCP's electronics, batteries, and internal recorder. Read all instructions before doing the required actions.

Standard 200 meter and 500 meter housings

- [End-Cap Removal Procedures](#)
- [Transducer Head Assembly Removal](#)
- [O-ring Inspection and Replacement](#)
- [End-cap Replacement](#)
- [Transducer Head Replacement](#)

High Pressure systems

- [High-Pressure End-Cap Removal Procedures](#)
- [High-Pressure Transducer Head Assembly Removal](#)
- [High-Pressure O-ring Inspection and Replacement](#)
- [High-Pressure End-cap Replacement](#)
- [High-Pressure Transducer Head Replacement](#)



# End-Cap Removal Procedures



Caution label on End-Cap



Wear safety glasses and keep head and body clear of the end-cap while opening.  
Any system that was deployed may have pressure inside the housing.



When you need access to the electronics, TRDI recommends removing the transducer head assembly (see [Transducer Head Assembly Removal](#)).  
Use [Parts Location Drawings](#) for parts identification.

To remove the end-cap:

1. Dry the outside of the ADCP.
2. Disconnect the I/O cable and install the dummy plug.
3. Stand the ADCP on its transducer faces on a soft pad.
4. Inspect the housing and end cap bolts for any signs of damage such as bending, stretched bolts, crushed or deformed bushings, etc. These signs may indicate that there is internal pressure inside the system.
5. To avoid any possible injury it is ALWAYS recommended to vent the system:  
Use the Vent Plug to vent the system before opening the housing. Loosen the port 1/2 turn and listen for airflow; if none, then open another 1/2 turn and listen again for airflow. Repeat until the Vent Plug is fully removed. This will ensure no internal pressure is present when removing the housing.  
If the system does not have a Vent Plug, loosen but do not remove the four transducer bolts to allow any internal pressure to be vented from the system. **Loosen the transducer bolts two turns each in a cross-pattern. Repeat until the face seal O-ring is not compressed and the system has the opportunity to vent.** If you note that the transducer moves as you loosen the bolts then this may indicate that internal pressure is present. Be sure to only loosen the bolts far enough to allow the system to vent.
6. Once all four end-cap bolts have been loosened and you are sure that there is no internal pressure, remove the bolts from the end-cap.



Make sure you save all hardware removed during this procedure for re-assembly.

7. Carefully pull the end-cap away from the housing until you can gain access to the connector jack on the common mode choke. Use care; the plastic mating surfaces scratch easily. Do not damage the mating surfaces.
8. Squeeze the sides of the internal I/O cable connector to release it from the common mode choke jack. Set the end-cap aside.
9. Clean the O-ring mating surfaces with a soft, lint-free cloth. Inspect the surfaces for damage (see [O-ring Inspection and Replacement](#)). Even small scratches can cause leakage around the O-ring seal.

# Transducer Head Assembly Removal



When you need access to the Sentinel internal battery, remove the end-cap assembly (see [End-Cap Removal Procedures](#)).

1. Remove all power to the WorkHorse.
2. Remove the I/O cable and place the dummy plug on the I/O cable connector (see [I/O Cable and Dummy Plug](#)).
3. Stand the WorkHorse on its end-cap.



Wear safety glasses and keep head and body clear of the transducer while opening.  
Any system that was deployed may have pressure inside the housing.

4. Inspect the transducer bolts for any signs of damage such as bending, stretched bolts, crushed or deformed bushings, etc. These signs may indicate that there is internal pressure inside the system.
5. To avoid any possible injury it is ALWAYS recommended to vent the system:

Use the Vent Plug to vent the system before opening the housing. Loosen the port 1/2 turn and listen for airflow; if none, then open another 1/2 turn and listen again for airflow. Repeat until the Vent Plug is fully removed. This will ensure no internal pressure is present when removing the housing.

If the system does not have a Vent Plug, loosen but do not remove the four transducer bolts to allow any internal pressure to be vented from the system. **Loosen the transducer bolts two turns each in a cross-pattern. Repeat until the face seal O-ring is not compressed and the system has the opportunity to vent.** If you note that the transducer moves as you loosen the bolts then this may indicate that internal pressure is present. Be sure to only loosen the bolts far enough to allow the system to vent.

6. Once all four bolts have been loosened and you are sure that there is no internal pressure, remove the bolts from the transducer.
7. Carefully lift the transducer assembly straight up and away from the housing until you can gain access to the connector jack on the common mode choke. Use care; the plastic mating surfaces scratch easily. Do not damage the mating surfaces.



The cable attached to the end cap is only long enough to disconnect the internal I/O cable. There is NOT enough cable to set the transducer down next to the Housing Assembly.

8. Squeeze the sides of the internal I/O cable connector to release it from the common mode choke jack. Set the end-cap assembly aside. Set the transducer assembly (transducer face down) on a soft pad.
9. Clean the O-ring mating surfaces with a soft, lint-free cloth. Inspect the surfaces for damage (see [O-ring Inspection and Replacement](#)).
10. When you are ready to re-assemble the WorkHorse, see [WorkHorse Re-assembly](#).

## WorkHorse Re-assembly

To replace the end-cap and transducer head, proceed as follows. Use [Parts Location Drawings](#) for parts identification.

1. If you are sealing the WorkHorse for a deployment, be sure you have done all appropriate maintenance items (see [Sealing the WorkHorse for a Deployment](#)).
2. Make sure all printed circuit boards, spacers, cables, and screws have been installed.
3. Install two fresh bags of desiccant just before closing the WorkHorse (see [Desiccant Bags](#)).

## O-ring Inspection and Replacement

This section explains how to inspect/replace the WorkHorse O-rings. A successful deployment depends on the condition of two O-rings and their retaining grooves. See [Parts Location Drawings](#) for the locations of the following O-rings. Read all instructions before doing the required actions.

### 200-meter housings

- Transducer assembly, face, 2-260
- End-cap assembly, face, 2-260

### 500-meter housings

- Transducer assembly, face, 2-261
- End-cap assembly, face, 2-261

### Vent Plug

- 97Z-6084-00 O-RING, 2-015, .070DIAX .551 ID, EPDM, DURO 90A, VENT PLUG
- 97Z-6084-01 O-RING, 3-904, .072DIAX .351 ID, EPDM, DURO90A, VENT PLUG

TRDI strongly recommends replacing these O-rings whenever you disassemble the WorkHorse. Inspecting and replacing the O-rings should be the last maintenance task done before sealing the WorkHorse.



TRDI recommends you use new O-rings if you are preparing for a deployment.

To replace the O-Ring:

1. Inspect the O-rings. When viewed with an unaided eye, the O-rings must be free of cuts, indentations, abrasions, foreign matter, and flow marks. The O-ring must be smooth and uniform in appearance. Defects must be less than 0.1 mm (0.004 in.).



If the O-ring appears compressed from prior use, replace it. Weak or damaged O-rings will cause the ADCP to flood.

2. Clean and inspect the O-ring grooves. Be sure the grooves are free of foreign matter, scratches, indentations, corrosion, and pitting. Run your fingernail across damaged areas. If you cannot feel the defect, the damage may be minor; otherwise, the damage may need repair.



Check the O-ring groove thoroughly. Any foreign matter in the O-ring groove will cause the ADCP to flood.

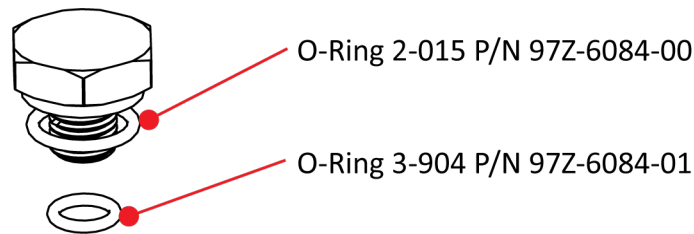
3. If a scratch is on the plastic housing flange O-ring groove, it may be gently sanded using 600-grit (wet) sandpaper. Use care not to cause further damage.

- Lubricate the O-ring with a thin coat of silicone lubricant (Table 5, item 5). Apply the lubricant using latex gloves. Do not let loose fibers or lint stick to the O-ring. Fibers can provide a leakage path.



Apply a very thin coat of silicone lube on the O-ring. Using too much silicone lube on the O-ring can be more harmful than using no O-ring lube at all.

- Lubricate and inspect the Vent Plug O-rings. Place the lower Vent Plug O-ring so that it rests on the bottom of the vent plug hole. Check the face Vent Plug O-ring is in the groove on the plug.
- Install the Vent plug until “finger-tight.”
- Tighten the Vent Plug to the recommended torque value of 6.8 Newton-meters (60 pound-inches).



Tighten the Vent Plug to the recommended torque value of 6.8 Newton-meters (60 pound-inches).

## End-Cap Replacement

To replace the end-cap:

- Stand the WorkHorse on its transducer face on a soft pad.
- Inspect, clean, and lubricate the O-ring on the housing (see [O-ring Inspection and Replacement](#)). Apply a very thin coat of silicone lube on the O-ring.



TRDI recommends you use new O-rings if you are preparing for a deployment.



Apply a very thin coat of silicone lube on the O-ring. Using too much silicone lube on the O-ring can be more harmful than using no O-ring lube at all.

- Connect the internal I/O connector to the plug on the common mode choke.
- Place the end-cap on the housing, aligning the mating holes and the beam 3 number embossed on the end-cap with the beam 3 number embossed on the transducer head. When mating the end-cap

with the housing flange, try to apply equal pressure to all parts of the O-rings. Make sure the face O-ring remains in its retaining groove.



Check that no wires or any other object is pinched between the end-cap and the housing. Use rubber bands to hold the wiring in place as necessary. If the O-ring is not in the groove or if a wire or other object is pinched, the ADCP will flood.

5. Examine the titanium end-cap assembly nuts, bolts, and washers (6-mm) for corrosion; replace if necessary. The [Parts Location Drawings](#) shows the assembly order of the end-cap mounting hardware. All the hardware items are needed to seal the WorkHorse properly.
6. Install all four sets of hardware until “finger-tight.”
7. Tighten the bolts in small increments in a “cross” pattern until the split washer flattens out, and then tighten each bolt ¼ turn more to compress the face seal O-ring evenly. Tighten the bolts to the recommended torque value of 5.6 Newton-meters (50 pound-inches).



Apply equal pressure to the O-ring as you tighten the bolts. If one bolt is tightened more than the others, the O-ring can become pinched or torn. A damaged O-ring will cause the system to flood.



Do not over tighten the bolts that hold the transducer, housing, and end cap together. If you tighten too far, you can crack or break the plastic housing. On the other hand, leaving the bolts too loose can cause the system to flood. Tighten the hardware to the recommended torque value.



The recommended torque value for the end-cap 6-mm bolts is 5.6 Newton-meters (50 pound-inches).

## Transducer Head Assembly Replacement

To replace the transducer head:

1. Stand the WorkHorse on its end-cap.
2. Inspect, clean, and lubricate the O-ring on the housing (see [O-ring Inspection and Replacement](#)). Apply a very thin coat of silicone lube on the O-ring.



TRDI recommends you use new O-rings if you are preparing for a deployment.



Apply a very thin coat of silicone lube on the O-ring. Using too much silicone lube on the O-ring can be more harmful than using no O-ring lube at all.

3. Connect the internal I/O connector to the plug on the common mode choke.
4. Gently lower the transducer head/electronics assembly into the housing, aligning the mating holes and the beam 3 number embossed on the transducer head with the beam 3 number embossed on the end-cap. When mating the housing with the transducer head flange try to apply equal pressure to all parts of the O-ring. Make sure the face O-ring remains in the retaining groove.



Check that no wires or any other object is pinched between the transducer head assembly and the housing. Use rubber bands to hold the wiring in place as necessary. If the O-ring is not in the groove or if a wire or other object is pinched, the ADCP will flood.

5. Examine the titanium transducer assembly nuts, bolts, and washers (8-mm) for corrosion; replace if necessary. The [Parts Location Drawings](#) shows the assembly order of the transducer mounting hardware. All hardware items are needed to seal the WorkHorse properly.
6. Install all four sets of hardware until “finger tight.”
7. Tighten the bolts in small increments in a “cross” pattern until the split washer flattens out, and then tighten each bolt ¼ turn more to compress the face seal O-ring evenly. Tighten the bolts to the recommended torque value of 9.6 Newton-meters (85 pound-inches). Do not deform the plastic bushings.



Apply equal pressure to the O-ring as you tighten the bolts. If one bolt is tightened more than the others, the O-ring can become pinched or torn. A damaged O-ring will cause the system to flood.



Do not over tighten the bolts that hold the transducer, housing, and end cap together. If you tighten too far, you can crack or break the plastic housing. On the other hand, leaving the bolts too loose can cause the system to flood. Tighten the hardware to the recommended torque value.



The recommended torque value for the transducer head 8-mm bolts is 9.6 Newton-meters (85 pound-inches).

## High Pressure Housings

The high pressure housing upgrade allows you to deploy the ADCP in depths up to 6000 meters. The [Outline Installation Drawings](#) shows the dimensions and weights for all of the systems.

This section includes information on installation, removal, and maintenance items for the high-pressure housing only.

## High-Pressure Housing Disassembly

This section explains how to remove and replace the high-pressure end-cap or transducer head to gain access to the ADCP’s electronics, batteries, and internal recorder. Read all instructions before doing the required actions.

### High-Pressure End-Cap Removal Procedures



Caution label on End-Cap



Wear safety glasses and keep head and body clear of the end-cap while opening. Any system that was deployed may have pressure inside the housing.



When you need access to the electronics, TRDI recommends removing the transducer head assembly (see [High-Pressure End-Cap Removal Procedures](#)).



The Monitor 6000 meter housing is one piece. Follow the [High-Pressure Transducer Head Assembly Removal](#) to remove the housing. Use [High-Pressure Parts Location Drawings](#) for parts identification.

To remove the end-cap:

1. Dry the outside of the ADCP.
2. Disconnect the I/O cable and install the dummy plug.
3. Stand the ADCP on its transducer faces on a soft pad.
4. Inspect the housing and end cap bolts for any signs of damage such as bending, stretched bolts, crushed or deformed bushings, etc. These signs may indicate that there is internal pressure inside the system.
5. To avoid any possible injury it is ALWAYS recommended to vent the system:  
Use the Vent Plug to vent the system before opening the housing. Loosen the port 1/2 turn and listen for airflow; if none, then open another 1/2 turn and listen again for airflow. Repeat until the Vent Plug is fully removed. This will ensure no internal pressure is present when removing the housing.  
If the system does not have a Vent Plug, loosen but do not remove the four transducer bolts to allow any internal pressure to be vented from the system. **Loosen the transducer bolts two turns each in a cross-pattern. Repeat until the face seal O-ring is not compressed and the system has the opportunity to vent.** If you note that the transducer moves as you loosen the bolts then this may indicate that internal pressure is present. Be sure to only loosen the bolts far enough to allow the system to vent.
6. Once all four end-cap bolts have been loosened and you are sure that there is no internal pressure, remove the bolts from the end-cap.



Make sure you save all hardware removed during this procedure for re-assembly.

7. Carefully pull the end-cap away from the housing until you can gain access to the connector jack on the common mode choke. Use care; the plastic mating surfaces scratch easily. Do not damage the mating surfaces.
8. Squeeze the sides of the internal I/O cable connector to release it from the common mode choke jack. Set the end-cap aside.
9. Remove any water from the end-cap O-ring grooves with a soft, lint-free cloth. Clean the O-ring mating surfaces. Inspect the surfaces for damage. Even small scratches can cause leakage around the O-ring seal.

## High-Pressure Transducer Head Assembly Removal


1. Remove all power to the WorkHorse.
2. Remove the I/O cable and place the dummy plug on the I/O cable connector (see [I/O Cable and Dummy Plug](#)).
3. Stand the WorkHorse on its end-cap.



Wear safety glasses and keep head and body clear of the end-cap while opening.  
Any system that was deployed may have pressure inside the housing.

4. Inspect the transducer bolts for any signs of damage such as bending, stretched bolts, crushed or deformed bushings, etc. These signs may indicate that there is internal pressure inside the system.



5. To avoid any possible injury it is ALWAYS recommended to vent the system:  
Use the Vent Plug to vent the system before opening the housing. Loosen the port 1/2 turn and listen for airflow; if none, then open another 1/2 turn and listen again for airflow. Repeat until the Vent Plug is fully removed. This will ensure no internal pressure is present when removing the housing.  
If the system does not have a Vent Plug, loosen but do not remove the four transducer bolts to allow any internal pressure to be vented from the system. **Loosen the transducer bolts two turns each in a cross-pattern. Repeat until the face seal O-ring is not compressed and the system has the opportunity to vent.** If you note that the transducer moves as you loosen the bolts then this may indicate that internal pressure is present. Be sure to only loosen the bolts far enough to allow the system to vent.
  6. Once all four bolts have been loosened and you are sure that there is no internal pressure, remove the bolts from the transducer.
  7. Carefully lift the transducer assembly straight up and away from the housing until you can gain access to the connector jack on the common mode choke. Use care; the plastic mating surfaces scratch easily. Do not damage the mating surfaces.
- 

The cable attached to the end cap is only long enough to disconnect the internal I/O cable. There is NOT enough cable to set the transducer down next to the Housing Assembly.
8. Squeeze the sides of the internal I/O cable connector to release it from the common mode choke jack. Set the end-cap assembly aside. Set the transducer assembly (transducer face down) on a soft pad.
  9. Clean the O-ring mating surfaces with a soft, lint-free cloth. Inspect the surfaces for damage.
  10. When you are ready to re-assemble the WorkHorse, see [High-Pressure WorkHorse Re-assembly](#).

## High-Pressure WorkHorse Re-assembly

Use the [High-Pressure Parts Location Drawings](#) for parts identification.

1. If you are sealing the WorkHorse for a deployment, be sure you have done all appropriate maintenance items (see [Sealing the WorkHorse for a Deployment](#)).
2. Make sure all printed circuit boards, spacers, cables, and screws have been installed.
3. Install two fresh bags of desiccant just before closing the WorkHorse (see [Desiccant Bags](#)).

## High-Pressure O-Ring Inspection & Replacement

This section explains how to inspect/replace the WorkHorse O-rings. A successful deployment depends on the condition of two O-rings and their retaining grooves. See [High-Pressure Parts Location Drawings](#) for the locations of the following O-rings. Read all instructions before doing the required actions.

### 1000-, 3000-, and 6000-meter high-pressure housings

- Transducer and end-cap assembly, bore 2-258
- Transducer and end-cap assembly, face 2-261
- Transducer and end-cap assembly, backup O-ring, 8-258 N300-90

### Systems with a 97Z-4000-00 Vent Plug

- 97Z-6084-00 O-RING, 2-015, .070DIAX .551 ID, EPDM, DURO 90A, VENT PLUG
- 97Z-6084-01 O-RING, 3-904, .072DIAX .351 ID, EPDM, DURO90A, VENT PLUG



The backup O-ring is installed on 1000, 3000, and 6000 meter high-pressure housing systems in addition to the 2-258 bore O-ring on the transducer head and end-cap assembly. Install the backup O-ring with the cupped side facing the 2-258 bore seal O-ring as shown in Figure 48.



TRDI strongly recommends replacing these O-rings whenever you disassemble the WorkHorse. Inspecting and replacing the O-rings should be the last maintenance task done before sealing the WorkHorse.

To replace the O-rings:

1. Inspect the O-rings. When viewed with an unaided eye, the O-rings must be free of cuts, indentations, abrasions, foreign matter, and flow marks. The O-ring must be smooth and uniform in appearance. Defects must be less than 0.1 mm (0.004 in.).



If the O-ring appears compressed from prior use, replace it. Weak or damaged O-rings will cause the ADCP to flood.

2. Clean and inspect the O-ring grooves. Be sure the grooves are free of foreign matter, scratches, indentations, corrosion, and pitting. Run your fingernail across damaged areas. If you cannot feel the defect, the damage may be minor; otherwise, the damage may need repair.



Check the O-ring grooves thoroughly. Any foreign matter in the O-ring grooves will cause the ADCP to flood.

3. Lubricate the O-ring with a thin coat of silicone lubricant (Table 5). Apply the lubricant using latex gloves. Do not let loose fibers or lint stick to the O-ring. Fibers can provide a leakage path.



Apply a very thin coat of silicone lube on the O-ring. Using too much silicone lube on the O-ring can be more harmful than using no O-ring lube at all.

4. Install the backup O-ring first as shown in Figure 48 and then install the 2-258 bore O-ring. The backup O-ring cupped side should be facing the 2-258 bore seal O-ring and be placed on the interior edge of the O-ring groove. Place the face O-Ring into the groove.



During installation, do not cut or twist the O-ring. Never force O-rings over sharp corners, screw threads, keyways, slots, or other sharp edges.

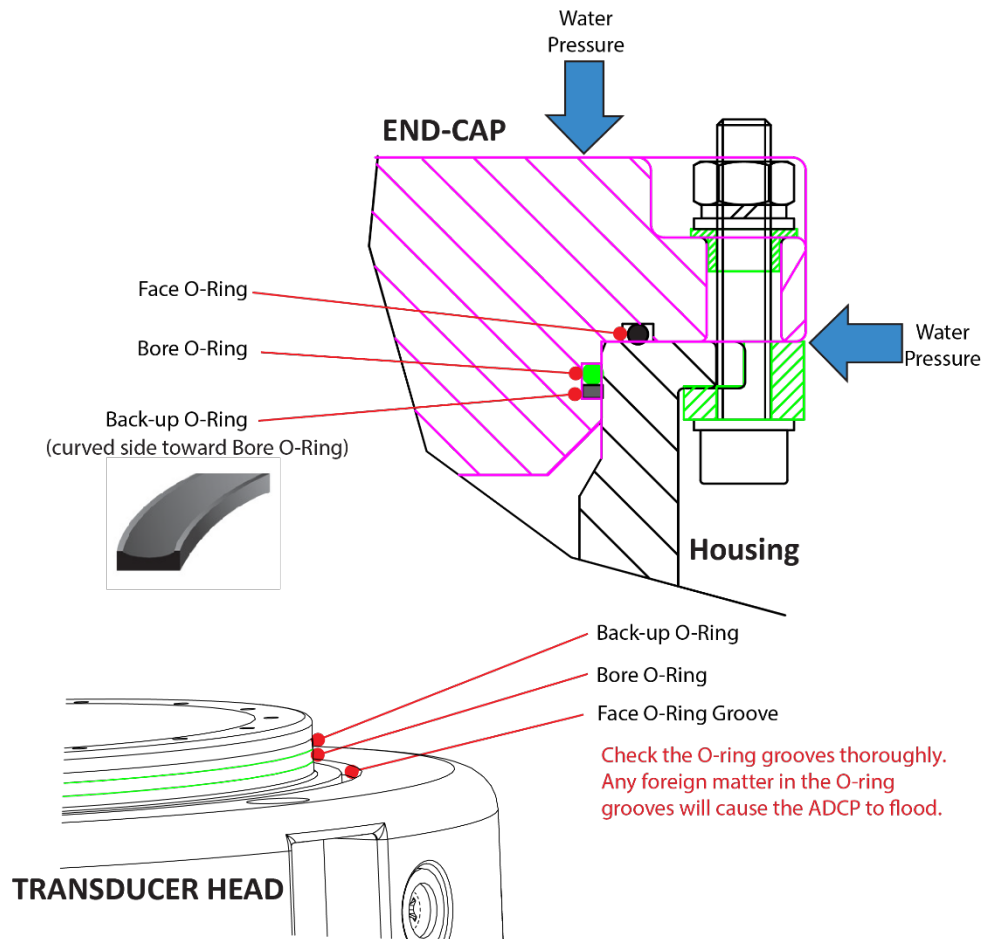


Figure 48. High Pressure O-Ring Detail View

## Purge Plug Inspection & Replacement

The purge plug is included with 3000 meter and greater ADCP systems. This plug is a safety valve and is designed to push out of the system to ensure that there is not excessive pressure inside the system when removing the end cap. **Replace the purge plug O-Rings every two to three years.**

To replace the purge plug O-rings:

1. Remove the M4 plastic screw(s) and flat washer (single-screw purge plug only).
2. Lift off the plug keeper.
3. Remove the purge plug. Remove the old O-rings.
4. Clean and inspect the purge plug. Be sure the O-ring groove is free of foreign matter, scratches, indentations, and pitting. Replace the purge plug if it shows any signs of damage. Look for signs of corrosion such as white deposits in the purge plug housing. If corrosion caused part of the purge plug housing to be visibly damaged, do not redeploy your system. Send it back to TRDI for inspection (see [Returning Systems to TRDI for Service](#)).



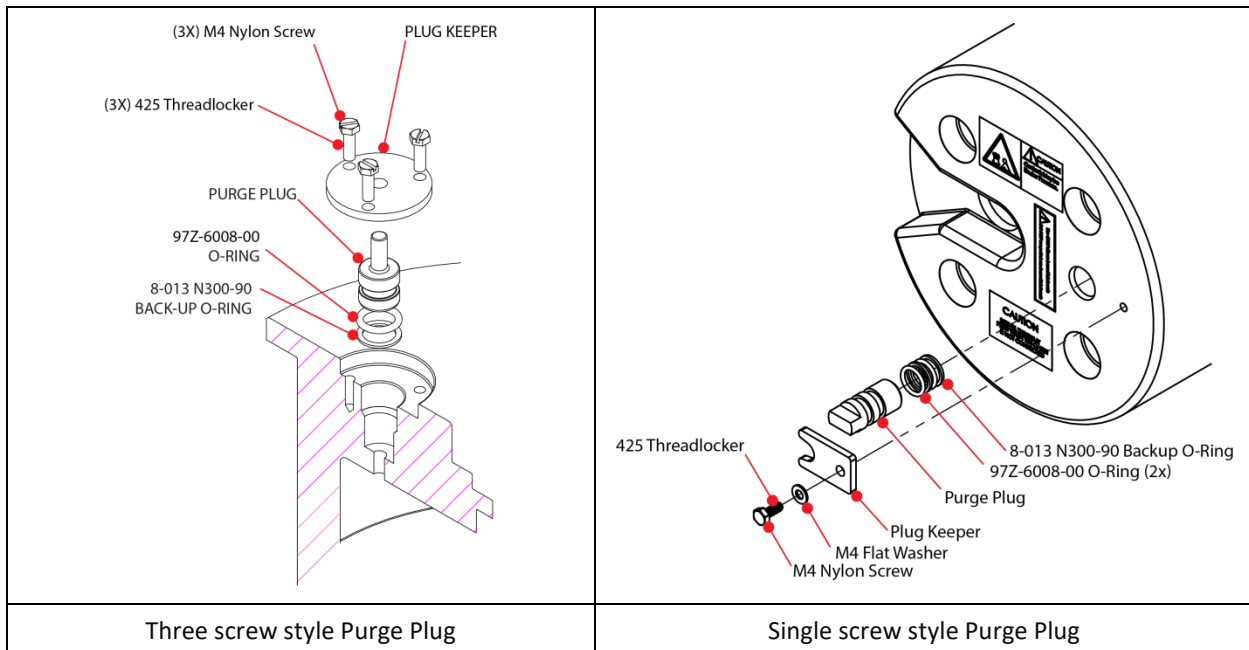
Check the O-ring groove thoroughly. Any foreign matter in the O-ring groove will cause the ADCP to flood.

5. Lubricate the O-ring with a thin coat of silicone lubricant (Table 5). Apply the lubricant using latex gloves. Do not let loose fibers or lint stick to the O-ring. Fibers can provide a leakage path.



Apply a very thin coat of silicone lube on the O-ring. Using too much silicone lube on the O-ring can be more harmful than using no O-ring lube at all.

6. For 6000 meter systems, install the backup O-ring first as shown below and then install the bore O-ring.
7. Insert the purge plug into the housing/end-cap. Install the plug keeper and flat washer (single-screw purge plug only).
8. Apply a drop of 425 thread locker on the M4 screw(s). Tighten the screws to  $0.5 \pm 0.1$  N.m ( $4.0 \pm .5$  IN-LB)



**Figure 49. Purge Plug O-Ring Replacement**

## High-Pressure End-Cap Replacement

To replace the end-cap:

1. Stand the WorkHorse on its transducer face on a soft pad.
2. Inspect, clean, and lubricate the O-rings on the end-cap. Apply a very thin coat of silicone lube on the O-rings.



TRDI recommends you use new O-rings if you are preparing for a deployment.



Apply a very thin coat of silicone lube on the O-ring. Using too much silicone lube on the O-ring can be more harmful than using no O-ring lube at all.

3. Connect the internal I/O connector to the plug on the common mode choke.
4. Place the end-cap on the housing, aligning the mating holes and the beam 3 number embossed on the end-cap with the beam 3 number embossed on the transducer head. When mating the end-cap with the housing flange, try to apply equal pressure to all parts of the O-rings. Make sure the face and bore O-rings remain in the retaining groove.



Check that no wires or any other object is pinched between the end-cap and the housing. Use rubber bands to hold the wiring in place as necessary. If the O-ring is not in the groove or if a wire or other object is pinched, the ADCP will flood.

5. Examine the end-cap assembly nuts, bolts, and washers (8 mm) for corrosion; replace if necessary. The [High-Pressure Parts Location Drawings](#) shows the assembly order of the end-cap mounting hardware. All the hardware items are needed to seal the WorkHorse properly.
6. Install all four sets of hardware until “finger-tight.”
7. Tighten the bolts in small increments in a “cross” pattern until the split washer flattens out, and then tighten each bolt ¼ turn more to compress the face seal O-ring evenly. Tighten the bolts to the recommended torque value of 9.6 Newton-meters (85 pound-inches).



Apply equal pressure to the O-rings as you tighten the bolts. If one bolt is tightened more than the others, the O-rings can become pinched or torn. Damaged O-rings will cause the system to flood.



Do not over tighten the bolts that hold the transducer, housing, and end cap together. If you tighten too much, you can crack or break the plastic housing. On the other hand, leaving the bolts too loose can cause the system to flood. Tighten the hardware to the recommended torque value.



The recommended torque value for the end-cap 8-mm bolts is 9.6 Newton-meters (85 pound-inches).

## High-Pressure Transducer Head Replacement

To replace the transducer head:

1. Stand the WorkHorse on its end-cap.
2. Inspect, clean, and lubricate the O-rings on the transducer head flange. Apply a very thin coat of silicone lube on the O-ring.



TRDI recommends you use new O-rings if you are preparing for a deployment.



Apply a very thin coat of silicone lube on the O-ring. Using too much silicone lube on the O-ring can be more harmful than using no O-ring lube at all.

3. Connect the internal I/O connector to the plug on the common mode choke.
4. Gently lower the transducer head/electronics assembly into the housing, aligning the mating holes and the beam 3 number embossed on the transducer head with the beam 3 number embossed on the end-cap. When mating the housing with the transducer head flange try to apply equal pressure to all parts of the O-rings. Make sure the face and bore O-rings remain in the retaining groove.



Check that no wires or any other object is pinched between the transducer head and the housing. Use rubber bands to hold the wiring in place as necessary. If the O-ring is not in the groove or if a wire or other object is pinched, the ADCP will flood.

5. Examine the transducer assembly nuts, bolts, and washers (8-mm) for corrosion; replace if necessary. The [High-Pressure Parts Location Drawings](#) shows the assembly order of the transducer mounting hardware. All hardware items are needed to seal the WorkHorse properly.

6. Install all four sets of hardware until “finger tight.”
7. Tighten the bolts in small increments in a “cross” pattern until the split washer flattens out, and then tighten each bolt  $\frac{1}{4}$  turn more to compress the face seal O-ring evenly. Tighten the bolts to the recommended torque value of 9.6 Newton-meters (85 pound-inches). Do not deform the plastic bushings.



Apply equal pressure to the O-rings as you tighten the bolts. If one bolt is tightened more than the others, the O-rings can become pinched or torn. Damaged O-rings will cause the system to flood.



Do not over tighten the bolts that hold the transducer, housing, and end cap together. If you tighten too much, you can crack or break the plastic housing. On the other hand, leaving the bolts too loose can cause the system to flood. Tighten the hardware to the recommended torque value.



The recommended torque value for the transducer head 8-mm bolts is 9.6 Newton-meters (85 pound-inches).

## Replacing the Sentinel Battery Packs

The Sentinel system uses battery packs to provide power. Batteries should be replaced when the voltage falls below 30 VDC (measured across the battery connector).



Battery replacement induces both single and double cycle compass errors. The compass accuracy should be verified after replacing the battery pack. The compass does not have to be recalibrated if the compass verification passes specification.

These compass effects can be avoided by using an external battery pack. The external battery housing holds two batteries, and can easily be replaced on-site. If properly used, no compass calibration will be required. The external battery pack provides an option for extended ADCP deployments.



WorkHorse Sentinel batteries are shipped inside the ADCP but not connected. Connect the battery and seal the ADCP before deployment.

### To replace the battery pack:

1. Remove the end-cap (see [End-Cap Removal Procedures](#)).
2. Disconnect the battery cable going to the common mode choke.
3. Remove the four wing nuts, lock washers, and washers holding the battery pack onto the posts (Figure 42).
4. Remove the support plate.
5. Slide out the used battery pack.
6. Use the large rubber bands (supplied with each new pack) to hold the cables and desiccant in place.
7. Slide a new battery pack onto the four posts. Make sure the I/O cable is not pinched by the battery pack.





8. Test the battery pack voltage by measuring across the battery connector. The voltage should be +42 VDC for a new battery pack.



If the battery pack shorts out, it will blow a protective fuse inside the battery pack. The battery pack is then open and will read as zero volts DC.

9. Position the support plate over the four posts.
10. Place a flat washer, lock washer, and wing nut on each of the four posts. Tighten the wing nuts firmly to hold the battery in place.
11. Place a battery pack rubber band (two spare rubber bands are provided with each new battery) around all four wing nuts. This will prevent the wing nuts from backing off the post.



The WorkHorse Sentinel battery packs are held in place by four sets of washers, lock washers, and wing nuts. If the wing nuts are not tight, the assembly of washers and wing nut can become loose and eventually fall onto the PIO board. This has caused the PIO board to short out.

12. Install the desiccant under the rubber bands (see [Replacing the Desiccant Bags](#)).
13. Connect the battery cable going to the PIO board.
14. Install the end-cap (see [End-cap Replacement](#)).
15. Align the compass (see [Compass Calibration](#)).



# Replacing the External Battery Case Packs

The external battery case holds two battery packs to provide power. Batteries should be replaced when the voltage falls below +30 VDC (measured across the battery connector). To replace the battery packs, do the following steps.



The external battery case should not be connected or disconnected underwater. The electrical output power will degrade the connector contacts and present a potential electrical shock hazard to installation personnel when the power connector is short-circuited in water. The external battery case output power cannot be enabled or disabled underwater.

To replace the external battery case battery packs:

1. Remove one end-cap from the external battery pack (see Figure 43).
2. Place the external battery case on its side and carefully pull out the battery pack (attached to the end-cap).
3. Disconnect the battery power cable from the wiring harness.
4. Remove the four wing nuts, lock washers, and washers holding the battery pack onto the posts (see Figure 42).
5. Remove the support plate.
6. Slide out the used battery pack.
7. Slide a new battery pack onto the four posts. Make sure the wiring harness is not pinched by the battery pack. Use the large rubber bands (supplied with each new pack) to hold the cables in place.
8. Position the support plate over the four posts.
9. Place a flat washer, lock washer, and wing nut on each of the four posts. Tighten the nuts to hold the battery in place.
10. Test the battery pack voltage by measuring across the battery connector. The voltage should be +42 VDC for a new battery pack.



If the battery pack shorts out, it will blow a protective fuse inside the battery pack. The battery pack is then open and will read as zero volts DC.

11. Connect the battery power cable to the wiring harness.
12. Install the end-cap/battery pack assembly (see [End-cap Replacement](#)).
13. Repeat steps 1 through 12 to replace the other battery pack.
14. Replace the desiccant bags on each battery just before sealing the external battery case (see [Desiccant Bags](#)).

## WorkHorse Lithium Battery Packs

The optional Workhorse Lithium Battery Packs can be used interchangeably in Workhorse Sentinels. This battery pack is assembled using lithium battery cells that provide 34 VDC with a capacity of approximately 1650 Wh. The battery includes a safety circuit that protects the battery and users against short circuits and provides users the ability to test the pack (see [Testing the Lithium Battery Pack](#)). The circuit also turns the battery off at its end of life, before the battery fully discharges. This happens when about 97% of the battery's capacity is depleted.

Follow the instructions provided in [Replacing the Sentinel Battery Packs](#) when replacing the Lithium battery pack in a Sentinel ADCP or the external battery case. The Lithium battery will fit on the posts the same as the alkaline battery.



Disposal of used battery packs should be done in accordance with applicable regulations, which vary from country to country. In most countries trashing of used batteries is forbidden and disposal can be done through non-profit organizations mandated by local authorities or organized by professionals.



**Figure 50. Workhorse Lithium Battery Pack**



The optional Lithium battery packs are restricted to Cargo Aircraft Only since 1 January 2015. **Do NOT return ADCP units with the optional Lithium battery pack installed.**

## Power on Cycle

WorkHorse ADCPs require +20 to 50 VDC to operate. A fresh alkaline battery provides +42 VDC. The Lithium battery provides +34 VDC. The power supply or battery pack must be able to handle the inrush current as well. Inrush current is the current required to fully charge up the capacitors when power is applied to the ADCP. The capacitors provide a store of energy for use during transmit. The inrush current is as high as 3 Amps rms. The ADCP will draw this amperage until its capacitors are fully charged.

If the power supply or battery pack limits the current or the power drop on the cable is significant, then the power on cycle will take longer. It can take up to one minute. You do not want the power to shut down during the inrush current draw, as this may not allow the ADCP electronics to start.

## AC Power Adapter

The AC power adapter is designed to maintain a 400-ma supply under the ADCP's inrush current. The adapters are 75-Watt supplies, with 48 VDC, 1.5 amp outputs. They will not fall back to 0 amps, 0 volts under a load. Customer provided power supplies might shut themselves down under such a load; when that occurs, the ADCP will not wakeup.

The AC Adapter input voltage is sufficient to override the internal Lithium battery voltage (for example, the ADCP will draw all power from the AC adapter even if the Lithium battery is installed and connected). Always use the AC adapter when testing the ADCP to conserve the battery power.



Before using the optional Lithium battery pack, always run the battery self-test. See [Testing the Lithium Battery Pack](#) for instructions.

Instruments with high inrush currents occasionally trigger the optional Lithium battery pack short circuit detection, which turns the battery off. If this happens, do the following:

- Connect the AC adapter and wait for a minute and then connect the battery pack. Once the ADCP is connected, unplug the AC adapter. The ADCP will work normally after that.

## Testing the Lithium Battery Pack

The optional Lithium battery pack includes a safety circuit that turns the battery off at its end of life, before the battery fully discharges. This happens when about 97% of the battery's capacity is depleted. The circuit also protects the battery and users against short circuits and provides users the ability to test the pack. When the battery detects a short circuit, it waits about 300 us, and then it turns itself off. A red LED on the circuit indicates when it detects a short. The circuit monitors the load across the battery and as soon as the load is removed, it displays the results of its self-test.

Before installing the Lithium battery pack run the self-test by shorting the battery's pins with a bent paperclip. The LED display lasts approximately 10 seconds and indicates the battery status:

- A continuous green LED tells you the battery is new.
- A flashing green LED tells you the battery has been used, but can still power an ADCP.
- A continuous red LED tells you the battery has been disconnected at its end of life and cannot be used any more.
- If there is no LED light at all, the circuit is defective and you should not use the battery.



You should run the self-test when you receive new lithium battery packs. This way, there is time to replace defective batteries before you deploy. You should also run the self-test just before installing the battery.

## Calibrating the Compass

The main reason for compass calibration is battery replacement. Each new battery carries a different magnetic signature. The compass calibration algorithm corrects for the distortions caused by the battery to give you an accurate measurement.

To achieve the best possible field calibration of the compass, the compass calibration should be performed:

- In a “magnetically clean” environment, i.e. in an area free from stray magnetic fields (electronics, power lines, etc.) and magnetic materials such as iron.
- As close as possible to the actual deployment site (so that during calibration the instrument is measuring a magnetic field intensity and dip angle that are as close as possible to the as-deployed environment)
- With a large variety of instrument orientations (ideally tilting the instrument by 30 degrees or more during orientation).

- TRDI recommends that if you are having trouble calibrating the Workhorse II ADCP compass that you move the system and/or ensure the area around the system is clear of electrical equipment and ferrous materials.



In an oil & gas environment, it is typically impossible to meet the first two requirements above. Oil fields are full of metal structures that preclude a “magnetically clean” environment. Even in standard oceanography, for example a deep-water deployment in the open ocean, it is not possible to meet both requirements because any location reasonably near the deployment site is aboard a ship, which will be a decidedly magnetically dirty environment. Therefore, the customer typically must choose between calibrating a long way away from the deployment site or use the factory default calibration.



Before calibrating a WH compass, the compass **MUST** first be reset to factory calibration (AR command); then a calibration and verification can be done. If these results are not acceptable, the compass should again be reset to factory again and the calibration repeated.

## Compass Background

The compass calibration algorithm collects magnetic field vector information for various measured headings during the calibration. Hard and soft iron effects rotating with the compass are made observable during the calibration by causing the local field to be perturbed as the compass is spun during the calibration. That is, each component of the hard and soft iron has to alternately increase the local field for some orientations and decrease for orientations 180 degrees (or 90 degrees for soft iron) from those orientations for the algorithm to “notice” it. Tilting and rotating the compass about the vertical axis is sufficient to do this.

There are three compass calibrations to choose from; one only corrects for hard iron while the second corrects for both hard and soft iron characteristics for materials rotating with the ADCP. The third method provides calibration for a [single tilt orientation](#). Hard iron effects are related to residual magnetic fields and cause single cycle errors while soft iron effects are related to magnetic permeability that distorts the earth’s magnetic field and causes double cycle errors. In general, the hard iron calibration is recommended because the effect of hard iron dominates soft iron. If a large double cycle error exists, then use the combined hard and soft iron calibration.

## Preparing for Calibration

To prepare for compass calibration:

1. Protect the Workhorse surfaces from contact or abrasion during calibration. Use the transducer cover to protect the ADCP transducer faces during calibration if the calibration is in a face down orientation.
2. Compass calibration should be performed free from ambient magnetic fields. Choose a calibration location outside, away from magnetic materials. Nearby steel, iron, magnets, and other magnetic fields will degrade the calibration and accuracy and will provide a poor calibration.
3. Use a wood or plastic test platform at least 1 meter (~3 feet) high to move away from metal under the ground.

If you are using a calibration stand, place the ADCP in the stand in the same orientation as it will be deployed.



The WH-V is shown with a Teledyne RD Instruments Workhorse Sentinel ADCP loaded for UPWARD Profile Calibration (center) and loaded for a DOWNWARD Looking Profile Calibration (right).



Compass calibration stands are not required to calibrate the WorkHorse compass, but they do make it much easier and increase the calibration accuracy.



If you will deploy your WorkHorse looking up, calibrate it looking up. If you will deploy it looking down, calibrate it looking down.



If you calibrate the compass in one direction (up or down) and deploy the ADCP in the opposite direction (i.e. calibrate it in a downward position and deploy it in an upward position) the compass calibration will be invalid. Compass errors in excess of 5 degrees may occur.

4. Connect the WorkHorse as shown in [Setting up the WorkHorse System](#).

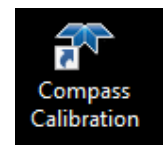
## WHII ISM Compass Calibration



This section applies to the WHII electronics only. See [How do I know if I have WH or WHII electronics?](#) to determine what electronics are installed in the system.

### To calibrate the internal compass:

1. Start the *ISM Compass Calibration* software.
2. Set up the communication parameters between the *Compass Calibration* software and the ADCP by clicking on the **Comm. Port** button.
3. For the **Break Type**, select **Soft**.





Communication errors may occur during calibration when using a slow communication Baud rate. If you receive a *Failed to get calibration data...* message, try increasing the Baud rate (115200 Baud is recommended).

The Workhorse II uses a Soft break for the compass calibration.

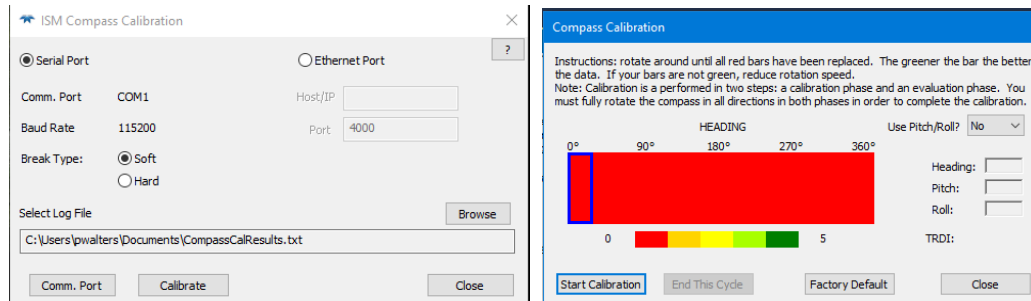


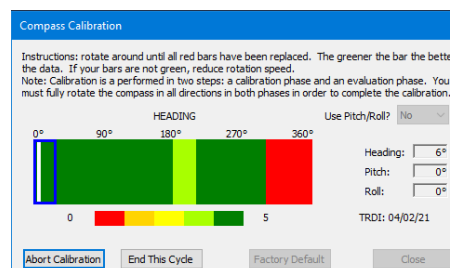
Figure 51. Compass Calibration

4. Click the **Calibrate** button.
5. Select **Use Pitch/Roll?**
  - Select **No**. This calibration requires two rotations (one for calibration and one for verification).
  - Select **Yes**. This calibration requires eight rotations (four for calibration and four for verification).

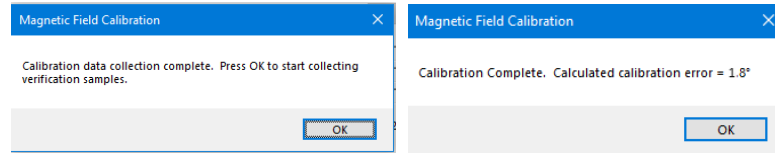


TRDI recommends calibrating with a large variety of instrument orientations (ideally tilting the instrument by 30 degrees or more during orientation).

6. Click the **Start Calibration** button.
7. As you rotate the Workhorse II, the bars will change color. The Blue bar indicates where you are in the rotations.
  - Green – Good
  - Light Green – Acceptable
  - Yellow – Within parameters (one or two yellow bars for the entire rotation is OK)
  - Orange – Unacceptable - Rotate slower!
  - Red – Not measured



8. When the first rotation(s) are complete, click **OK** on the message box to continue with the verification samples.



9. When the second rotation(s) are complete, click **OK** on the message box. The calibration error should be less than 2 degrees.



Stability of the instrument during the calibration process, as well as a non-magnetic calibration site is essential to getting the lowest overall error value.

## WHII ISM Compass Post Calibration



This section applies to the WHII electronics only. See [How do I know if I have WH or WHII electronics?](#) to determine what electronics are installed in the system.

Compass post calibration corrects for heading errors due to hard and soft iron effects in the Workhorse II reference frame during the deployment. Often post calibration will provide results more reliable than when only a pre-deployment calibration is performed.

### Some example scenarios where the post calibration is useful:

- The Workhorse II is installed on a mooring and rotates freely sampling the magnetic environment throughout the deployment.
- The magnetic properties of the installation changed after the pre-deployment calibration. A battery pack was added, or the Workhorse II was installed in a mounting frame constructed of a ferrous material.
- The Workhorse II was subject to magnetic interference during the pre-deployment calibration.

### Post calibration will not be effective if:

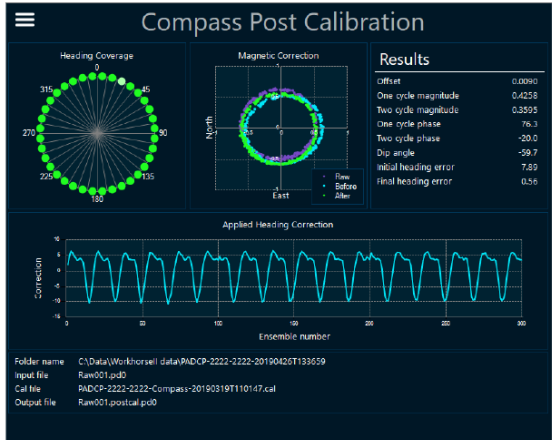
- The magnetic interference is not in the Workhorse II reference frame. The Workhorse is deployed adjacent to a large metal structure like a bridge or ship for example.
- The magnetic properties change over the deployment.



**Heading Coverage:** Green indicates heading data was collected. Light green indicates some heading data was collected. Missing circles indicates the ADCP did not collect heading data for that direction.

**Magnetic Correction:** The Before series (shown in cyan) is the Raw data (shown in purple) with the existing magnetic correction applied, the After series (shown in green) is the Raw data with the post-calibration correction applied.

```
Example Postcal.txt file:
Date: 10/20/2021 3:05 PM
Offset: 9.02e-003
One cycle: 4.26e-001
Two Cycle: 3.60e-001
One cycle phase: -76.3
Two cycle phase: -20.0
Dip angle: -59.7
Initial heading error: 7.9°
New heading error: 0.56°
Use Post-cal: true
```



The *filename.pd0* data file and the *filename.cal* calibration file must be in the same folder.

Post Calibration will create the *filename.postcal.txt* and *filename.postcal.pd0* files.

The original raw data is not changed. Use the *filename.postcal.pd0* file to view the data with the post compass calibration correction applied.

The **Offset** is the amount by which the calibrated circle must be moved to be centered on zero.

The **One-Cycle Magnitude and Phase** are the RMS hard iron correction. That is, how big is the circle and at what angle is its origin.

The **Two-Cycle Magnitude and Phase** are the RMS soft iron correction. That is, how round (non-elliptical) is the circle and at what angle is its origin.

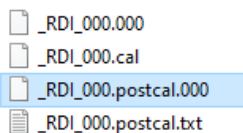
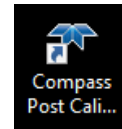
**Dip angle** is the angle made with the horizontal by the Earth's magnetic field lines.

**Initial Heading Error** is the compass error before the post calibration is applied.

**Final Heading Error** is the compass error after the post calibration is applied.

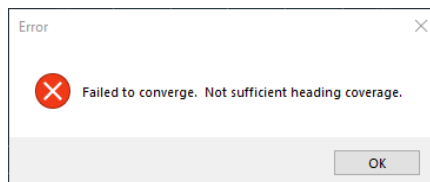
**To post calibrate the WHII data:**

1. Use *TRDI Toolz* to download the data from the CompactFlash recorder. For example, the pd0 data file is named *\_RDI\_000.000* and the *\_RDI\_000.cal* is the post calibration file and both files are downloaded to the same folder.
2. Start the *Compass Post Calibration* software and click the **Menu** button to select the PD0 data file (\*.000).
3. *Compass Post Calibration* will create the *filename.postcal.txt* and *filename.postcal.000* files. The original raw data is not changed. Use the *filename.postcal.000* file to view the data with the post compass calibration correction applied.



The *.cal* file is created during data collection and is recorded to the CompactFlash recorder with the *.000* pd0 data file.

Post calibration relies upon the instrument moving sufficiently during the deployment to collect "raw magnetometer" data for the heading coverage. If the *.cal* file did not have sufficient heading coverage, then the post calibration will fail to converge.



# WH Flux Gate Compass Calibration Verification



This section applies to the original WH electronics only. See [How do I know if I have WH or WHII electronics?](#) to determine what electronics are installed in the system.

Compass calibration verification is an automated built-in test that measures how well the compass is calibrated. The procedure measures compass parameters at every 5° of rotation for a full 360° rotation. When it has collected data for all required directions, the WorkHorse computes and displays the results.



[Verify](#) the compass if you have just replaced the memory module or any ferrous metals is relocated inside or around the WorkHorse housing. [Calibrate](#) the compass if the batteries have been replaced (see [Compass Calibration Procedure](#)).

To verify the compass calibration:

1. Prepare the ADCP for calibration (see [Preparing for Calibration](#)).
2. Using *TRDI Toolz*, send a Break to wake up the WorkHorse.
3. At the > prompt, type **AX** and press the **Return** key.
4. When prompted, rotate the WorkHorse slowly 360 degrees (approximately 5 degrees per second). Pay particular attention to the Overall Error. For example;

HEADING ERROR ESTIMATE FOR THE CURRENT COMPASS CALIBRATION:

**OVERALL ERROR:**

Peak Double + Single Cycle Error (should be < 5()): ( 1.55(

DETAILED ERROR SUMMARY:

Single Cycle Error: ( 1.54(

Double Cycle Error: ( 0.07(

Largest Double plus Single Cycle Error: ( 1.61(

RMS of 3rd Order and Higher + Random Error: ( 0.31(

If the overall error is less than 2°, the compass does not require alignment. You can align the compass to reduce the overall error even more (if desired).

## WH Flux Gate Compass Calibration

The built-in automated compass calibration procedure is similar to the alignment verification, but requires three rotations instead of one. The WorkHorse uses the first two rotations to compute a new calibration matrix and the third to verify the calibration. It will not accept the new matrix unless the calibration was carried out properly, and it asks you to verify that you want to use the new calibration if it is not as good as the previous calibration. While you are turning the WorkHorse for the two calibration rotations, the WorkHorse checks the quality of the previous calibration and displays the results. It compares these results with the results of the third calibration rotation.

To calibrate the compass:

1. Prepare the ADCP for calibration (see [Preparing for Calibration](#)).
2. Using *TRDI Toolz*, send a Break to wake up the ADCP.
3. At the > prompt, type **AR** and press the **Return** key. This will return the compass to the factory calibration matrix.
4. At the > prompt, type **AF** and press the **Return** key. Choose option “a” or “b” to start the calibration procedure.

Field Calibration Procedure

Choose calibration method:

- a. Remove hard iron error (single cycle) only.
- b. Remove hard and soft iron error (single + double cycle).
- c. Calibration for a single tilt orientation (single + double cycle).
- d. Help.

e. Quit.



In general, the hard iron calibration is recommended for Monitor and Mariner systems because the effect of hard iron dominates soft iron.

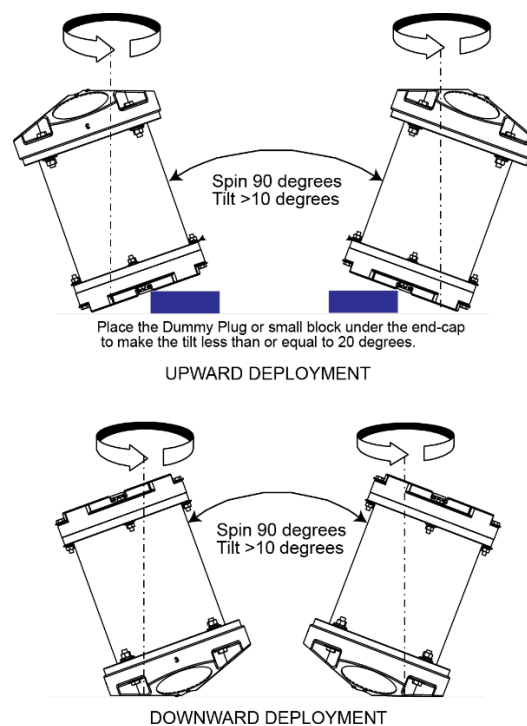
For Sentinel systems that have just replaced the battery, then use the combined hard and soft iron calibration. Changing the WorkHorse Sentinel batteries should only change the hard-iron signature of the ADCP, but can induce both single and double cycle compass errors.

5. Tilt the ADCP (see Figure 52). Tilt an upward-looking WorkHorse with a block under one side of the end-cap. A 35-mm block will give you an 11-degree tilt. Check the on-screen instructions to see if the orientation is OK. Adjust as necessary.



The tilts must remain constant during the rotations. The transducer beam is the center point of the rotation.

6. When prompted, rotate the ADCP slowly 360 degrees (approximately 5 degrees per second).
7. The second rotation requires the ADCP to be tilted 15 degrees in another direction than from the first rotation (see Figure 52). Follow the on-screen instructions to orient the ADCP correctly. When prompted, rotate the ADCP slowly 360 degrees (approximately 5 degrees per second).
8. The third rotation requires the ADCP to be tilted 15 degrees in another direction than from the first and second rotations. Follow the on-screen instructions to orient the ADCP correctly.
9. If the calibration procedure is successful, it records the new calibration matrix to nonvolatile memory. The ADCP will not change its matrix unless the calibration is properly carried out.
10. If the calibration procedure is not successful, return your ADCP to the original factory calibration, by using the AR-command. Try using the AR-command if you have trouble calibrating your compass. In some circumstances, a defective compass calibration matrix can prevent proper calibration.



**Figure 52. Compass Calibration**

## Single-Tilt Compass Calibration Procedure

This procedure is used to correct the ADCP's internal flux-gate compass for one-cycle deviation errors. The compass correction procedure given here can be used in place of the [Compass Calibration](#) procedures if you are using a WorkHorse ADCP with firmware version 16.30 or higher.

During this procedure, the ADCP must be rotated in a complete 360 circle no faster than 5 degrees per second. This calibration can be done in the water (recommended) or on shore. It is important to reduce any pitch and roll effects during the turn and avoid any acceleration.



This calibration is intended for applications where tilting the unit is not practical. This calibration is only applicable to the tilt orientation the unit is rotated about during the calibration.



Single tilt calibration does a hard-iron correction only. Changing the WorkHorse Sentinel batteries should only change the hard-iron signature of the ADCP, but can induce both single and double cycle compass errors. A single-tilt calibration should suffice, but performing a full [hard and soft iron calibration](#) is always a safer route whenever possible.

To calibrate the compass:

1. Mount the ADCP in the boat as it will be used to acquire data.
2. Start *TRDI Toolz*.
3. At the ">" prompt, type **AR** and press the **Return** key. Type **Y** to return the Fluxgate Calibration Matrices with the factory original values.

>AR

```
Do you really want to write over the active fluxgate calibration
data [y or n]?Y
```

```
Fluxgate Calibration Matrices Updated with Factory Original Values.
```

>

4. At the ">" prompt, type **AF** and press the **Return** key. Select option "c" Calibration for a single tilt orientation (single + double cycle).

```
Field Calibration Procedure
```

```
Choose calibration method:
```

- a. Remove hard iron error (single cycle) only.
- b. Remove hard and soft iron error (single + double cycle).
- c. Calibration for a single tilt orientation (single + double cycle).
- d. Help.
- e. Quit.

c

5. During the calibration, drive the boat in a continuous small circle. You can accomplish this by adjusting the throttle to just above idle and steering either hard left or hard right. You will want to reduce any pitch and roll effects during the turn. Do not move about the boat as this may cause the boat to change how it sits in the water. Avoid any accelerations during the calibration. If you are working on a river, you will find that you drift downstream as you perform the circles. This will not affect the calibration.
6. While you continue to drive the boat in circles, press any key to start the compass calibration. Follow the on screen prompts.
7. Press **D** for details.

```
HEADING ERROR ESTIMATE FOR THE CURRENT COMPASS CALIBRATION:
```

```
OVERALL ERROR:
```

```
Peak Double + Single Cycle Error (should be < 5ø): ñ 1.73ø
```

```
DETAILED ERROR SUMMARY:
```

```
Single Cycle Error: ñ 1.70ø
```

```
Double Cycle Error: ñ 0.42ø
```

Largest Double plus Single Cycle Error:	ñ 2.12ø
RMS of 3rd Order and Higher + Random Error:	ñ 0.77ø
Orientation: Down	
Average Pitch: -0.18ø	Pitch Standard Dev: 0.37ø
Average Roll: 0.35ø	Roll Standard Dev: 0.45ø

Successfully evaluated compass performance for the current compass calibration.

Press C to display Percent Horizontal Field Components  
Relative to Calibration or any other key to continue....  
Calibration parameters have been updated in NRAM.

>

8. You can now use the ADCP with its corrected compass.

## Mariner Adapter Plate

The adapter plate helps mount the Mariner transducer head to a vessel. See the [Outline Installation Drawings](#) for dimensions. The following procedure explains how to install and remove the Adapter Plate on a Workhorse II Mariner ADCP.

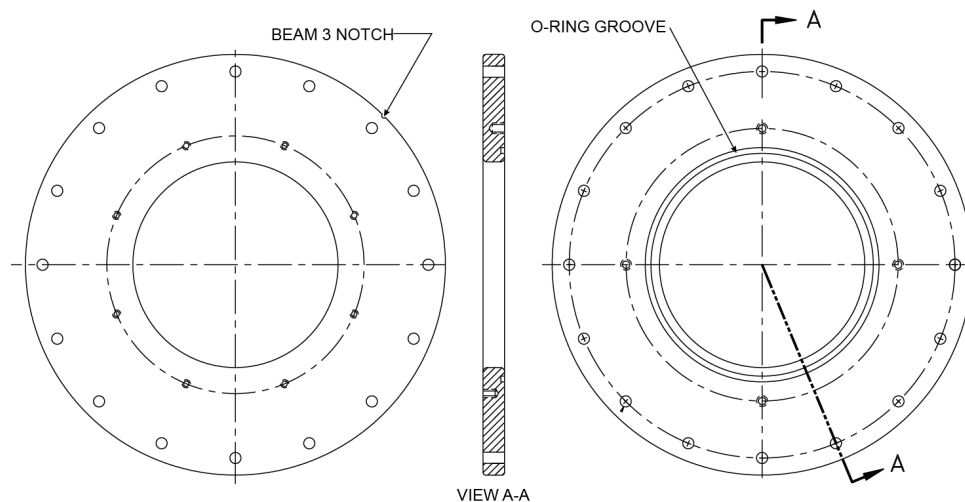


Figure 53. Mariner Adapter Plate

## Installing the Adapter Plate

To install the adapter plate:

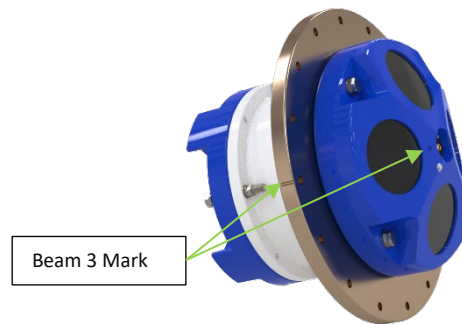
1. Remove the Transducer Assembly (see [Transducer Head Assembly Removal](#)).
2. Inspect and clean the O-ring groove of the Housing Assembly.
3. Inspect, clean, and lubricate the O-ring (2-260) on the Housing Assembly where the Transducer Assembly was just mounted. Apply a very thin coat of silicone lube on the O-ring.



Apply a very thin coat of silicone lube on the O-ring. Using too much silicone lube on the O-ring can be more harmful than using no O-ring lube at all.

4. Inspect and clean the Adapter Plate. Be sure no scratches, dents, or foreign matter is around the area that will be contact with the O-ring on the Housing Assembly.

- Place the adapter plate on the Housing Assembly, ensuring that the O-ring is not pinched or damaged. Rotate the plate such that the Beam 3 alignment notch in the plate is in alignment with the beam 3 mark on the transducer.



Check that no wires or any other object is pinched between the adapter plate and the housing. Use rubber bands to hold the wiring in place as necessary. If the O-ring is not in the groove or if a wire or other object is pinched, the ADCP will flood.

- Using four of the titanium 8-mm bolts supplied in the Adapter Plate Kit, secure the Adapter Plate to the Housing Assembly. Install the split lock washer next to the head of the bolt followed by a flat washer before installing the 8-mm bolts.
- Install all four sets of hardware until “finger-tight.”
- Tighten the bolts in small increments in a “cross” pattern until the split washer flattens out, and then tighten each bolt  $\frac{1}{4}$  turn more to compress the O-ring evenly. Tighten the bolts to the recommended torque value of 9.6 Newton-meters (85 pound-inches).



Apply equal pressure to the O-ring as you tighten the bolts. If one bolt is tightened more than the others, the O-ring can become pinched or torn. A Damaged O-ring will cause the system to flood.



Do not over tighten the bolts that hold the transducer, housing, and end cap together. If you tighten too far, you can crack or break the plastic housing flange. On the other hand, leaving the bolts too loose can cause the system to flood. Tighten the hardware to the recommended torque value.



The recommended torque value for the transducer 8-mm bolts is 9.6 Newton-meters (85 pound-inches).

- Install a new desiccant bag from the Adapter Plate Kit into the Housing Assembly.
- Inspect and clean the O-ring groove of the Adapter Plate.
- Inspect, clean, and lubricate the O-ring (2-260) from the Adapter Plate Kit and set this O-ring into the groove on the Adapter Plate.
- Connect the cable from the end cap assembly to the Power I/O board on the Transducer Assembly.
- Place the Transducer Assembly onto the Adapter Plate, ensuring that the O-ring is not pinched or damaged. Rotate the Transducer Assembly such that the beam-3 mark is aligned with both the alignment notch in the Adapter Plate and the beam-3 arrow on the end cap.



Check that no wires or any other object is pinched between the transducer head assembly and the adapter plate. Use rubber bands to hold the wiring in place as necessary. If the O-ring is not in the groove or if a wire or other object is pinched, the ADCP will flood.

14. Using the remaining four of the titanium 8-mm bolts supplied in the Adapter Plate Kit, secure the Transducer Assembly to the Housing Assembly. You should install the split lock washer next to the head of the bolt followed by a flat washer before installing the 8-mm bolts.
15. Install all four sets of hardware until “finger-tight.”
16. Tighten the bolts in small increments in a “cross” pattern until the split washer flattens out, and then tighten each bolt  $\frac{1}{4}$  turn more to compress the O-ring evenly. Tighten the bolts to the recommended torque value of 9.6 Newton-meters (85 pound-inches).



Apply equal pressure to the O-ring as you tighten the bolts. If one bolt is tightened more than the others, the O-ring can become pinched or torn. A Damaged O-ring will cause the system to flood.



Do not over tighten the bolts that hold the transducer, housing, and end cap together. If you tighten too far, you can crack or break the plastic housing flange. On the other hand, leaving the bolts too loose can cause the system to flood. Tighten the hardware to the recommended torque value.



The recommended torque value for the transducer 8-mm bolts is 9.6 Newton-meters (85 pound-inches).

## Removing the Adapter Plate

### To remove the adapter plate:

1. Remove the Transducer Assembly (see [Transducer Head Assembly Removal](#)).
2. Remove the four titanium 8-mm bolts that secure the Adapter Plate to the Housing Assembly.
3. Separate the Adapter Plate from the Housing Assembly.
4. Install the Transducer Assembly (see [Transducer Head Assembly Replacement](#)).



# Periodic Maintenance Items

## Replacing the Desiccant Bags

Desiccant bags are used to dehumidify the housing interior. Desiccant is essential in deployments with plastic housings. The factory-supplied desiccant lasts a year at specified WorkHorse deployment depths and temperatures. Remember that desiccant rapidly absorbs moisture from normal room air.

The average dry weight of a new desiccant bag is 7.2 grams (5%). The weight increases to 8.4 to 9 grams for a “used” desiccant bag. Used desiccant bags may be dried at 250° for 14 hours. As a minimum, replace the desiccant bags (Table 5) whenever you are preparing to deploy or store the WorkHorse for an extended time.



Do not open the desiccant bag. Contact with the silica gel can cause nose, throat, and skin irritation.

Do not puncture or tear the desiccant bag. Do not use desiccant bags that are torn or open.



Desiccant bags are shipped in an airtight aluminum bag to ensure maximum effectiveness. There is a moisture indicator inside the bag. If the moisture indicator is pink, do not use the desiccant bag until it has been dried. TRDI recommends replacing the desiccant bag just before the deployment.

To replace the desiccant:

1. Remove the transducer head (see [Transducer Head Assembly Removal](#)).
2. Remove the new desiccant bags from the airtight aluminum bag.
3. Remove the old desiccant bags and install two new ones. For Monitor and Mariner systems, place the desiccant bags (Table 5) between the PIO board and the end-cap. For Sentinel systems, place the desiccant under one of the rubber bands on the battery pack.



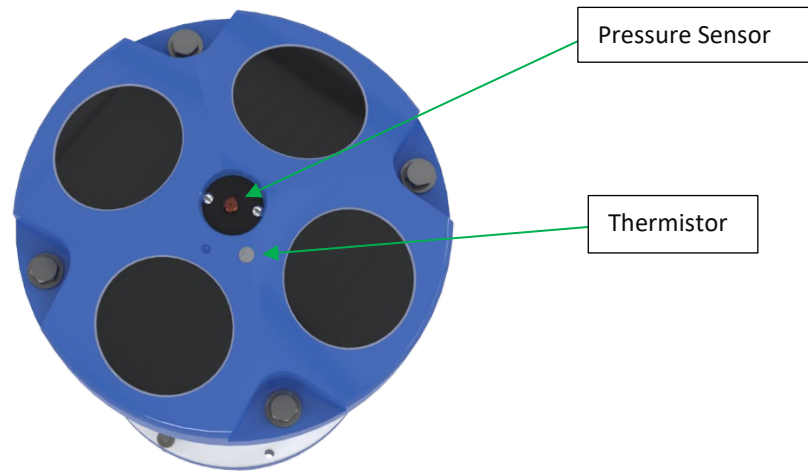
4. Install the transducer head (see [Transducer Head Assembly Replacement](#)).

## Cleaning the Thermistor Cover

In order to respond quickly to changes in the water temperature, water must be able to flow over the sensor. Do not block the sensor or paint over it with antifouling paint. Remove any biofouling as soon as possible.



The Thermistor is embedded in the transducer head. The sensor is under a titanium cover that is highly resistant to corrosion.



**Figure 54.** Thermistor and Pressure Sensor

## Cleaning the Pressure Sensor Port

In order to read the water pressure, water must be able to flow through the copper screw on the pressure sensor. The tiny hole in the copper screw may at times be blocked. Use the following procedure and Figure 55 to clean the screw.



The pressure sensor is optional. It may not be included on your system.

To clean the pressure sensor port:

1. Place the ADCP on its' end-cap. Use a soft pad to protect the ADCP.
2. Use a straight-slot screwdriver to remove the copper pressure sensor port screw.
3. Gently clean out the hole in the copper screw with a needle. If the hole becomes enlarged or the screw is corroded, replace the screw. A replacement copper screw is included in the spare parts kit (part number 817-1067-00).
4. Install the copper screw. Tighten the screw "finger tight" (2 in/lbs). Do not over tighten the screw or you may strip the threads on the plastic cover disc. If this happens, return the ADCP to TRDI for repair.



The pressure sensor installed on the high pressure WorkHorse systems is installed in an anodized aluminum cavity that includes a plastic protective cover to hold the copper screw. This cover is held into place with two M3 screws. The holes where the M3 screws are inserted in the 6000 meter pressure sensor housing are anodized aluminum.

TRDI knows from our experience that it is difficult to anodize sharp edges on threaded holes such as these. In marine and fresh water environments, poor anodizing on aluminum will lead to corrosion problems. **Always inspect for corrosion in this (and all) areas between deployments.**

On 6000 meter WorkHorse systems:

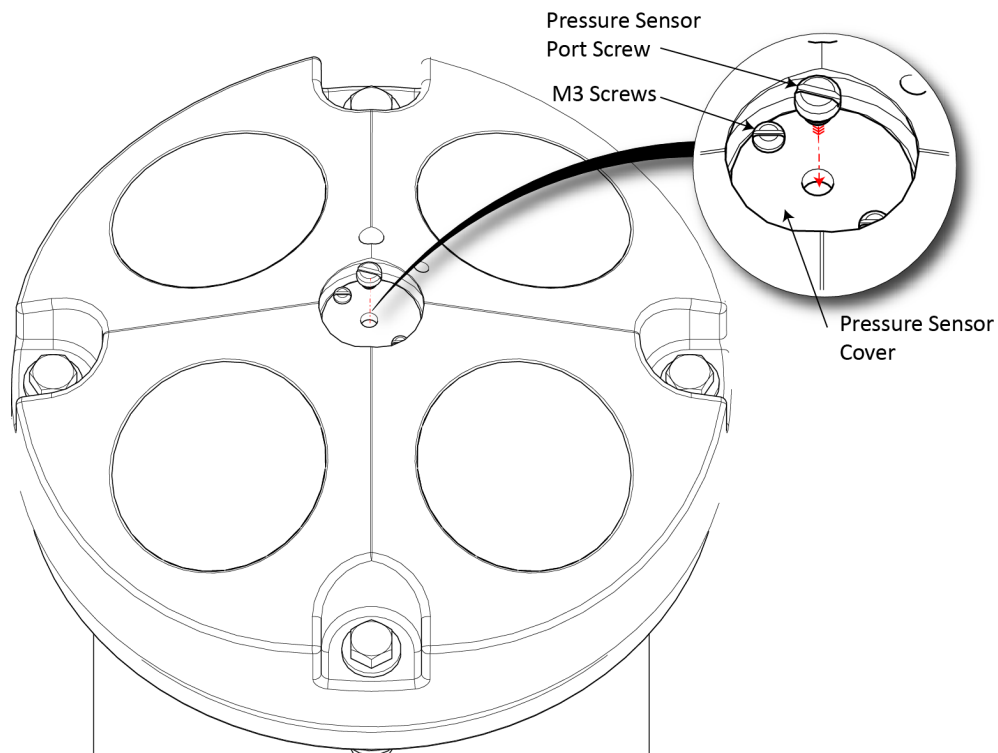
1. Remove the M3 screws and cover disk. Look for signs of corrosion such as white deposits. If corrosion caused part of the pressure sensor housing to be visibly damaged, do not redeploy your system. Send it back to TRDI for inspection (see [Returning Systems to TRDI for Service](#)).
2. Clean both M3 screw mounting holes with a thin brush and lime based product. Flush the holes with the lime based product if you do not have a brush available. Be sure to clean and remove any signs of corrosion.
3. Brush the M3 screws with marine environment grease such as Aqua Shield® grease. Use gloves as the grease tends to stick to your skin. Note that the grease is incompressible and therefore apply a thin layer to the screws to avoid binding or difficulty in the installation of the screws in the mounting holes. Place the cover disk over the pressure sensor and tighten the screws "finger tight" (2 in/lbs).
4. Gently clean out the hole in the copper screw with a needle. If the hole becomes enlarged or the screw is corroded, replace the screw. A replacement copper screw is included in the spare parts kit (part number 817-1067-00).
5. Install the copper screw. Tighten the screw "finger tight" (2 in/lbs). Do not over tighten the screw or you may strip the threads on the plastic cover disc. If this happens, return the ADCP to TRDI for repair.



The pressure sensor is filled with silicone oil. Never poke a needle or other object through the copper screw while the screw is installed over the pressure sensor. You will perforate the sensor, causing it to fail.

Do not attempt to clean the surface of the pressure sensor. The diaphragm is very thin and easy to damage. Flush with low-flow fresh water if sand is in the sensor cavity.

If the pressure sensor surface looks corroded or is bowed outward, then contact TRDI for servicing. Do not attempt to remove the pressure sensor. It is not replaceable in the field.



**Figure 55. WorkHorse Pressure Sensor**

## Formatting the CompactFlash Memory Card



This section applies to the WHII electronics only. See [How do I know if I have WH or WHII electronics?](#) to determine what electronics are installed in the system.

The CompactFlash Memory Card (Sentinel only) should be formatted before a deployment.

### To format the recorder:

1. Start *TRDI Toolz*.
2. To recover data, leave the card in the Workhorse II and use *TRDI Toolz*. Click **Tools, Download Data**.
3. Send the command RE ErAsE <volume label>. RE ErAsE erases and formats the CompactFlash memory card. This command is case sensitive. Use RE ErAsE < volume label > to assign a volume label. The default volume label is "NO NAME ".



Once erased, data is not recoverable.

Do not format or delete files from the CompactFlash card using Windows®. This may leave hidden files on the card. Always use the ADCP's RE ErAsE command to format and delete data from the CompactFlash card recorder.

A recorder card with a file count more than 50 files will cause a noticeable delay between the first ensemble and the Start Pinging (CS) command. If this delay is a concern, ensure that unwanted files are cleared before starting the deployment.

The maximum memory capacity not to exceed 4GB per deployment.

## Replacing the CompactFlash Recorder

The CompactFlash Card recorder is located on the Workhorse II Processor (WHP) board inside the Workhorse II's electronics.

### To remove or install a CompactFlash card:

1. Turn off power to the Workhorse II.
2. Remove the transducer head (see [Transducer Head Assembly Removal](#)).
3. Remove the CompactFlash card by pushing the button on the side of the card slot. The card should "pop" out of the connector. If you cannot reach the release button with your finger, use a plastic pen or non-conductive tool to depress the button.
4. Install the CompactFlash card back into the card slot with the lip facing away from the transducer. If the CompactFlash card is inserted upside down, it will not seat all the way.



The compact flash card can be inserted upside down, and with some force the pins can be bent. Do not try to force the card into the connector. CompactFlash cards slide easily in when properly oriented.

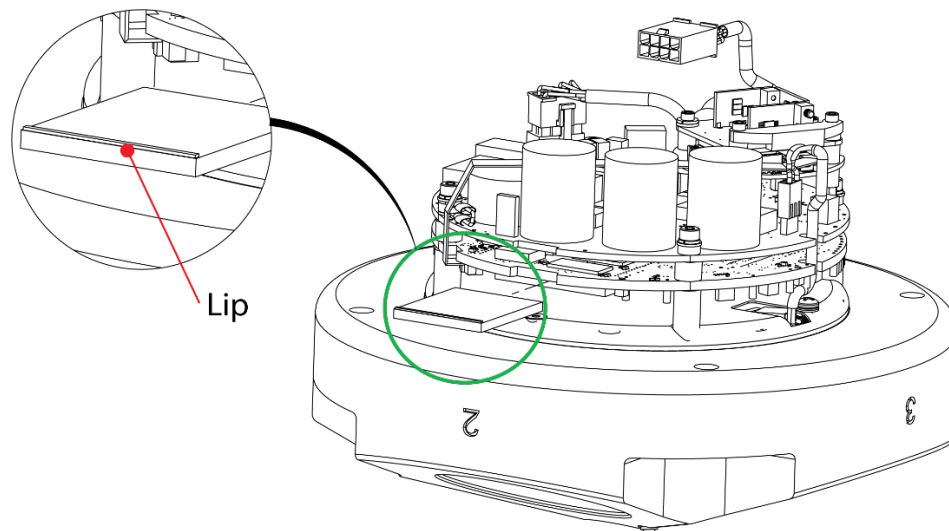


Figure 56. Installing the CompactFlash Card

5. Install the transducer head (see [Transducer Head Assembly Replacement](#)).

## Replacing the PC Card Recorder



This section applies to the original WH electronics only. See [How do I know if I have WH or WHII electronics?](#) to determine what electronics are installed in the system.

The PC Card recorder is located on the Digital Signal Processor (DSP) board inside the WorkHorse's electronics (see Figure 57). To recover data, the card can be removed and used in a personal computer (PC), or left in the WorkHorse, and accessed by using *TRDI Toolz*.

### To remove or install a PC card:

1. Turn off power to the WorkHorse.
2. Remove the transducer head (see [Transducer Head Assembly Removal](#)).
3. Remove the PC cards by pushing the button on the side of the PCMCIA card slot. The card should “pop” out of the connector. If you cannot reach the release button with your finger, use a plastic pen or non-conductive tool to depress the button. Do not try to force the card in or out of the connector. PC cards slide easily in or out when properly oriented.



Figure 57. PC Card Recorder

4. When you are finished recovering the data, install the PC card back into the DSP board. PC cards install with the label side toward the face of the transducer.
5. Install the transducer head (see [Transducer Head Assembly Replacement](#)).



Do not use a PCMCIA adapter for compact flash cards. These do not work.




Do not delete files from the PC card using Windows®. This may leave hidden files on the card. Always use the ADCP's erase command to delete data from the PC card recorder.

## Installing Firmware Upgrades

The firmware for WH and WHII ADCPs is located on flash RAM chips. Firmware upgrades can be downloaded from TRDI's software portal (<https://tm-portal.force.com/TMsoftwareportal>). If the firmware upgrade is not available via the web, then please contact Field Service ([rdifs@teledyne.com](mailto:rdifs@teledyne.com)) to request a copy.

### To install a firmware update:

1. Setup the communication parameters between *TRDI Toolz* and the ADCP.
2. Wake up the ADCP by pressing the  button.
3. Click **Tools, Firmware Update**.
4. Unzip the downloaded file. Select the \*.abs firmware update file.

## Installing Feature Upgrades

The feature upgrade installation program is used to install Bottom Tracking and Waves capabilities in an ADCP.



The upgrade file is specific to the unit for which it was ordered. DO NOT attempt to install this feature for any other unit. Many feature upgrades require the latest firmware version to be installed in your ADCP. If you need to update the firmware, do this before installing the feature upgrade.


Note for included features:

**Shallow Water Bottom Track Mode 7** is included with all 1200 kHz Workhorse II ADCPs (requires Bottom Track option enabled).

**High-Resolution Water Profiling Modes** and **High Ping Rate Water Mode** are included with all 600 and 1200 kHz Workhorse II ADCPs.

**Surface Tracking** and **Lowered ADCP (LADCP) Water Mode 15** is included with all Workhorse II ADCPs.

### To install a feature update:

1. Setup the communication parameters between *TRDI Toolz* and the ADCP.
2. Wake up the ADCP by pressing the  button.
3. Click **Tools, Activate Features**.
4. Unzip the file sent by Sales or Field Service. Select the \*.Feature update file.
5. Use the **OL** command (see the Workhorse II Commands and Output Data Format guide) to verify the feature upgrade has been installed.



>OL		FEATURES
Feature		Installed
BT-HA (High Accuracy 0.4%)		Yes
Water Profile		Yes
High Resolution Water Modes		Yes
LADCP/Surface Track/WM15		Yes
Wave Gauge Acquisition		No
Shallow Bottom Mode		Yes
High Rate Pinging		Yes
Narrow Bandwidth only (WB1)		No
BT-BA (Base Accuracy 1.15%)		No

See your technical manual or contact TRDI for information on how to install additional capability in your WorkHorse.

>

## Replacing Fuses

**PIO Board.** There is one fuse on the PIO Board that protects the WorkHorse from excessive incoming power. If this fuse continues to blow, check your input power before applying power again.

To replace the fuse:

1. Turn off the power.
2. Remove the transducer head (see [Transducer Head Assembly Removal](#)).
3. The PIO board fuse is located next to the internal I/O connector. Use a small flat-blade screwdriver to open the fuse housing. Turn the end 180° (counter-clockwise) to open the fuse housing.
4. Gently pull the fuse housing out. Turn the housing to remove the fuse.
5. Check the fuse using an ohmmeter. Replace the fuse if needed with the correct voltage and amperage fuse (included in the Spare Parts kit).
6. Install the transducer head (see [Transducer Head Assembly Replacement](#)).
7. Test the system (see [Testing the WorkHorse](#)).

**External Battery Pack.** One fuse in the external battery pack protects the WorkHorse from excessive incoming power. If this fuse continues to blow, check your battery packs before connecting the external battery case again.

To replace the fuse:

1. Remove one end-cap from the external battery pack (see [End-Cap Removal Procedures](#)).
2. Carefully lift out the battery pack (attached to the end-cap).
3. Check the fuse using an ohmmeter. Replace the fuse if needed with the correct voltage and amperage fuse (included in the Spare Parts kit).
4. Install the end-cap (see [End-cap Replacement](#)).
5. Measure the voltage output of the external battery case across pin 3 (+) and pin 7 (-) on the external connector. If both battery packs are fresh, you should measure approximately +42 VDC.

**Mariner Deckbox.** The Deckbox back panel has three fuses.

- FUSE F1 - 5 Amp, 250 V, slow-blow, 5x20mm, clip-mounted. This fuse protects Deckbox circuits from input overload on J25 (20-60 VDC power input).
- FUSE F2 - 10 Amp, 250 V, slow-blow, 5x20mm, clip-mounted. This fuse protects Deckbox circuits from input overload on J26 (12 VDC power input).
- FUSE F3 - 5 Amp, 250 V, slow-blow, 5x20mm, clip-mounted. This fuse protects Deckbox circuits from input overload on J27 (98 - 264 VAC power input).

To replace the fuse:

1. Turn off power to the Deckbox.
2. Press down gently on the top edge of the fuse holder.
3. Pull the fuse holder out and down. It will extend approximately one inch. Do not attempt to remove it completely.
4. The fuse closest to the inside of the Deckbox is the fuse in use. Check the fuse using an ohmmeter. There may be a spare fuse attached to the holder. Verify that the spare fuse is the correct voltage and amperage before using.
5. Place the replacement fuse (and another spare as necessary) in the fuse holder.
6. Gently push the fuse holder back in place.
7. Turn on power and test the system (see [Testing the WorkHorse](#)).

**Mariner Deckbox Power Supply.** The Deckbox Power Supply has one fuse (F1 - 5 Amp, 250 V, fast-blow, clip-mounted). This fuse protects the Deckbox Power Supply circuits from input overload.

To replace the fuse:

1. Turn off power to the Deckbox.
2. Remove the Deckbox top cover.
3. Remove the fuse from the clips. Check the fuse using an ohmmeter. Replace the fuse if necessary with the correct voltage and amperage fuse.
4. Replace the Deckbox top cover.
5. Turn on power and test the system (see [Testing the WorkHorse](#)).

## Changing Communications Setting

A switch on the PIO board (see Figure 62, page 112) changes the communication settings between RS-232 and RS-422. Your computer and the WorkHorse must both be set to the same communication setting. Use the RS-232-to-RS-422 converter if the WorkHorse is using RS-422 communications and your computer only has an RS-232 COM port.

## Preventing Biofouling

This section explains how to prevent the buildup of organic sea life (biofouling) on the transducer faces. Objects deployed within about 100 meters ( $\approx 328$  feet) of the surface are subject to biofouling, especially in warm water. This means WorkHorse ADCP systems are subject to biofouling. Soft-bodied organisms usually cause no problems, but barnacles can cut through the urethane transducer face causing failure to the transducer and leakage into the ADCP. Therefore, you should take steps to prevent biofouling during shallow water deployments.

Some organizations may decide to use antifouling grease. However, most antifouling greases are toxic and may cause problems. Recent tests suggest antifouling grease may cause the urethane on the transducer faces to develop cracks. Warmer temperatures accelerate this effect. If using antifouling grease, remove the grease immediately after recovering the ADCP from its deployment. Remove the grease with soapy water because cleaning solvents may also cause the urethane to crack. Be sure to wear protective gloves and a face shield.

The best-known way to control biofouling is cleaning the ADCP transducer faces often. However, in many cases this is not possible.

The following options can help reduce biofouling:

- Coat the entire ADCP with antifouling paint. Make sure that the paint is applied in an even coat over the transducer faces and inductive modem (see [Applying Antifouling Paints](#)).
- ClearSignal is a clear non-toxic coating that resists biofouling because of the non-stick properties of the coating itself. For more information, see [ClearSignal Biofouling Control System \(clearsignalcoating.com\)](#).
- Apply Maringlide™ Anti-biofouling Protection Film to help prevent marine organisms, such as barnacles, from clinging to surfaces. By applying the film, biofouling is reduced, preventing surface damage to the transducer faces. This film is biocide-free.
  - 757K6181-00 - Kit, Antifouling Film, Maringlide (300/600 kHz)
  - 757K6183-00 - Kit, Antifouling Film, Maringlide (1200 kHz)

## Antifouling Paints

You can use almost any EPA approved anti-fouling paint on the housing or the urethane transducer faces. Contact the antifouling paint manufacturer for preparation and application procedures for this and other antifoulant paints. Interlux is one source of antifouling paint. Contacting this company is done with the knowledge that Teledyne RD Instruments is not recommending them, but only offering this as a source for the anti-fouling paint.

Manufacturer	Contact
Courtalds Finishes	Telephone: +1 (800) 468-7589
Interlux brand paints	Web Page : <a href="http://www.yachtpaint.com/usa/">http://www.yachtpaint.com/usa/</a>



Do not use antifouling paints that contain cuprous oxide on aluminum housings as it will cause galvanic corrosion.

## Applying Antifouling Paints

The following tips are only general recommendations. Always follow the anti-fouling paint manufacturer's instructions on how to apply the anti-fouling paint.



TRDI recommends that any antifouling coating should be applied in as thin a layer as possible. It should be understood that applying a coating may reduce the measurement range of the ADCP (though it will not affect its accuracy in the measurable range).



As originally manufactured, the transducer faces have a smooth surface which makes it inhospitable for most biofouling to develop. Preserving this smooth surface is an effective way to prevent heavy biogrowth on the transducer faces. However, if an antifouling coating is desired on the transducer faces, then the faces must be lightly abraded to allow for the antifouling coating to adhere. **As a rule, the surface must be kept smooth unless an antifouling coating will be applied.**

1. Transducer Face Surface Preparation and high pressure painted housings - Lightly abrade the surface using Scotch Brite® to remove gloss. Thoroughly clean the areas to be painted with soapy water and dry.
2. Surface Application:
  - Mask as necessary. Do not paint over mounting hardware, anodes, pressure sensors, etc.
  - Apply an even, thin layer (0.1mm, 4mil per coat) of antifouling paint. If more than one coat is needed to reach the maximum thickness, allow each coat to dry for 16 hours.

- When applying paint to the urethane faces, use extra caution to apply a smooth, thin coat of paint.



If the ADCP includes the optional pressure sensor, do not block the sensor port. The sensor port is a small hole in the center of the copper screw (see Pressure Sensor Maintenance). During anti-fouling paint application, tape off the screw. Once the anti-fouling paint has cured, remove the tape.

This means that the sensor port is not fully protected from bio fouling. Even though the sensor port is surrounded by the antifouling paint, bio fouling may still build up on the copper screw and eventually clog the sensor port. However, most organisms do not seem to find the small amount of unpainted surface attractive. If it is logistically possible to periodically inspect/clean the pressure sensor port, it is highly recommended. This tradeoff situation must be analyzed for individual deployments. Unfortunately, the location of the deployment site usually dictates action in this regard.



**Figure 58. Antifouling Paint Applied to a WorkHorse Sentinel**

## Removing Biofouling

To remove foreign matter and biofouling:

1. Remove soft-bodied marine growth or foreign matter with soapy water. Waterless hand cleaners remove most petroleum-based fouling.



Do not use power scrubbers, abrasive cleansers, scouring pads, high-pressure marine cleaning systems or brushes stiffer than hand cleaning brushes on the transducer faces. The urethane coating on the transducer faces could be damaged.

If there is heavy fouling or marine growth, the transducer faces may need a thorough cleaning to restore acoustic performance. Barnacles do not usually affect ADCP operation, but TRDI does recommend removal of the barnacles to prevent water leakage through the transducer face. Lime dissolving liquids such as Lime-Away® break down the shell-like parts. Scrubbing with a medium stiffness brush usually removes the soft-bodied parts. Do NOT use a brush stiffer than a hand cleaning brush. Scrubbing, alternated with soaking in Lime-Away®, effectively removes large barnacles.



If barnacles have entered more than 1.0 to 1.5 mm (0.06 in.) into the transducer face urethane, you should send the ADCP to TRDI for repair. If you do not think you can remove barnacles without damaging the transducer faces, contact TRDI.

2. Rinse with fresh water to remove soap or Lime-Away® residue.
3. Dry the transducer faces with low-pressure compressed air or soft lint-free towels.



Always dry the ADCP before placing it in the storage case to avoid fungus or mold growth. Do not store the ADCP in wet or damp locations.

## Zinc Anode Inspection and Replacement

High-pressure systems have up to twelve sacrificial zinc anodes. If the ADCP does not have exposed bare metal, properly installed anodes help protect the ADCP from corrosion while deployed. Read all instructions before doing the required actions.

### Zinc Anode Inspection

The life of a zinc anode is not predictable. An anode may last as long as one year, but dynamic sea conditions may reduce its life. Use a six-month period as a guide. If the total deployment time for the anodes has been six months or more, replace the anodes. If you expect the next deployment to last six months or more, replace the anodes.

To inspect the anodes:

1. Inspect the anodes on the transducer assembly, housing and end-cap for corrosion and pitting. If most of an anode still exists, you may not want to replace it.
2. Inspect the RTV-covered screws that fasten each anode. If the RTV has decayed enough to let water enter between the screws and the anode, replace the RTV.
3. If you have doubts about the condition of the anodes, remove and replace the anode.

### Zinc Anode Electrical Continuity Check

Check electrical continuity using a digital multi-meter (DMM). Scratch the surface of the anode with the DMM probe to make good contact if the anode is oxidized. All measurements must be less than five ohms. If not, reinstall the affected anode.

**End-Cap Anode.** Measure the resistance between all four anodes.

**Housing Anodes.** Measure the resistance between all four anodes.

**Transducer Anode.** Remove the housing. Measure the resistance between the anode and any one of the four screws holding the PC boards to the transducer.

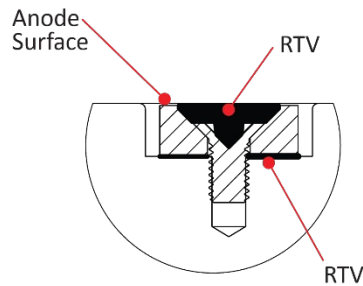
### Zinc Anode Replacement

To remove and replace the zinc anode/s:

1. Remove the RTV from the anode screw heads. Remove the screws.
2. The anode may stick to the ADCP because of the RTV used during assembly. To break this bond, first place a block of wood on the edge of the anode to protect the housing anodizing and paint. Carefully strike the block to loosen the anode.
3. Clean the bonding area under the anode. Remove all foreign matter and corrosion. Apply a continuous 1 to 2 mm bead (0.04-0.08 in.) of RTV around each screw hole.
4. Set a new anode in place and fasten with new screws.
5. Fill the counter bore above each screw head with RTV. The RTV protects the screw heads from water and prevents breaking the electrical continuity between the anode, screw, and housing.



Do not cover the top surface of the anode with RTV. The anode must contact seawater.



6. Check the electrical continuity. If any measurement is greater than one ohm, reinstall the affected anode.

**Do not connect other metal to the ADCP. Other metals may cause corrosion damage. Use isolating bushings when mounting the ADCP to a metal structure.**



Do not use zinc anodes with an iron content of more than 0.0015%. The major factor controlling the electrical current output characteristics of zinc in seawater is the corrosion film that forms on the surface of the zinc. Corrosion product films containing iron have a high electrical resistance. As little as 0.002% iron in zinc anodes degrades the performance of the anode.

Do not use magnesium anodes. Magnesium rapidly corrodes aluminum housings.

## Protective Coating Inspection and Repair

TRDI uses paint on the high pressure housing for identification and corrosion protection. For more protection, the case and the transducer assembly are first anodized per MIL-A-8625, Type 3, Class 1 and sealed with sodium dichromate. Do not damage the surface coatings when handling the ADCP.

Inspect the end-cap, housing, and transducer assemblies for corrosion, scratches, cracks, abrasions, paint blisters, exposed metal (silver-colored aluminum), exposed anodize (black or dark green), and exposed primer (light blue or yellow for 6000 meter systems). **Be critical in your judgment; the useful life of the ADCP depends on it.**



The procedures contained in this section apply to our standard aluminum systems. For systems made of other materials, contact TRDI. Read all instructions before doing the required actions.



The chemicals used in the following steps can be hazardous to your health. Read all material safety data sheets and manufacturer's instructions before handling these chemicals.



If there is any damage to the paint near the edges of the urethane transducer cups or the I/O connector, **DO NOT DEPLOY THE ADCP**. Return the WorkHorse to TRDI for repair.

To repair or touch up the protective paint:

1. Remove all loose paint without damaging the anodizing. Clean and prepare the damaged area using a fine-grade abrasive cloth. Feather the edges of the paint near the damaged area. Try to have a smooth transition between the paint and the damaged area. Do not sand the anodized area. If there is damage to the anodizing, return the ADCP to TRDI for repair.
2. Clean the area with alcohol. Do not touch the area after cleaning.
3. Mix the epoxy primer Part A and Part B using a 1:1 mix. Paint one coat of epoxy primer (see note below). Allow the primer to dry thoroughly before continuing.

- Mix the colored paint using two parts color and 1 part catalyst. Paint with one coat of colored paint (see note below).



The catalyst (hardener) will rapidly harden in air. Mix only the amount of paint you need and work quickly.

TRDI uses two-part epoxy type paint. This paint is manufactured by Sherwin –Williams Proline Paint Store, 2426 Main St., San Diego, CA, 92113-3613, Telephone: +1 (619) 231-2313.

Primer Manufacturer's part numbers:

F-158 for 6000 meter systems (part A and part B)

3061 for all other systems (part A and part B)

Colored paint Manufacturer's part numbers:

4800HS, Catalyst,

4800-19, Yellow

4800-28, Orange

4800-01, Snow White

4800-25, Bright Blue

Contact the paint manufacturer for preparation and application procedures for this and other paints. Contacting this company is done with the knowledge that Teledyne RD Instruments is not recommending them, but only offering this as a source for the paint.



# Installing the Workhorse II Spare Boards Kit

This section shows how to install the Workhorse II board stack. The Spare Boards Kit has been set up so that you will replace all the boards at once. This is done so that you do not have to risk damaging the individual boards while swapping in individual boards and maintains all calibrations between boards.



Before handling either the Spare Board Kit or the original board set, always wear an earth-grounding static protection strap. The electronics in the Workhorse II are very sensitive to static discharge. Static discharge can cause damage that will not be seen immediately and will result in early failure of electronic components.

TRDI assumes that a qualified technician or equivalent will perform all the following work.

**Do not swap individual boards between ADCPs.** Each board has individual serial numbers and calibrations that work as a set. This cannot be replicated in the field.

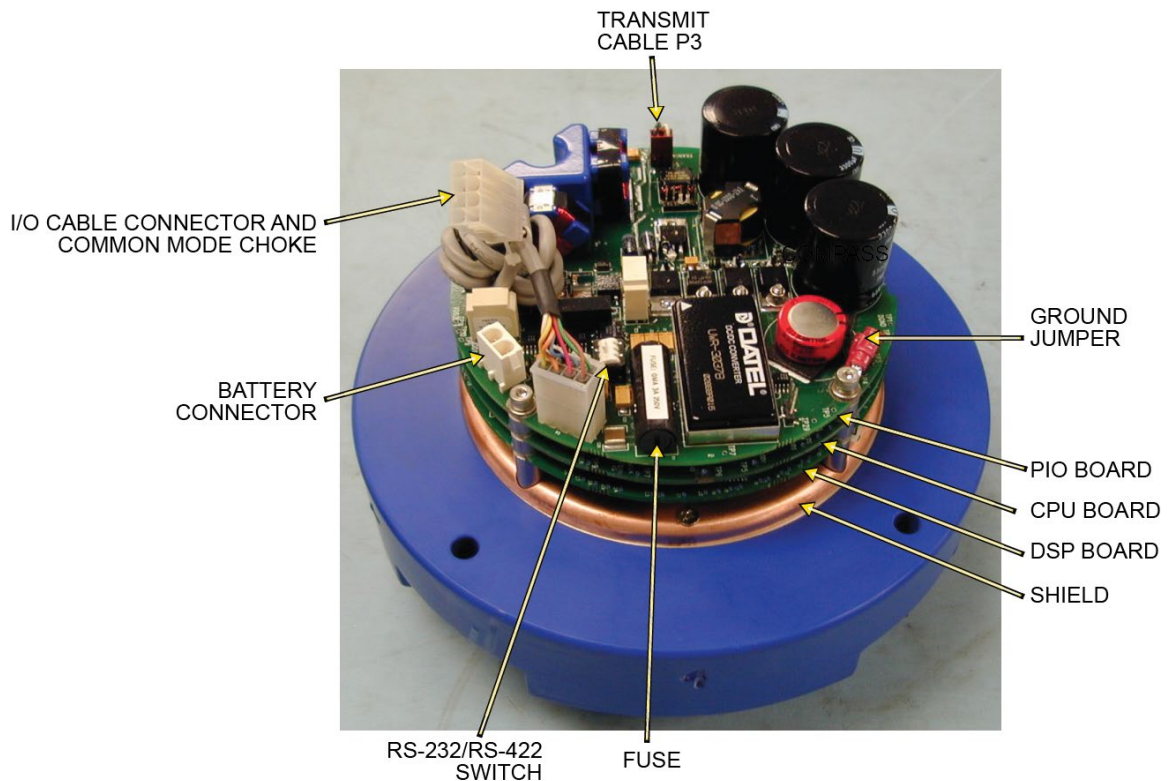


```

PS0                                     (example shown for a WHII board stack)
↓
Board Serial Number Data:
  57 00 00 03 8F 26 DB 23 WHP727-2022-03A
  06 00 00 03 D4 C2 F9 23 PIO727-3023-13B
  07 00 00 08 D9 09 58 09 REC727-1000-03F
↓
ISM serial number: 030000E3 23D7E86F
    
```

**The receiver board is not field replaceable.** The pressure sensor factory calibration is set on this board and cannot be replicated in the field.

The Spare Boards Set will allow your system to perform to the same velocity specifications as your original set. However, you must perform the Compass Calibration procedure after the installation of the batteries.



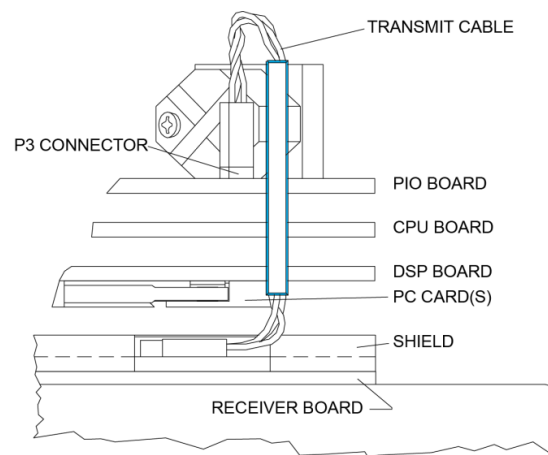
**Figure 59. Original Workhorse Board Stack**

## Remove the Original Set of Boards

### To remove the original boards:

1. Remove the Transducer assembly from the pressure case. Refer to [Transducer Head Assembly Removal](#) for instructions.
2. With your earth-ground static protection strap on, use a 3mm Allen wrench to remove the four bolts that secure the original boards to the Transducer assembly.
3. Note the orientation of the transmit cable connector as it is plugged into the PIO board and to the Receiver board (see Figure 60).

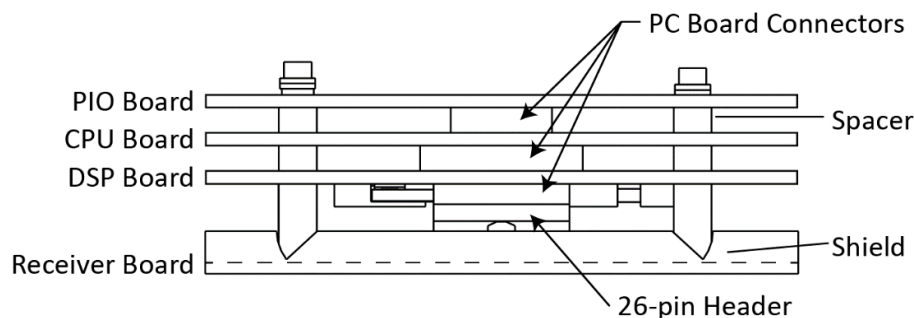
This cable must be removed, and it has a very tight fit. To remove this cable, lift straight up on the boards and tilt slightly (no more than 2 cm) toward the cable. This should allow you enough slack to unplug the cable from the PIO board. If this is not possible you may unplug the cable from the Receiver board. Be sure to note its orientation before unplugging.



**Figure 60. Transmit Cable**

4. Once the transmit cable has been disconnected you may now remove the PIO and WHP boards as a set by lifting them straight up.

These top three boards are connected to each other via connectors and will remain as one piece (see Figure 61). The DSP board connects to the Receiver board through a 26-pin header. The 26-pin header is a series of male pins. The 26-pin header may or may not stay connected to the DSP board when you remove the top three boards. If you see that there are male pins sticking out of the DSP board when you finish removing the board set, then the header has remained attached to the DSP board. If this happens remove it and place it into the Receiver board. To remove it, gently rock it back and forth while pulling it away from the DSP board. Once removed, align it with the connector on the Receiver board and press it into place.

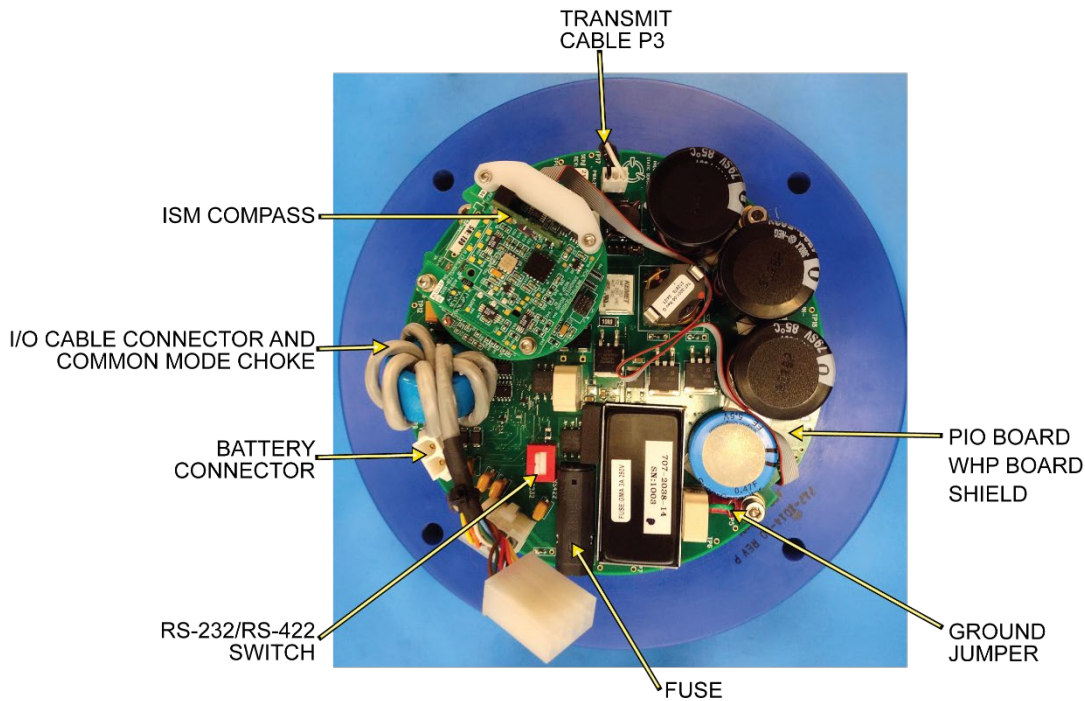


**Figure 61. PC Board Connectors**

5. Remove all PCMCIA cards from the original set of boards and keep for use in other ADCPs. They cannot be used in the Workhorse II system as this uses a CompactFlash card.
6. Set the original board set to the side for now.

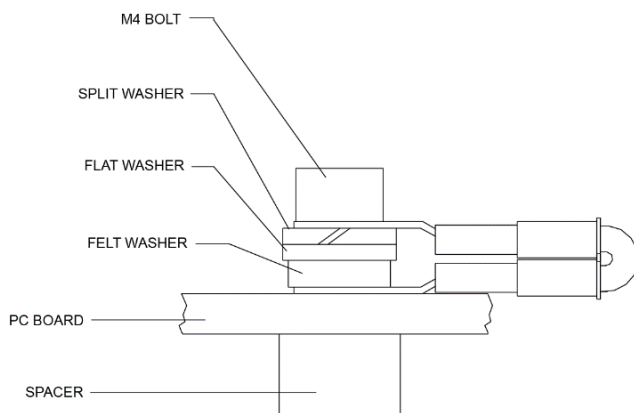
**To install the Workhorse II board kit:**

1. With your earth-ground static protection strap on, remove the Workhorse II Board Kit from the anti-static bag.

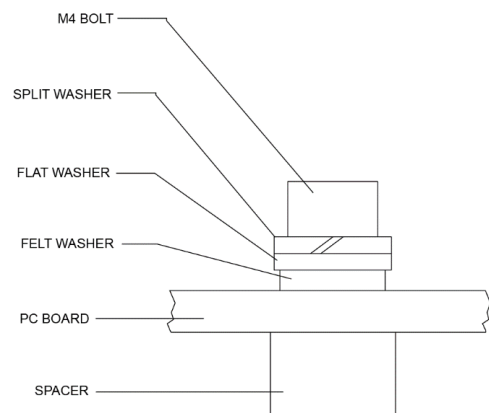


**Figure 62. Workhorse II Board Stack**

2. Remove the four brass thumbnuts from the M4 bolts that secure the spare board set together. You will be using these bolts to secure the boards in your system. **DO NOT** change the position of any of the bolts. The bolts containing the felt washers and ground jumper must remain in the same position (see Figure 63 and Figure 64).



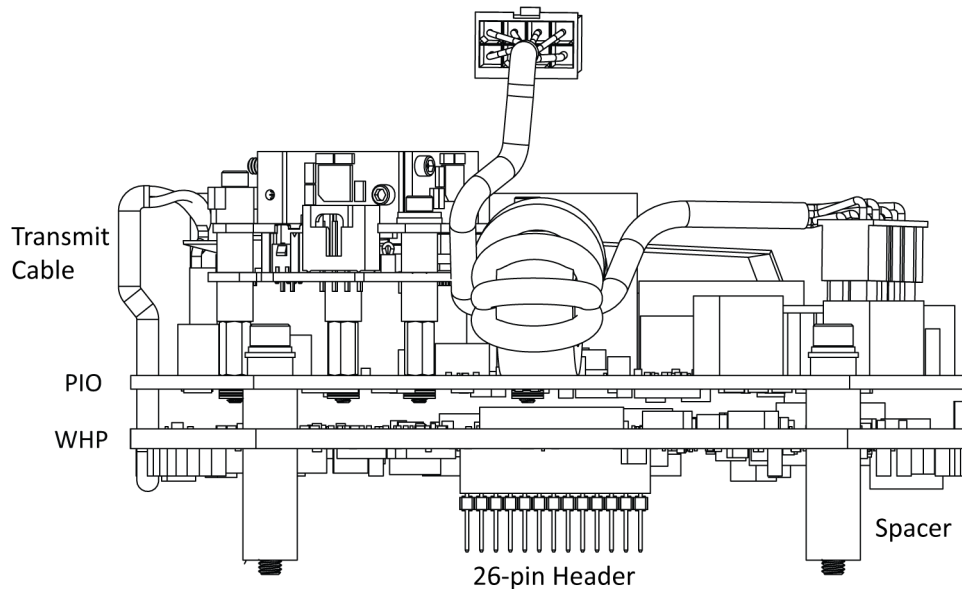
**Figure 63. Ground Jumper**



**Figure 64. Mounting Hardware**

3. Place the thumbnuts (just removed in step 3) on the four bolts of your original set of boards and then place the boards into the anti-static bag.

4. Connect the spare board stack to the Receiver board. Align the boards to the 26-pin header connected to the Receiver board. As you connect the board stack, connect the transmit cable to the Receiver PCB in the same orientation as was installed on the original board set.



5. Tighten the four M4 bolts to 1.20 N.m. (10.6 In-LB).
6. Check the CompactFlash Memory Card is fully seated into the connector located on the WHP PCB.
7. Check the communication switch is set to RS-232 or RS-422 as needed.
8. Check the ISM cable connector is fully seated into the connector on the WHP PCB.
9. [Install the Transducer into the Pressure Case](#). Use new O-Rings and desiccant.

## Installing the Beam Cosine Matrix

The beam cosine matrix table corrects small transducer beam misalignment angles that occur during manufacturing. Contact TRDI Field Service to have the file emailed to you. This file may be pre-installed if the ADCP serial number was known when the board stack was ordered.



**Do not swap individual boards between ADCPs. Each board has individual serial numbers and calibrations that work as a set. This cannot be replicated in the field.**

### To install the beam cosine matrix:

1. Connect the ADCP I/O cable and apply power.
2. Start *TRDI Toolz* and confirm that the Workhorse II ADCP is communicating normally.
3. Run the script file *xxxx BEAM COSINE MATRIX.txt* (where *xxxx* is your system serial number). The Beam Cosine Matrix table will automatically be updated. You can verify the beam cosine matrix loaded by viewing the PS3 results under the label Q14.

```
>ps3
↓
Instrument Transformation Matrix (Down):   Q14:
1.4691   -1.4705   0.0078   -0.0067   24069   -24092   127   -109
-0.0068   0.0078   -1.4618   1.4606   -111   127   -23950   23930
0.2663   0.2657   0.2657   0.2661   4363   4354   4353   4359
1.0367   1.0350   -1.0359   -1.0374   16985   16957   -16972   -16996
Beam Angle Corrections Are Loaded.
>
```

## Installing the Pressure Sensor Coefficients

If the ADCP included a pressure sensor, the pressure sensor coefficients must be loaded. Contact TRDI Field Service to have the file emailed to you. This file will be pre-installed if the ADCP serial number and/or original pressure coefficients were known when the board stack was ordered.



**The receiver board is not field replaceable. The pressure sensor calibration is set on this board and cannot be replicated in the field.**

### To install the Workhorse II pressure sensor coefficients:

1. Connect the ADCP I/O cable and apply power.
2. Start *TRDI Toolz* and confirm that the Workhorse II ADCP is communicating normally.
3. Run the script file *xxxxx WH2 PRESSURE SENSOR COEFFICIENTS.txt* (where *xxxx* is your system serial number) to install the pressure sensor coefficients appropriate to the system. The Pressure coefficients will automatically be updated. You can verify the pressure sensor coefficients loaded by viewing the PSO results.

```
>ps0
↓
Pressure Sens Coefficients:
      c3 = +2.1725004E-212
      c2 = +2.013757E-08
      c1 = +1.264614E-01
      Offset = +0.000000E+00
↓
>
```



Remember to send the AZ command to zero the pressure sensor prior to putting the ADCP in water.

## Testing the System After Board Replacement

### To test the system after replacing the boards:

1. Connect the I/O cable and power and test the ADCP as shown in [Chapter 5, Testing the Workhorse II](#). All PA tests should pass when run in water and the PC tests should pass with the ADCP out of water.
2. To test that the transmit cable is connected properly, run the PT4 test. The test failure example shown below is what you would see for a missing or improperly attached transmit cable.

```
[BREAK Wakeup A]
Workhorse II Broadband ADCP Version 77.xx
Teledyne RD Instruments (c) 1996-2021
All Rights Reserved.
>pt4

IXMT   =      0.0 Amps rms [Data= 0h]
VXMT   =     19.3 Volts rms [Data=4ch]
Z      =     999.9 Ohms
Transmit Test Results = $C0 ... FAIL
>
```

3. Perform a field calibration of your ISM compass (see [WHII ISM Compass Calibration](#)).
4. Format the CompactFlash Memory Card (see [Formatting the CompactFlash Memory Card](#)). You have completed the Workhorse II Spare Board Installation.
5. If the ADCP included optional feature upgrades, verify the features are installed by sending the OL command. If the features were not pre-installed, contact TRDI Field Service to have the file emailed to you. See [Installing Feature Upgrades](#) for instructions.

# Replacing the End Cap Connector

This section explains how to replace the 7-pin end-cap connector on a Workhorse or external battery.



Some older WorkHorse end-caps may have the connector brass lock nut glued into place. If this is the case for your end-cap assembly, TRDI recommends that you purchase a new end cap assembly.

## Equipment Provided

The WorkHorse End-Cap Tools Kit (P/N 757K6122-00) includes the following:

- Socket, lock nut removal
- Extracting wrench
- Plug, dummy, modified



The End Cap Replacement Kit P/N 757K6123-00 (200 and 500 meter systems), 757K6125-00 (6000 meter systems), and 757K6149-00 (WorkHorse External Battery case) includes the following:

- 7-pin end-cap connector with cable and 2-014 O-ring
- Isolation bushing and 2-017 O-ring (metal end-caps only)
- Connector, header, 8-pin Molex or 2-pin as needed
- Fuses and fuse holders, wire, shrink tube (External Battery kit only)
- Nut, brass
- End-cap O-ring(s)
- Desiccant
- Silicon lubricant, 4-pack
- Loctite® 242
- Cord, lacing, black

## Customer Supplied Additional Equipment

- Soft pad (ESD Safe) to rest WorkHorse on while disassembling and reassembly
- Socket wrench handle
- Torque Wrench (35 Inch/pound / 4 N-M)
- Multi-Meter



## Removing the End-Cap Connector

To remove the end-cap connector:

1. Remove the end-cap from the housing.
2. Insert the modified dummy plug into the connector.



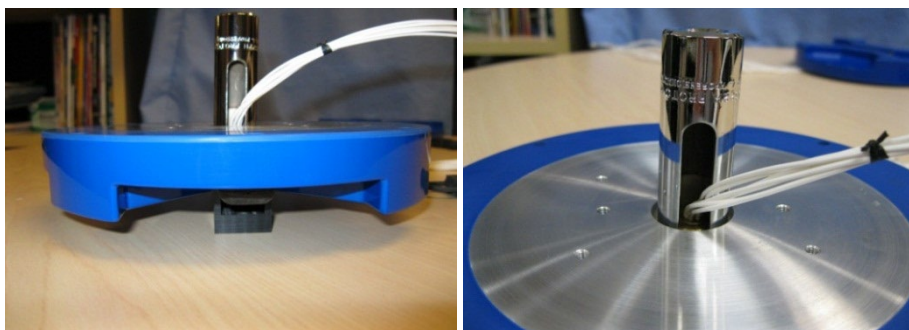
**Figure 65. Modified Dummy Plug**

3. Place the Extracting Wrench over the connector and dummy plug. The wrench will fit into the End Cap slot.



**Figure 66. Extracting Wrench**

4. Flip the end-cap assembly over and insert the socket onto the lock nut. Slide the cable wires into the socket's clearance slot.



**Figure 67. Lock Nut Removal Socket**

5. Attach a ratchet wrench to the socket and remove the lock nut.





**Figure 68. Removing the Connector**

- Remove the Molex 8-pin header connector by cutting the wires approximately 3-inches from the connector. Remove the connector from the end-cap.



USE CAUTION – do not score or scratch the O-ring seal bore.

- Remove all the tools and clean the end-cap thoroughly with Flux-Off® cleaner (or similar product). The O-ring pocket must be free of dirt, burrs, and divots.



Replace the end cap if any burrs or divots are found. These could provide a leakage path into the ADCP housing.

## Installing the New End-Cap Connector

To install the new connector:

- Clean the connector threads with Flux-Off® cleaner (or similar product).
- Apply a **light** coat of silicon lubricant onto the O-rings (P/N 2-014 and 2-017).

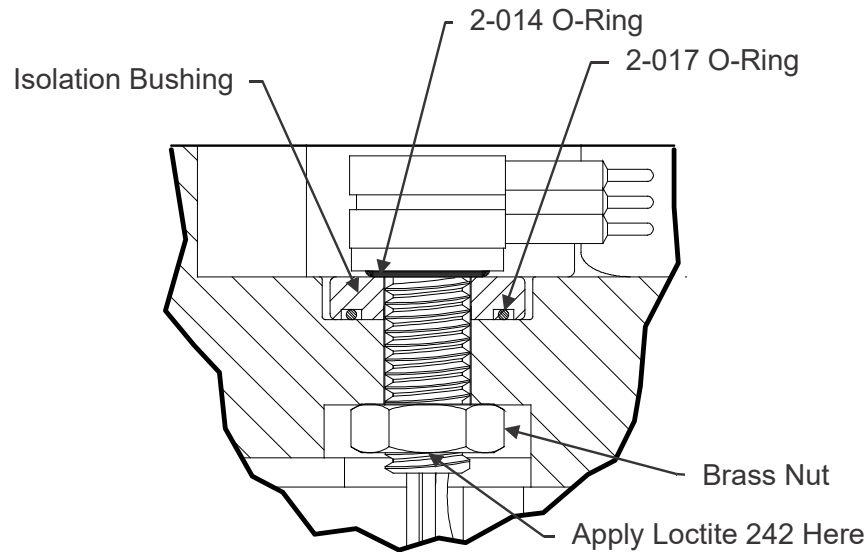


Do not over lube the O-rings.

- Systems with a metal end-cap use an isolation bushing and 2-017 O-ring between the end-cap and the 7-pin connector. Press the new bushing and O-ring onto the end-cap as shown in Figure 69.



Carefully check metal end-caps for signs of corrosion such as white deposits. If corrosion caused part of the end-cap to be visibly damaged, do not redeploy your system. Send it back to TRDI for inspection.



**Figure 69. End-Cap Connector with Isolation Bushing**



The isolation bushing and 2-017 O-ring are required for metal end-caps only.

4. Install the O-ring onto the face seal groove located at the bottom of the threads on the connector.



Do not scratch or mar the O-ring surface as you feed it over the threads of the connector.

5. Install the modified dummy plug. Pay attention to the pin orientation. **Do not bend the pins.**
6. Apply one drop of Loctite® 242 on the top starting threads of the connector.
7. Install the connector into the end cap by feeding the 7 wires and pins through the end-cap from the outside face (see Figure 65. Modified Dummy Plug).




The connector pins should point away from beam 3.

8. Push the connector down so that it fully bottoms out in the O-ring pocket.



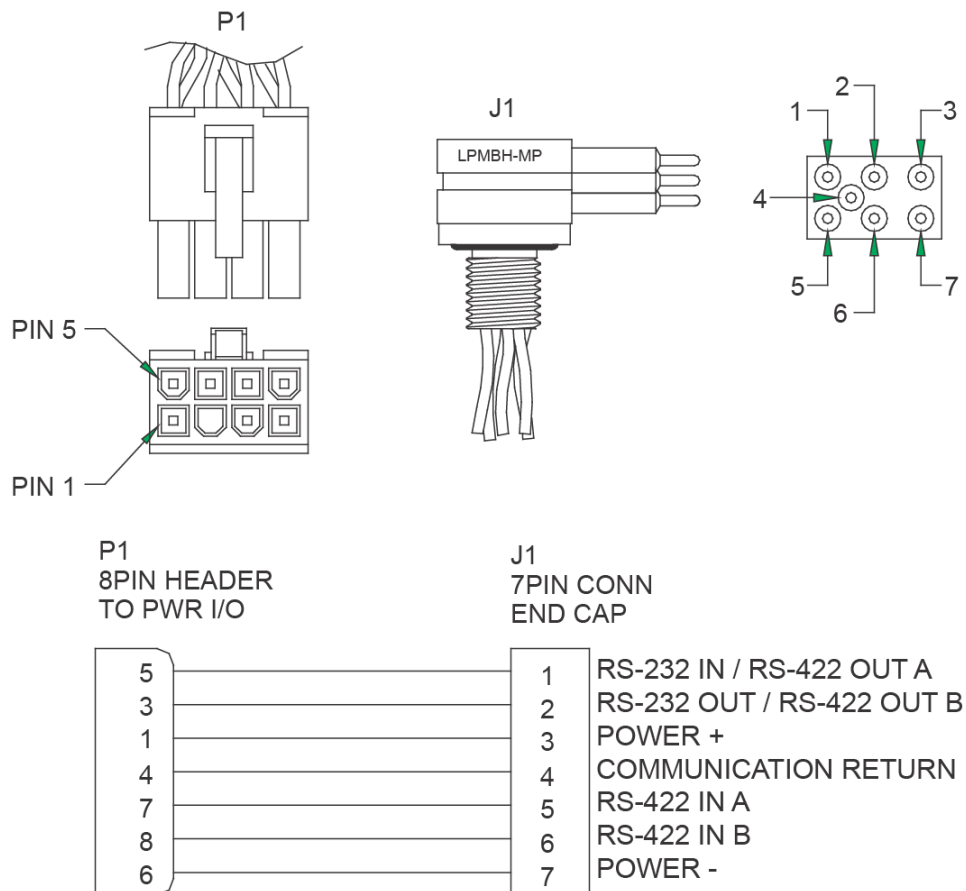
Do not score or scratch the bore or the O-ring pocket sealing face.

9. Feed the brass nut through the wires and pins and hand tighten onto the connector threads.
10. Place the Extracting Wrench over the connector and dummy plug. The wrench will fit into the End Cap slot between the 2 rails (see Figure 66. Extracting Wrench).
11. Flip the End-Cap assembly over and insert the slotted socket onto the lock nut. Fit the cable wires into the socket's clearance slot (see Figure 67. Lock Nut Removal Socket).
12. Attach a torque ratchet wrench to the socket and tighten the nut to 35 in/lbs., (4 NM). **Make sure that the connector is aligned straight and is parallel to the rails.**
13. Remove the assembly tools and the dummy plug.
14. Follow the wiring schematic in order to assemble the Molex 8-pin header connector or external battery case wiring (see [Wiring Diagrams](#)). Insert the pins into the connector. As the pin is pushed into the connector, the tabs on the pin will lock it into place.

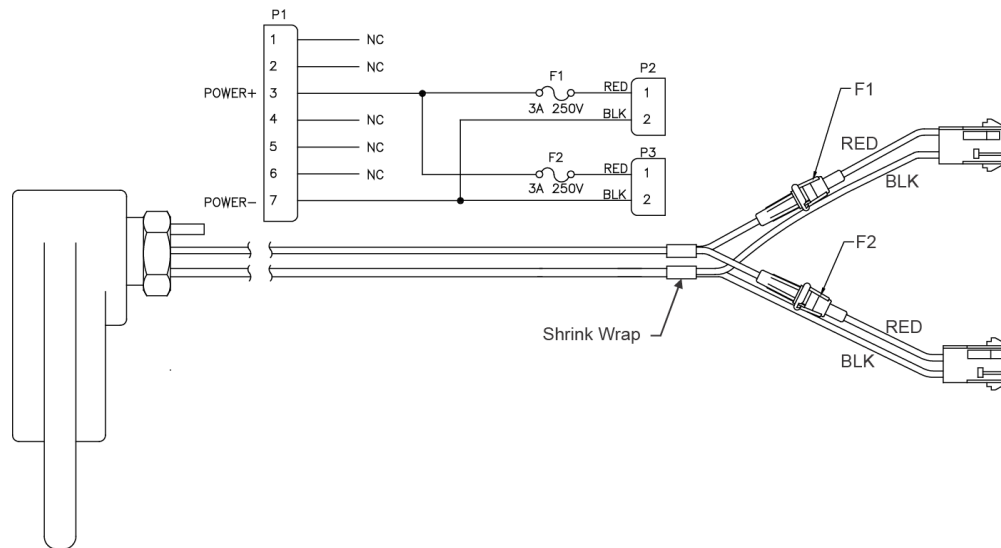
 Use the old cut-off Molex connector as a reference in addition to the schematic diagram when installing the new Molex connector. Each wire should have a corresponding J1 pin number tag.

15. After all the pins for the connector are installed, use a multi-meter to confirm that the connector has been wired properly by performing an end-to-end continuity check.
16. Use the black lacing cord to bind the connector wires together. The lacing is applied by wrapping it around the wire bundle approximately four times and then tying it securely with a square knot. Each wrap on the wire bundle should be spaced approximately 3-inches apart. This will prevent the wires from “bird caging” out and getting caught between the end-cap and pressure case O-ring.
17. For the WorkHorse External Battery Case, cut the wires on pins 1, 2, 4, 5, and 6 to 6mm long. Shrink wrap the bare ends of the wires. Place shrink wrap around the splices on pins 3 and 7 (see Figure 71. WorkHorse External Battery Case Wiring).

## Wiring Diagrams



**Figure 70. End-Cap Connector Wiring – WorkHorse ADCP**



**Figure 71. WorkHorse External Battery Case Wiring**



Cut the wires on pins 1, 2, 4, 5, and 6 to 6mm long. Shrink wrap the bare ends of the wires. Place shrink wrap around the splices on pins 3 and 7.

## Replacing the CPU Lithium Battery



This section applies to the original WH electronics only. See [How do I know if I have WH or WHII electronics?](#) to determine what electronics are installed in the system.

This section explains how to replace the rechargeable lithium coin-cell battery in a WorkHorse system. The battery is located on the CPU board just below the PIO board transmit capacitors. The battery will recharge itself as soon as power is applied to the ADCP. Over time, the battery loses the ability to recharge and the voltage capacity drops. Therefore, TRDI recommends replacing the battery every five years.



The battery keeps the Real-Time Clock (RTC) running in case power is removed temporarily. The RTC drifts independently from the battery voltage by approximately 12 minutes/year. Clock drift does NOT indicate problems with the battery.

### **Equipment Required**

- ESD safe work space
- Soft pad (ESD Safe) to rest WorkHorse on while disassembling and reassembly
- Anti-static ground strap
- Hex wrenches
- O-rings and desiccant for ADCP
- Soldering iron
- Digital multi-meter
- Lithium battery VL2330

To check for a failing lithium battery:

1. Charge the lithium battery by powering the system using external power and use *TRDI Toolz* to send the PC2 command to prevent the ADCP from sleeping. Let the system run for three hours.
2. Send the TS command and set the clock.
3. Remove all power to the system and wait at least 6 hours (two days is recommended). If you don't want to wait several days, [remove the transducer head assembly](#). On the PIO board short TP10 (GND) to TP11 (VDD2) for 10 seconds using a jumper wire. Remove the jumper.
4. Power up the system and send the TS? command to verify the system time. If the time has reset to January 1, 2000 or is significantly incorrect, then you should verify the lithium battery voltage.

## Testing the Lithium Battery Voltage

To verify that the lithium battery voltage:

1. Charge the battery by powering the system using external power and send the PC2 command to prevent the ADCP from sleeping. Let the system run for three hours.
2. Remove all power from the ADCP. [Remove the transducer head assembly](#).



Wait a few minutes after turning the power off before removing the electronics stack. This allows the transmit capacitors on the PIO board time to discharge.

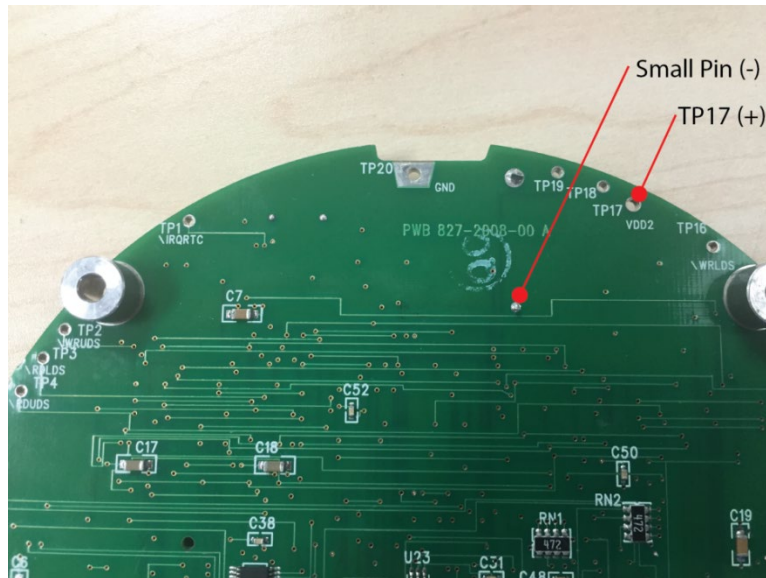
3. Attach an earth-grounded wrist strap.



Before handling any of the WorkHorse boards, you must be sure that you always wear an earth-grounding static protection strap. The electronics in the WorkHorse are very sensitive to electro-static discharge (ESD). **ESD can cause damage that will not be seen immediately and will result in early failure of electronic components.**

4. Remove the CPU board from the main electronic stack (see [Installing the Spare Boards Kit](#)).
5. Measure the voltage on the CPU board between TP17 (BAT+) and the small pin on the battery located on the back side of the CPU board (GND) (see Figure 72).
6. The voltage should hold stable at approximately 2 to 3 VDC for several hours at least, but for best results it should hold at 3 VDC for several days.

7. If the voltage is not holding for more than a week, then the battery may be defective. Before continuing, review your options:
  - Replace the Lithium battery yourself.
  - If you are uncomfortable with replacing the battery, please contact [TRDI Customer Service Administration](#) to schedule a replacement of the battery or request a Return Merchandise Authorization (RMA) directly from our website <[here](#)>.



**Figure 72. Lithium Battery Test Points on the CPU Board**

## Replacing the Lithium Battery

To replace the battery:

1. While wearing an earth-grounded wrist strap, locate the lithium battery B1 (on the top side of the CPU board).
2. De-solder the two associated pins for B1 which are located on the underside of the CPU board.
3. Install the new battery assembly (VL2330). Please note the battery pins; the battery can only be installed one way.



**Figure 73. Lithium Battery**

4. Verify the voltage holds stable at approximately 3 VDC (see [Testing the Lithium Battery Voltage](#), step 2).
5. [Replace the transducer head assembly](#). Make sure to use new O-rings and desiccant.

# Mariner I/O Cable Dry End Connector Assembly

The Mariner I/O cable connects the transducer assembly to the Deckbox. This cable is typically pulled through the vessel inside of conduits that may be unable to accommodate the dry end connector. To facilitate installation through conduits, the cable is provided without the dry end connector installed. Once the cable has been pulled through the vessel, the dry end connector is installed. The following procedure explains the steps required to install the dry end connector.

## Tools and Equipment Requirements

- WorkHorse Mariner ADCP I/O cable pigtail kit (dry end in bag)
- 24-pin dry end cable connector (Part Number 85106RC2024P50) with pins

## Tools and Equipment Requirements (User Supplied)

- Standard wire strippers for 18 - 22 awg wire.
- Heat Gun
- 6 inches of 0.500 inch (12.7 mm) general purpose heat shrink tubing
- Wire cutters
- Multi-meter

The following items can be purchased from:

Daniels Manufacturing Corporation  
526 Thorpe Road  
Orlando, FL 32824  
Phone: (407) 855-6161  
Web Site: [www.dmctools.com](http://www.dmctools.com)

- Crimping tool: AF8 M22520/1-01
- Turret Head TH1A: M22520/1-02



May be purchased as a pair AF8-TH1A Crimp Tool with TH1A Turret Head.

- Extraction Tool: MS24256R20 (DRK20)
- Insertion Tool: MS24256A20 (DAK20)



# Installation Instructions

To install the dry end cable connector:

1. Strip the black polyurethane jacket back approximately 40 mm (1.5 inch).
2. Slide on a 76.2 mm (3 inch) length of heat shrink tubing. Using a heat gun, shrink the tubing around the end of the cable. Add a second layer of heat shrink tubing to strengthen the cable.
3. Remove the cable clamp and rubber grommet from the connector. Slide the grommet onto the cable.
4. Strip back the insulation on the wires approximately 6 mm (0.25 in.).
5. Insert the wire into the pin's crimp barrel and ensure that it has penetrated correctly by checking that it may be seen through the lateral hole in the barrel. Using the crimping tool, crimp a pin on each wire. Squeeze the crimp tool handles firmly until a click is heard. The crimp tool should spring open when released.



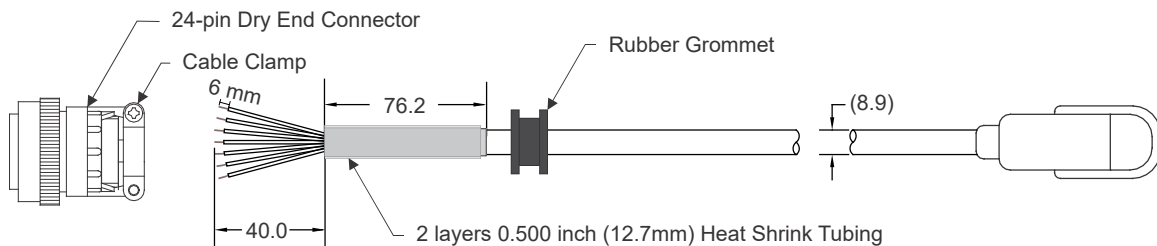
Do not solder the wires as this will cause the pin to be deformed and it will not fit into the connector.

6. Repeat step 5 for each of the wires.
7. Insert the pins in the connector using the insertion tool (MS24256A20 (DAK20)). The pin out configuration is shown in Figure 20, page 32.



Insert the pins from the center of the connector and work your way out. This makes it less likely to bend or break the wires off of the pins.

8. Slide the rubber grommet over the heat shrink tubing and onto the cable clamp. Insure the cable clamp and rubber grommet will grip the cable's black polyurethane jacket (covered with the two layers of heat shrink tubing), not the single wires.
9. Attach the loose half of the cable clamp over the rubber grommet using the two screws.



**Figure 74. Mariner I/O Cable Construction**

## Checking the Wiring

After the connector is installed, use a multi-meter to confirm that the connector has been wired properly by performing an end-to-end continuity and adjacent pin isolation check (see Figure 20. Mariner I/O Cable Wiring, page 32).

1. Confirm that all pins in the dry end connector are not shorted. Check for  $>2$  Mohms of resistance between each of the dry end pins.
2. Using a 2-inch jumper wire (such as a paper clip) connect pins 1 and 2 of the wet end connector. Confirm that the associated dry end pins are shorted together. The resistance should nominally be 0.033 Ohms per meter of cable conductor at 20°C. For example, a 30 meter cable has a nominal conductor resistance of 1 Ohm at 20°C. The total resistance should be  $0.033 \times 30 \times 2$  conductors = 1.98 Ohms.
3. Move the jumper to pins 1 and 3 of the wet end connector and confirm that pins 1 and 3 are wired properly.
4. Repeat step 3 for each of the remaining pins in the wet end connector. Each time, use pin 1 as the reference and then the other pin will be the pin that has not been tested.

# Chapter 5

## TESTING THE WORKHORSE



In this chapter, you will learn:

- Testing the WorkHorse
- Test Results
- Dock Side Tests
- Sea Acceptance Tests

This chapter explains how to test the WorkHorse using *TRDI Toolz*. These tests thoroughly check the WorkHorse in a laboratory environment, but are no substitute for a practice deployment. You should test the WorkHorse:

- When you first receive the WorkHorse.
- Before each deployment or every six months.
- When you suspect instrument problems.
- After each deployment.

These test procedures assume all equipment is working. The tests can help you isolate problems to a major functional area of the WorkHorse. For troubleshooting information, see [Troubleshooting](#).



For stationary deployments, the *TRDI Toolz* tests are the only tests required to verify the ADCP is operating correctly. When the ADCP is mounted to a moving vessel, use the Dock Side tests and the Sea Acceptance tests.




Refer to the [Workhorse and Workhorse II Command Guide](#) for a listing of all direct commands and their format.



## Testing the Workhorse II with *TRDI Toolz*

### To test the ADCP:

1. Setup the communication parameters between *TRDI Toolz* and the ADCP.
2. Wake up the ADCP by pressing the  button.
3. On the **Tools** menu, select **Script Editor**.
4. Click the **Open** icon and select the *TestWH.txt* file.



The script file *TestWH.txt* is included with *TRDI Toolz* version 1.4.0.3 or higher. A copy of it is shown in the *TRDI Toolz* help file and can be copy/pasted into the script editor window.

## Time Set

The script file will send the ADCP the **TS?** command. This will show the current setting of the real time clock. For example;

```
>TS?
TS = 22/06/17,07:31:27 --- Time Set (yr/mon/day,hour:min:sec)
>
```

## Display System Parameters

The script file will send the **PS0** command. This tells the ADCP to display specific information about your ADCP. For example, a system with an ISM compass will show:

```
>ps0
Instrument S/N: 0
  Frequency: 614400 HZ
  Configuration: 4 BEAM, JANUS
  Match Layer: 10
  Beam Angle: 20 DEGREES
  Beam Pattern: CONVEX
  Orientation: UP
  Sensor(s): ISM DEPTH TEMPERATURE PRESSURE
Pressure Sens Coefficients:
  c3 = +0.000000E+00
  c2 = +0.000000E+00
  c1 = +8.240925E-02
  Offset = +0.000000E+00

Temp Sens Offset: -0.13 degrees C

  CPU Firmware: 77.00z Prototype
  Boot Code Ver: Required: 1.22 Actual: 1.22
  DEMOD #1 Ver: 2b, Type: 0
  DEMOD #2 Ver: 2b, Type: 0
  PWRTIMG Ver: 2b, Type: 0

Board Serial Number Data:
  57 00 00 03 8F 26 DB 23 WHP727-2022-03A
  06 00 00 03 D4 C2 F9 23 PIO727-3023-13B
  07 00 00 08 D9 09 58 09 REC727-1000-03F

ISM Part Num: SNR71B-1048-61
ISM firmware version: 45.05
ISM serial number: 030000E3 23D7E86F
>
```

Verify the information is consistent with what you know about the configuration of your system. If **PS0** does *not* list all your sensors, there is a problem with either the communications to the transducer or a problem with the receiver board.

## Instrument Transformation Matrix

The script file will send the **PS3** command. This shows information about the transducer beams. The Workhorse II uses this information in its coordinate-transformation calculations; for example, the output may look like this:

```
ps3
Beam Width: 3.7 degrees

Beam      Elevation      Azimuth
  1        -70.14        269.72
  2        -70.10         89.72
  3        -69.99         0.28
  4        -70.01        180.28

Beam Directional Matrix (Down):
  0.3399  0.0017  0.9405  0.2414
 -0.3405 -0.0017  0.9403  0.2410
 -0.0017 -0.3424  0.9396 -0.2411
  0.0017  0.3420  0.9398 -0.2415

Instrument Transformation Matrix (Down):      Q14:
  1.4691 -1.4705  0.0078 -0.0067      24069 -24092  127 -109
 -0.0068  0.0078 -1.4618  1.4606      -111  127 -23950  23930
  0.2663  0.2657  0.2657  0.2661      4363  4354  4353  4359
```

```

1.0367 1.0350 -1.0359 -1.0374 16985 16957 -16972 -16996
Beam Angle Corrections Are Loaded.
>

```

If the Workhorse II has beam angle errors, they are reflected in the instrument transformation matrix and the Beam Directional matrix. This matrix, when multiplied by the raw beam data gives currents in the  $x$ ,  $y$ ,  $z$ , and  $e$  directions.

## Pre-deployment Test



The pre-deployment test requires you to immerse the transducer faces in water. If you do not, some of the tests may fail. Running the tests in air will not harm the ADCP.

The script file will send the **PA** diagnostic test. This checks the major Workhorse II modules and signal paths. For example, the output may look like this:

```

>PA
PRE-DEPLOYMENT TESTS
CPU TESTS:
  RTC.....PASS
  RAM.....PASS
  ROM.....PASS
RECORDER TESTS:
  PC Card #0.....DETECTED
  Card Detect.....PASS
  Communication.....PASS
  DOS Structure.....PASS
  Sector Test (short).....PASS
DSP TESTS:
  Timing RAM.....PASS
  Demod RAM.....PASS
  Demod REG.....PASS
  FIFOs.....PASS
SYSTEM TESTS:
  XILINX Interrupts... IRQ3 IRQ3 IRQ3 ...PASS
  Wide Bandwidth.....PASS
  Narrow Bandwidth.....PASS
  RSSI Filter.....PASS
  Transmit.....PASS
SENSOR TESTS:
  H/W Operation.....PASS

```

## Testing the Sensors

The script file will send the **PC2** test to display heading, pitch angle, roll angle, up/down orientation, and temperature in a repeating loop at approximately 0.5-sec update rate.

To test the sensors, rotate and tilt the system and verify the Pitch and Roll sensor data is reasonable. Rotate the system clockwise and verify the heading increases. Validate the accuracy at 0, 90, and 180 degrees. If the heading is off by more than 2 degrees, [calibrate the compass](#). If the pressure is not zero, zero the pressure sensor with the **AZ** command.

```

Press any key to quit sensor display ...
Heading  Pitch    Roll  Up/Down  Attitude Temp  Ambient Temp  Pressure
301.01°  -7.42°  -0.73°  Up       24.35°C      22.97°C      0.0 kPa
300.87°  -7.60°  -0.95°  Up       24.36°C      22.97°C      0.0 kPa
300.95°  -7.60°  -0.99°  Up       24.37°C      22.97°C      0.0 kPa
300.71°  -7.61°  -0.96°  Up       24.37°C      22.98°C      0.0 kPa

```

Sign of Angle for a Unit Facing	Up	Down
Pitch - Beam 3 higher than Beam 4	+	+
Roll - Beam 2 higher than Beam 1	+	-

Any key pressed exits this command and returns the user to the command prompt.

## Beam Continuity

The script file will send the **PC1** to test the beam continuity by measuring the quiescent Receiver Signal Strength Indicator (RSSI) levels. There must be a change of more than 30 counts when the transducer face is rubbed.

The **PC1** test is designed to measure the relative noise in the environment and then have you apply more noise by rubbing the ceramics with your hand. Sometimes your hand does not generate enough noise for the system to detect. This could be due to the environment you are in or for other reasons. A simple, safe, and easy to find material that works very well as a replacement to your hand is packaging material (a.k.a. bubble wrap). Using this instead of your hand will very likely provide enough relative frictional difference for the system to pass.

```
BEAM CONTINUITY TEST
When prompted to do so, vigorously rub the selected
beam's face.
If a beam does not PASS the test, send any character to
the ADCP to automatically select the next beam.
```

```
Collecting Statistical Data...
 52 48 50 43
```

```
Rub Beam 1 = PASS
Rub Beam 2 = PASS
Rub Beam 3 = PASS
Rub Beam 4 = PASS
```



This test must be performed with the ADCP out of water and preferably dry.

If the **PC1** test fails, your system may still be okay. In this case deploy the ADCP into a bucket or container of water (preferably at least 0.5 meters deep). Record some data using *TRDI Toolz* and the log file (**F3** key), or record data straight to the recorder card if your ADCP has one. Then look at the data using the *WinADCP* program and make sure that the echo amplitude counts in the 1st depth cell for all beams is between 128 and 192. If they are not, contact Field Service for further troubleshooting tips.



# Dock Side Tests

The following checks should occur at Dock Side prior to performing the Sea Acceptance Tests. These tests will verify the WorkHorse ADCP is ready for the Sea Acceptance Tests and confirm the peripherals attached to the ADCP.



These tests only apply to moving vessel deployments.

## Dock Side Diagnostic Test

The following test will confirm the connection of the WorkHorse Deckbox (Mariner) to the Transducer or WorkHorse to the computer.

**Table 8: Dock Side Test Set Up**

Set up	Description
Platform/Vessel	The vessel should be tied to the dock or at anchor. The transducer should be in water. All other sonar devices and equipment should be turned off.
WorkHorse	Connect the ADCP as described in <a href="#">Setting up the WorkHorse System</a> . The Navigation connection may or may not be connected at this point.
Computer	The <i>TRDI Toolz</i> program should be running, communications port setting (F5) to match the connection to the PC and WorkHorse ADCP baud rate requirements (default 9600,N,8,1).

Use the following steps to interconnect the WorkHorse system and to place the ADCP in a known state.

1. Interconnect and apply power to the system as described in [Setting up the WorkHorse System](#).
2. Start the *TRDI Toolz* program.
3. Press **End** to wake up the ADCP. Send the PA command to the ADCP. See [Pre-deployment Test](#) for an example of the test result printout.

## Dock Side Peripheral Tests

The WorkHorse requires (at minimum) input for heading (true north) and for position fixes (GPS). Additionally, the WorkHorse can make use of pitch and roll data to correct for the tilt.

Heading can be input and combined with WorkHorse data in the computer software *VmDas*. This heading input is done through the communications port of the computer with the NMEA 0183 string \$HDT or \$HDG as specified in the **Transforms** tab in *VmDas*.

Pitch and Roll data can be input and combined with WorkHorse data in the computer software *VmDas*. This heading input is done through the communications port of the computer with the TRDI proprietary NMEA string \$PRDID.

Navigation data can only be combined with WorkHorse data in the computer software *VmDas*. This navigation input is done through the communications port of the computer with the NMEA proprietary strings \$GGA and \$VTG.



See the *VmDas* User's Guide and/or the WinRiver II User's Guide for help on integrating NMEA Devices.

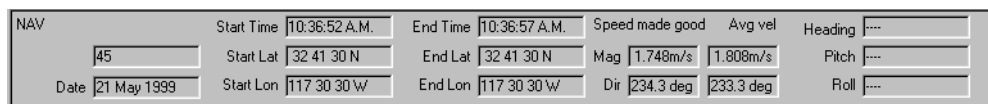
**Table 9: Dock Side Peripheral Tests Set up**

Set up	Description
Platform/Vessel	The Navigation, and Pitch/Roll sensors should be attached to the appropriate place on either the WorkHorse Deckbox or the computer communication port. The devices should be on and should stable.
WorkHorse	The WorkHorse should be connected as described in <a href="#">Setting up the WorkHorse System</a> , AC Power connected to the Deckbox/ADCP, and the power switch turned on.
Computer	The <i>TRDI Toolz</i> program should be running, communications port setting (F5) to match the connection to the PC and WorkHorse ADCP baud rate requirements (default 9600,N,8,1).

**Testing the Navigation Connections to the Compute (VmDas)r**

Start *VmDas* in the Data Collect mode. On the **View** menu, select **NMEA Communications**. Confirm that the Navigation Device NMEA string is viewable and the \$GGA string is present.

The **Navigation Data** window in *VmDas* (see Figure 75) shows a text box of the position and velocity data from a NMEA navigation device. You can use this to verify the navigation connections.



**Figure 75. Testing the Navigation Connections**

**Testing \$HDG Heading Connections to the Computer (VmDas)**

Start *VmDas* in the Data Collect mode. On the **View** menu, select **Nmea Communications**. Confirm that the Navigation Device NMEA string is viewable and the \$HDG string is present. Note that the data for this information may appear on the same communications port as the navigation data or on a separate input port.

**Testing \$PRDID Heading Connections to the Computer (VmDas)**

Start *VmDas* in the Data Collect mode. On the **View** menu, select **Nmea Communications**. Confirm that the Navigation Device NMEA string is viewable and the \$PRDID string is present. Note that the data for this information may appear on the same communications port as the navigation data or on a separate input port.

**Testing the Navigation Connections to the Compute (WinRiver II)r**

Start *WinRiver II* in the Acquire mode. On the **View** menu, select **Device Logs**. Confirm that the Navigation Device NMEA string is viewable and the \$GGA string is present.

**Table 10: Dock Side Peripheral Test Results**

Test	Test Criterion
External Heading NMEA Connection Test	Verify that the Navigation Device NMEA string is viewable and the \$GGA string is present.
External Heading NMEA Connection Test	Verify that the Navigation Device NMEA string is viewable and the \$HDT or \$HDG string is present.
External Heading NMEA Connection Test	Confirm that the Navigation Device NMEA string is viewable and the \$PRDID string is present.

# Sea Acceptance Tests

This procedure is intended to test the WorkHorse at sea. This procedure assumes that the Dock Side Testing (see [Dock Side Tests](#)) procedure has been run and that all of the items have passed or been confirmed to be operational. The following tests will not obtain favorable results unless all of this work has been performed.



These tests only apply to blue water moving vessel deployments using *VmDas*. See the *VmDas* User's Guide for instructions on how to use this program.

The reason for Sea Acceptance Testing is that although the Dock Side Tests confirm the WorkHorse is operational, they do not confirm that the system is able to perform to its specifications. The performance of any ADCP relies greatly upon the installation into any platform. Therefore, the system must be tested at sea to understand the effects of the platform on the ADCP performance.

At Sea Testing includes tests for Acoustic Interference, Profiling Range, and Profiling Reasonableness testing. For each of these tests, the following equipment and ADCP set up requirements are recommended.

## **Equipment Required**

- WorkHorse 300 kHz, 600 kHz, or 1200 kHz ADCP with firmware 16.xx or greater
- Computer
- *VmDas* Program
- *WinADCP* Program
- Navigation Interface Connected
- Heading Interface Connected

## **VmDas Set up**

1. Start *VmDas*. On the **File** menu, click **Collect Data**. On the **Options** menu, click **Load**. Select the Default.ini file and click **Open**.
2. On the **Options** menu, click **Edit Data Options**. Click the **ADCP Setup** tab. Set the **Ensemble Time** to the **Ping as fast as possible**.
3. Select the **Use Command File** box. Use Table 11 to choose a command file for your ADCP, and load it into *VmDas* using the **Browse** button.

**Table 11: Command Files**

File Name	Description
WH300DEF.txt	Default set up for a WH 300 kHz ADCP to provide the most range with the optimal precision.
WH600DEF.txt	Default set up for a WH 600 kHz ADCP to provide the most range with the optimal precision.
WH1200DEF.txt	Default set up for a WH 1200 kHz ADCP to provide the most range with the optimal precision.

4. On the **Options** menu, click **Edit Data Options**. Click the **Averaging** tab. Set the **Short Term Average** to 300 seconds (5 minutes). Set the **Long Term Average** to 600 seconds (10 minutes).

## Interference Test

The WorkHorse transmits and receives acoustic signals from the water. If other sonar devices are operating on the platform at the same time as the ADCP it is possible for those signals to bias the ADCP data. Therefore, all ADCPs must be tested to ensure that they are not receiving interference from other sonar equipment on board the vessel.

The following Interference Test will determine if there is interference from other devices on board the vessel.

### Interference Test Platform Test Set up

This test requires that the platform be in water deeper than the ADCP’s maximum expected profiling range. Use the following table to determine the minimum water depth required.

**Table 12: Interference Test Minimum Water Depth Requirement**

300 kHz ADCP	600 kHz ADCP	1200 kHz ADCP
400 meters	150 meters	60 meters

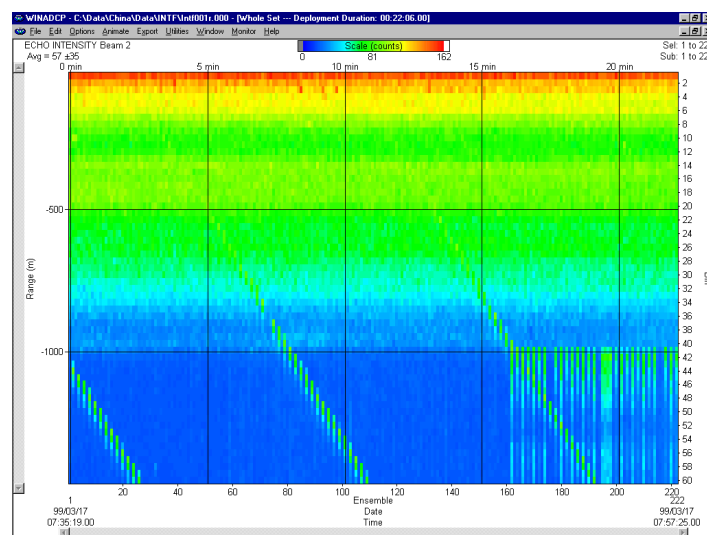
The platform speed for this test is drifting. The motors may be running if required for platform safety. The test sequence starts with ALL sonar and non-essential electronic equipment turned off. Only the ADCP should be on for the first test. This test establishes a base line for the interference and is critical to the rest of the tests. After a 10-minute period the first sonar device is turned on, transmission started, and the data is reviewed for interference terms. At the end of this 10-minute period the first sonar device is turned off and then the next sonar device is turned on and started pinging for 10 minutes. This process repeats for each of the sonar devices.

### Interference Test Computer Screen Display Set up

View the RAW data (\*.ENR files) being collected by the *VmDas* program in the *WinADCP* program contour plots for echo intensity data. This data will show the single ping return levels.

### How to Identify Interference

If there is an interference term, the echo intensity data will show spurious echo intensity jobs. An example of what an interference term may look like what is shown in Figure 76.



**Figure 76. Interference Test**

The interference term appears as the periodic green blocks in the data set. The interference is somewhat lost in the upper part of the profile however it can be clearly seen once the system reaches the noise floor (the point where signals are no longer being returned from the water).



Interference terms such as above seen anywhere in the echo intensity profile data will result in a bias to the ADCP data.

## Water Profile Range Test

The range of any ADCP is directly dependent on the level of backscattering material in the water, the transmit power into the water, the received sensitivity, and the level of the background noise. Each of these effects the range of the system in different ways, but in the end can result in reduced or extended range as follows.

- The ADCPs transmit power and receive sensitivity are fixed based on the transducer frequency. However, these may be affected by installation of an acoustic window in front of the transducer. A window will absorb both sound transmitted by the ADCP and the sound returned from backscatter in the water.
- The volume of the backscatter in the water will affect the range. All specifications for range assume that there is a certain amount of backscatter in the water. The backscatter volume is not controllable in any way.
- The background noise changes as the platform's speed increases or decreases. There are two types of noise created by the moving platform; first, there is the noise due to propeller and engines; and second, there is the noise created by the rushing water across the platform and ADCP transducer.

This test is used to determine the effects of the background noise on the range of the ADCP. This information can be used to determine the optimum speed of the platform to obtain the desired range required.

### Water Profile Range Platform Test Set up

This test requires that the platform be in water deeper than the ADCP's maximum expected profiling range. Use the following table to determine the minimum water depth required.

**Table 13: Water Profile Range Test Minimum Water Depth**

300 kHz	600 kHz	1200 kHz
250 meters	100 meters	40 meters

The platform course for this test is a continuous straight line. The speed of the platform will be varied during this test. At each speed, the system will be set to collect data for a minimum of 10 minutes. The following table lists the recommended speeds.

**Table 14: Water Profile Range Test Platform Speed**

Test #	Speed
Speed 1	Drifting
Speed 2	3 knots
Speed 3	6 knots
Speed 4	9 knots
Speed 5	12 knots
Speed 6	Maximum Speed

## Water Profile Range Computer Screen Display Set up

View the Tabular Display of the Long Term Average data (10 minute averages) in the *VmDas* program.

### How to Determine the Maximum Range of the ADCP

The data collected in the long-term average (10 minutes) tabular display will be used to determine the maximum range of the ADCP. The maximum profiling range of the system is determined by locating the last valid bin and then using that ping to determine the range. To determine the last valid bin the following criterion is used:

- The last bin must be above the bottom side lobe area
- The bin must be > 25% of the sum of 3-beams Solutions (percent good 1) and 4-beams Solutions (percent good 4), [(PG1 + PG4) > 25%].
- The correlation value for at least 3 beams must be above the threshold of 64 counts

Locate the last valid bin for each of the speeds and fill in the table below.

Platform Speed	Last Valid Bin Number	Range to Last Bin	Average RSSI Value at Last Bin
----------------	-----------------------	-------------------	--------------------------------

#### Notes:

- Platform Speed must be input as a measurement from the Bottom Track (if in range) or the GPS speed.
- Range to Last Bin is calculated as follows: ((bin size) \* (last bin number)) + (NF command)
- Average RSSI Value at Last Bin is the average of the 4 beams RSSI values in the last bin number

The results from the above test should be compared to the specified nominal range of the system. Assuming that there are sufficient scatterers in the water, the acoustic window is not attenuating the signal, and that that the platform background noise is variable there should be a speed at which the nominal range of the system is obtained.

## Ringling Test

The ADCP transmits an acoustic pulse into the water. The main lobe of this pulse bounces off particles in the water and the signals returned from these particles are used to calculate the velocity of the water. The main lobe of the transmitted pulse is what we are using to process and calculate a velocity. The transmitted pulse, however, is made up of many side lobes off the main lobe. These side lobes will come in contact with metal of the transducer beam itself and other items in the water.

The energy from the side lobes will excite the metal of the transducer and anything bolted to the transducer. This causes the transducer and anything attached to it to resonate at the system's transmit frequency. We refer to this as "ringing." If the ADCP is in its receive mode while the transducer is ringing then it will receive both the return signals from the water and the "ringing." Both of these signals are then processed by the ADCP. The ringing causes bias to the velocity data.

All ADCPs “ring” for some amount of time. Therefore, each ADCP requires a blanking period (time of no data processing) to keep from processing the ringing energy. Each ADCP frequency has a different typical ringing duration. A blanking period (time of not processing data) is required at the beginning of each profile. The blanking distances recommended for the typical ringing period for each WorkHorse frequency is shown in the following table.

**Table 15: Recommended Blanking Distance**

Frequency (kHz)	200m Rated	500m Rated	1000m Rated	1500m Rated	3000m Rated	6000m Rated
1200	0.05 to 0.51m	0.05 to 0.51m	0.05 to 1.05m	n/a	n/a	0.05 to 1.05m
600	0.1 to 1.02m	0.1 to 1.02m	0.1 to 2.1m	n/a	n/a	0.1 to 2.1m
300	0.2 to 2.04m	0.2 to 2.04m	0.2 to 3.54m	n/a	n/a	0.2 to 3.54m
150	n/a	n/a	n/a	4.0m	4.00m	4.00m
75	n/a	n/a	n/a	8.0m	8.00m	n/a

Ringing will bias the velocity estimation to a lower value than it should be. However, when the platform motion is removed from the water profile data it will appear as a large velocity, which is the opposite of what it is really doing. This effect is caused because the vessel motion portion of the water profile data has been biased low.

## Ring Test Platform Test Set up

The key to success on this test is that the water velocity and direction not change over the entire test period of 120 minutes. This may be difficult to adhere to in regions with large tidal effects. The test requires that the platform be within the ADCP bottom tracking range so that valid bottom track can be used. Use the following table to determine the optimum water depth range required.

**Table 16: Ringing Test Water Depth Requirement**

300kHz ADCP	600kHz ADCP	1200kHz ADCP
100-200 meters	50-100 meters	10-20 meters

Platform speed should be held to as fast a speed as possible without losing any bottom tracking data for a period of 30 minutes. Typically, this will be a speed of 6-9 knots. Some experimentation may be required to find the maximum bottom track speed for the given depths above.

## Ring Test Computer Screen Display Set up

The Magnitude and Direction Profile Display of the Long Term Average data (10 minute averages) will be viewed in the *VmDas* program.

## How to Determine the Ringing Test Results

Viewing the Long Term average of the magnitude and direction profile data, look for unreasonable shears from bin 1 to bin 2 to bin 3 and so on. If an unreasonable shear is seen, this is most likely ringing and your blanking needs to be increased by the following formula:

$$(\text{bin size}) * (\text{last bin number with ringing}) * 0.80$$

\*The total blanking period is typical blanking period plus the increased blanking period required. The above value should be used to change both the NF and WF commands in all configuration files for this ADCP.



# Transducer Alignment Test



This test only applies to WorkHorse Mariner systems using an external heading.

The mounting alignment of the transducer to the relative position of the heading input from the vessel is critical in the velocity estimates made by the ADCP. If either of these are not known and corrected for, it will result in both directional and velocity estimate errors in the velocity data.

It is possible to confirm if the transducer alignment is correct by collecting data over the same water in several different directions. If the transducer is aligned, then the both the magnitude and direction of the currents will appear the same in all directions that the platform travels.

## Platform Testing Setup

The key to success on this test is that minimal water velocity and direction change over the entire test period. The following test will take a minimum of five hours to collect. This length of time is required in order to obtain enough data samples to reduce the noise sufficiently. This test requires that the platform be within the ADCP bottom tracking range, so that valid bottom track can be used, and that reliable GPS data be available (DGPS is recommended). Use the following table to determine the optimum water depth range required.

**Table 17: Transducer Alignment Test Water Depth Requirement**

Mariner 300 kHz	Mariner 600 kHz
80-160 meters	25-75 meters

The platform speed is to be held at a constant speed. Any speed between 5 to 10 knots is acceptable, however once a speed is selected then the vessel should maintain that speed during the entire course. The course for this test contains a minimum of five legs. Each leg must be a minimum of 30 minutes long (1 to 2 hours per leg is the optimal time). The course of ship travel is shown in Figure 77. All data must be collected in beam coordinates.

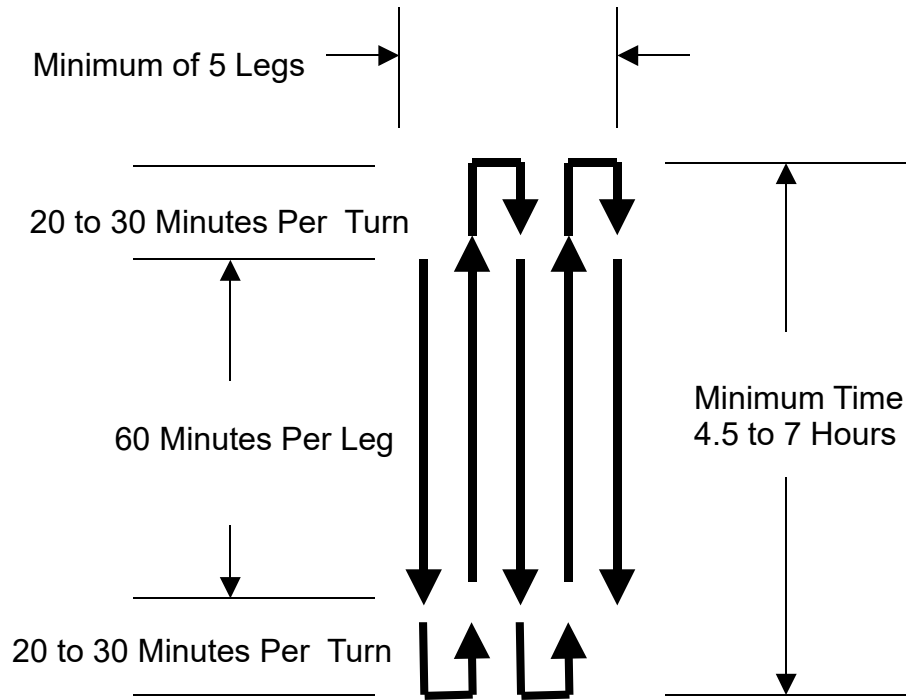


Figure 77. Transducer Alignment Test

### Computer Screen Display Setup

View the *VmDas* ship track display of bin 3 with the bottom track reference. The Long Term Average (5 minute averages) data should be viewed.

Each of the vertical lines represents the point when the vessel changed directions.

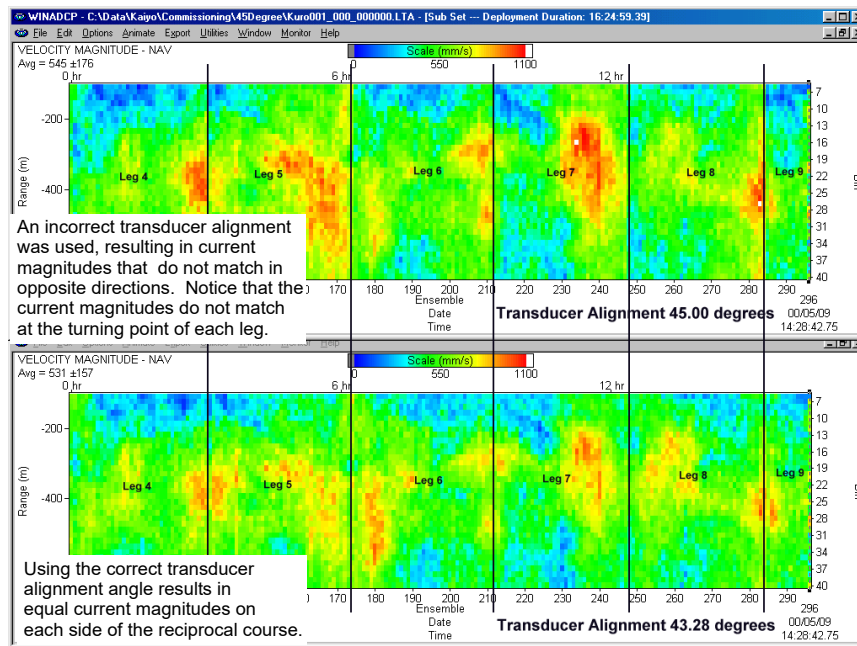


Figure 78. Transducer Alignment Display

## Transducer Alignment Results Sheet

A pass condition is if the velocities in each of the ship track plotted directions has the reasonably the same magnitude and direction. It is common to see some wild velocity magnitude and directions. This happens as a result of the effects of the latency of the heading updates for a GPS heading input.

If the direction of the currents is not the same in each of the directions then it will be necessary to enter in a transducer misalignment angle. The 5-minute averages of both GPS and Bottom Track Direction are compared in at least 2 of the legs traveled. An average direction along each leg is calculated for both the GPS and Bottom Track data. The difference in the average directions is the misalignment angle.

Record the results of this portion of the Transducer Alignment with Bottom Track Reference with the formula:

Misalignment Angle = (GPS Average Direction) – (Bottom Track Average Direction)

Misalignment Angle Required	Degrees
-----------------------------	---------

Changing the transducer alignment angle, reprocessing the data, and finally playing back the same data file again allows you to confirm if the misalignment angle correction is correct. A pass condition is if the velocities in each of the ship track plotted directions has the reasonably the same magnitude and direction. It is common to see some wild velocity magnitude and directions.

Record the results of the verification of the Transducer Alignment with Bottom Track Reference:

Alignment Verification	Pass/Fail
------------------------	-----------

Change the data display reference from bottom track to the navigation data in the VMDAS program. A pass condition exists if little to no change in the velocity magnitude and direction occurred when switching to the navigation data reference

Record the results of this portion of the Transducer Alignment with Navigation Reference:

Navigation Verification	Pass/Fail
-------------------------	-----------

## Water Profile Reasonableness Test

The mounting alignment of the WorkHorse transducer to the relative position of the heading input from the vessel is critical in the velocity estimates made by the ADCP. If either of these are not known and corrected for, it will result in both directional and velocity estimate errors in the water velocity data.

It is possible to confirm if the transducer alignment is correct by collecting data over the same water in several different directions. If the transducer is properly aligned, then both the magnitude and direction of the currents will appear the same in all directions that the platform travels.

### Water Profile Reasonableness Platform Test Set up

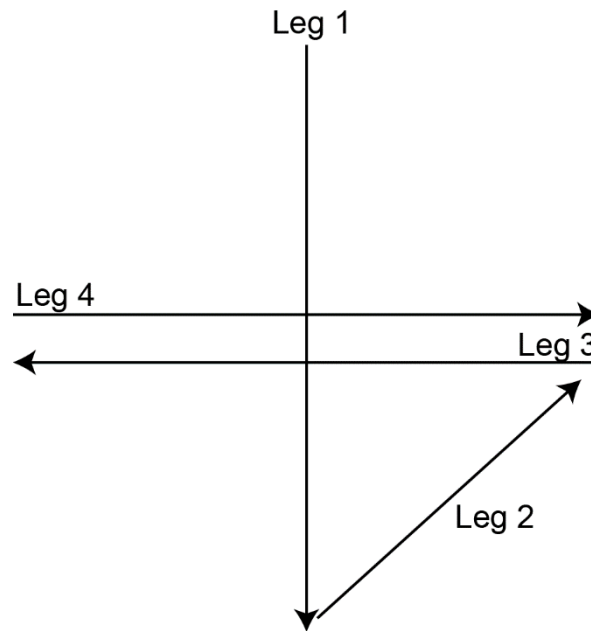
The key to success on this test is that the water velocity and direction not change over the entire test period of 120 minutes. This may be difficult to adhere to in regions with large tidal effects. The test requires that the platform be within the ADCP bottom tracking range so that valid bottom track can be used. Use the following table to determine the optimum water depth range required.

**Table 18: Water Profile Reasonableness Water Depth Requirement**

300 kHz	600 kHz	1200 kHz
100-200 meters	50-90 meters	10-40 meters

Platform speed is held at a constant 5 knots during the entire course. The course for this test contains 4 legs. Each leg must be approximately 4500 meters (except for leg 2 which will be one half the length of

each of the other legs). The course will appear as shown in Figure 79. The actual starting direction is not critical as long as the course completes the pattern shown in Figure 79.



**Figure 79. Water Profile Reasonableness Course**

## Water Profile Reasonableness Display Set up

View the *VmDas* Ship Track display of bin 3 with the bottom track reference. The Short Term Average (5 minute averages) data should be viewed.

## How to Determine Water Profile Reasonableness

A pass condition is if the velocities in each of the ship track plotted directions has reasonably the same magnitude and direction. It is common to see some wild velocity magnitude and directions during turns. This happens as a result of the effects of the turn the latency of the heading updates for a GPS heading input.

If the direction of the currents is not the same in each of the four directions, then it will be necessary to enter in a transducer misalignment angle. Changing the transducer alignment angle and playing back the same data file again allows you to determine the misalignment angle. The best way to perform this check out is to use incremental change of 5-10 degrees at a time.

Assuming that the misalignment angle was not required or could be determined, it is now possible to use the same data just collected to determine how reasonable the navigation data input is. Change the data display reference from bottom track to the navigation data in the *VmDas* program. There should be little to no change in the velocity magnitude and direction if the navigation data is a valid input for a reference.

## Bottom Tracking Test

The bottom tracking capability of the ADCP varies depending on the type of bottom (hard, soft, rock, sand, etc.), the slope of the bottom, and the speed of the vessel (background noise).

Before testing the Bottom Track capabilities, the Water Profiling Range Test must be performed. Through the results of this test, determine the platform speed in which the range to the last valid bin obtained the specified nominal range of the ADCP frequency being used.

If it was not possible to reach the specified nominal range during the Water Profiling Range test, then determine the speed at which it allowed the best range possible. Calculate the percentage of the nominal range that was obtained by the system.

## Bottom Tracking Platform Test Set up

The key to this test is to operate the system in an area where both the minimum and maximum bottom tracking range can be obtained. The platform will travel over water that is very shallow (<10 meters) to very deep (greater than the maximum bottom track range). It does not matter if the water starts deep and goes shallow or vice-versa.

The course of the platform should be a relatively straight line. The platform speed should be no greater than the velocity recorded in the Water Profiling Range Test.

## Bottom Tracking Computer Screen Display Set up

View the raw data display of the *VmDas* bottom track display window.

## How to Determine Bottom Tracking Reasonableness

Viewing the bottom track velocity data, record the maximum and minimum average of the bottom track depths in the table below.

Beam Number	Minimum Depth (meters)	Maximum Depth (meters)
Beam 1		
Beam 2		
Beam 3		
Beam 4		

A pass condition is if the maximum depth of the system is equal to the specification for the nominal bottom track range.



If the system was not able to water profile to the nominal range, then the bottom track range should be reduced to no more than the same percentage as the water profile loss.

If the Bottom Track did obtain the complete range and the Water Profile did not, then it is likely that there is insufficient backscatter in the water to obtain the specified range.

NOTES

# Chapter 6

## TROUBLESHOOTING



In this chapter, you will learn:

- Basic Steps in Troubleshooting
- Troubleshooting a Communication Failure
- Troubleshooting a Built-In Test Failure
- Troubleshooting a Beam Failure
- Troubleshooting a Sensor Failure
- System Overview



Considering the complexity of the WorkHorse, TRDI has provided as much information as practical for field repair; *fault location to the component level is beyond the scope of these instructions*. The provided information assumes that faults are isolated with a large degree of certainty to a Least Replaceable Assembly (LRA) level only. The time to repair the system will be minimized if an entire replacement unit is available in the field. If time to repair is of essence, Teledyne RD Instruments strongly advises the availability of the listed LRAs.

**Table 19: List of Least Replaceable Assemblies**

LRA	Description
ADCP	The entire ADCP; includes the electronics, housing, transducer ceramic assemblies, and end-cap.
Deckbox (Mariner only)	The Deckbox contains all electronics necessary to supply power, provide user communication.
I/O Cable	Connects the ADCP with the Deckbox (Mariner) or Computer.
Serial Cable	Connects the Mariner Deckbox to the computer.
End-Cap	Includes the end-cap, connector, and internal I/O cable.
ADCP electronics	The spare boards kit Includes the PIO and WHP boards.
PC/CF Card	Replaceable PC/CF recorder card.

Since these Least Replaceable Assemblies are manufactured in different configurations, please contact Teledyne RD Instruments Field Service to obtain the correct part number for your specific system configuration. When contacting Teledyne RD Instruments about a replacement assembly, please provide the serial numbers of the ADCP and Deckbox. If you want to replace the I/O Cable only, then please provide the cable length.

## Equipment Required

Special test equipment is not needed for trouble shooting and fault isolation. The required equipment is listed in Table 20. Any equipment satisfying the critical specification listed may be used.

**Table 20: Required Test Equipment**

Required Test Equipment	Critical Specification
DMM	Resolution: 3 ½ digit DC-Voltage Range: 200 mV, 2V, 20 V, 200V DC-Voltage Accuracy: ± 1% AC-Voltage Range: 200 V, 450 V AC-Voltage Accuracy: ± 2% Resistance Range: 200, 2 k, 20 k, 200 k, 20 MOhm Res.-Accuracy: ± 2% @ 200 Ohm to 200 kOhm Res.-Accuracy: ± 5% @ 20 MOhm Capacitance Range: 20 nF, 2 uF, 20 uF Capacitance Accuracy: ± 5%
Serial Data EIA Break-Out Box such as from International Data Sciences, Inc. 475 Jefferson Boulevard Warwick, RI 02886-1317 USA.	Model 60 or similar is recommended as it eases the troubleshooting of RS-232 communication problems significantly. Other manufacturers or models may be substituted.



The EIA Break-out Panel is not necessary, but eases RS-232 communication problems troubleshooting significantly.

# Basic Steps in Troubleshooting

The first step in troubleshooting is determining what type of failure is occurring. There are four types of failures:

- Communication failure
- Built-In test failure
- Beam failure
- Sensor failure

**Communication failures** can be the hardest problem to solve as the problem can be in any part of the system (i.e. the computer, WorkHorse, cable, or power). The symptoms include having the system not respond, or not responding in a recognizable manner (for example “garbled” text).

**Built-In test failures** will appear when the system diagnostics are run. Use *TRDI Toolz* to identify the failing test.

**Beam failures** can be identified when collecting data or during the user-interactive performance tests.

**Sensor failures** can also be identified when collecting data or during the user-interactive performance tests. The sensor may send incorrect data, or not be identified by the system.

## Troubleshooting the WorkHorse

Although the WorkHorse is designed for maximum reliability, it is possible for a fault to occur. This section explains how to troubleshoot and fault isolate problems to the Least Replaceable Assembly level (see Table 19). Before troubleshooting, review the procedures, figures, and tables in this guide. Also, read the [System Overview](#) to understand how the WorkHorse processes data.



Under all circumstances, follow the safety rules listed in the Troubleshooting Safety.

## Troubleshooting Safety

Follow all safety rules while troubleshooting:



Servicing instructions are for use by service-trained personnel. To avoid dangerous electric shock, do not perform any service unless qualified to do so.



Complete the ground path. The power cord and the outlet used must have functional grounds. Before power is supplied to the WorkHorse, the protective earth terminal of the instrument must be connected to the protective conductor of the power cord. The power plug must only be inserted in a socket outlet provided with a protective earth contact. The protective action must not be negated by the use of an extension cord (power cable) without a protective conductor (grounding). Grounding one conductor of a two-conductor outlet is not sufficient protection.



Any interruption of the earthing (grounding) conductor, inside or outside the instrument, or disconnecting the protective earth terminal will cause a potential shock hazard that could result in personal injury.



Only fuses with the required rated current, voltage, and specified type must be used. Do not repair fuses or short circuit fuse-holders. To do so could cause a shock or fire hazard.



Do not install substitute parts or perform any unauthorized modifications to the instrument.



Measurements described in the manual are performed with power supplied to the instrument while protective covers are removed. Energy available at many points may, if contacted, result in personal injury.



Do not attempt to open or service the power supply.



Any maintenance and repair of the opened instrument under voltage should be avoided as much as possible, and when inevitable, should be carried out only by a skilled person who is aware of the hazard involved.



Capacitors inside the instrument may still be charged even if the instrument has been disconnected from its source of supply.

## Troubleshooting a Communication Failure

WorkHorse ADCPs communicate by means of two serial communication channels. The user can choose between RS-232 and RS-422 classes of serial interfaces with a switch on the PIO board in the ADCP.

To successfully communicate, both the host computer and the ADCP must communicate using the same class of serial interface. Standard serial interfaces in IBM compatible computers are also RS-232.



If you have just received your WorkHorse from TRDI, the standard configuration is RS-232 for Sentinels and RS-422 for Monitors and Mariners.



If you are using a high baud rate and/or a long I/O cable (greater than 50 meters) connected to a Sentinel ADCP, RS-232 may not work. Switch to RS-422 and try to wake up the WorkHorse again.



Most communication problems are associated with incorrect cabling (i.e. the serial cable is connected to the wrong port) or data protocols (i.e. the wrong baud rate is set between the ADCP and computer).

### Incorrect Wakeup Message

When you send a break and the wakeup message is not readable (garbled), this may indicate a communications mismatch or lost boot code.

- Sending a break causes “garbage” to appear on the screen. The “garbage” text may keep scrolling. This happens when the computer is using RS-232 and the ADCP is set for RS-422 or vice-versa. Check the RS-232/RS-422 switch on the PIO board (see [Communications Setting](#)).
- Sending a break causes “garbage” to appear on the screen. You can hear the ADCP “beep” when the break is sent. The “garbage” text does not keep scrolling. Check that the ADCP and computer are both using the same baud rate.

If you are unsure of the ADCP's baud rate, use **Tools, Find ADCP**. *TRDI Toolz* will try different baud rates until it connects to the ADCP.

```
>{ ;7φ²∩∥∥²²jñ~ªñδgJ Checking 9600 baud rate
Checking 115200 baud rate
```

```
==
```

```
Workhorse II Broadband ADCP Version 77.xx
Teledyne RD Instruments (c) 1996-2021
All Rights Reserved.
```

```
>
```

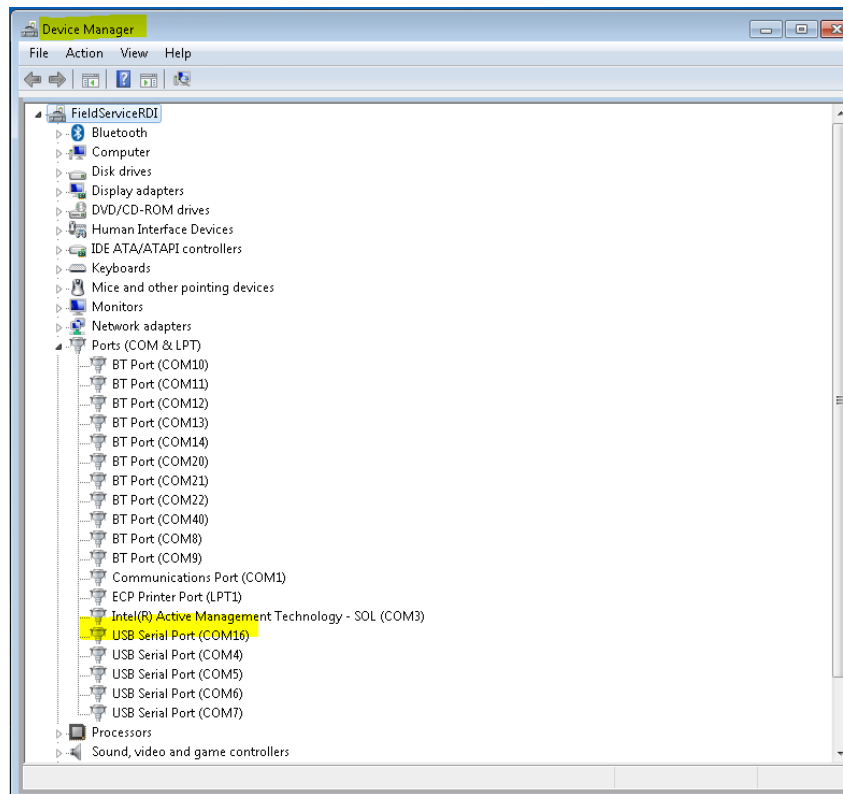
- If the ADCP gives a steady “beep” when power is applied, the “>” prompt appears on the screen, and an “X” appears when additional breaks are sent, this may indicate that the boot code has been lost. This can happen if you abort while downloading new firmware. Try downloading the firmware again.
- If you have problems communicating with the system, check to make sure that you are selecting the right COM port, baud rate, parity (none), stop bits (1), flow control (none).

Windows is finicky when it comes to USB to serial adapters. The included USB adapter is P/N ES-U-1001-R10 USB to RS232 adapter with FT232R chipset from [Connective Peripherals - US Store](#). Possibly any device with FTDI drivers and devices will also work.

#### Installing the USB to Serial Adapter Driver

If there is an available internet connection, Windows 10/11 will silently connect to the Windows Update service and install the USB driver on first connection. If needed, install the USB to Serial adapter Virtual COM Port (VCP) driver available on: <https://ftdichip.com/drivers/>

- If you don't know what com ports were added when using a USB to serial adapter, use *Windows Device Manager*® to determine the Com port as shown in the snapshot for a Windows 7® laptop.



If you have many ports as shown above and are not sure of which port is the USB to serial adapter one, remove the adapter, wait a moment, note the list of ports, reinsert the adapter and note the new port. In the example above, Com 16.

- If the system is set for RS-422, then check to make sure the host computer supports RS-422 or use an RS-422/RS-232 converter. TRDI recommends the B&B Electronics (<http://www.bb-elec.com/>) RS-422/RS-232 converter.



## No Wakeup Message

When you send a Break and do not see the wakeup message, you need to isolate the problem to a computer fault, power, cable failure, or an ADCP problem.

Check the following items:

1. Connect the ADCP to a computer as shown in [Setting up the WorkHorse System](#). Check that all cable connections are tight.

2. Is the ADCP AC power adapter working? Is the input voltage to the AC power adapter between 100 to 240 VAC? Is the output level 48 VDC?
3. If the ADCP is running from a battery, check that the battery voltage is above 30 VDC. ADCPs will work at 20 VDC with at least 400 milli amps; however, both lithium and alkaline battery packs with voltages below 30 VDC are at or near their end of life, and are approaching uselessness.
4. Is the computer hooked up properly? Does it have power?
5. Make sure that your computer and the *TRDI Toolz* programs are set up to use the communication port the serial cable is connected to on the computer.
6. In the case where the ADCP is only able to accept a SOFT BREAK due to telemetry components that will not “pass” a HARD BREAK to the ADCP and where you can cycle power, TRDI recommends that you consider removing power for one week. Re-apply power after a week and the ADCP should wake up.



The ADCP automatically stores the last set of commands used in RAM. Removing power for one week allows the RAM to lose its backup power. When power is re-applied, the ADCP will then do a ‘cold start’ (see [ADCP Checks](#)).

This is something that can be done without recovering the instrument. It assumes power can be cycled without recovering the ADCP and the ADCP is still functioning. The cost benefits of waiting a week needs to be weighed against the cost of divers recovering the ADCP.

## Check the Power

The following test can be done with a voltmeter to check the power. Check the power going into the ADCP by measuring the voltage on the end of the cable that connects to the WorkHorse at Pins 3 and 7 (GND) (see [WorkHorse Cables](#)). The voltage should be +48 VDC (using the standard AC adapter) or +48 VDC if you are using the Deckbox. If not, check the voltage at the other end of the cable, the AC adapter, and Deckbox (Mariner only).

## Check the I/O Cable

This test will check the communication between the computer and Monitor or Sentinel WorkHorse.

To check the cable:

1. Disconnect both ends of the cable and measure the continuity using a DMM (see [WorkHorse Cables](#) for the wiring diagram). Correct any problems found.
2. Reconnect the I/O cable to host computer.
3. Load *TRDI Toolz* on your computer. Select the proper communications port (see the *TRDI Toolz* help file).
4. For RS-232 communications, short pins 1 and 2 together on the female 7-pin connector that was plugged into the WorkHorse (see [WorkHorse Cables](#)). If you are using RS-422, connect a jumper between pin 2 to pin 6 and another jumper between pins 1 to pin 5 of the underwater connector at the WorkHorse end of the cable.
5. Type any characters on the keyboard. The keys you type should be echoed on the screen. If you see characters, but not correctly (garbage), the cable may be too long for the baud rate. Try a lower baud rate. If this works disconnect the jumper on pins 1 and 2 and then push any keys on the keyboard. You should NOT see anything you type.
6. If the keys are echoed correctly on the screen, the computer and the communication cable are good. Re-connect the I/O cable to the WorkHorse. The above loop-back test does not show if

transmit and receive pairs are interchanged. Thus, it is important that you check the wiring diagrams provided in [WorkHorse Cables](#).



A loop-back test does not show if transmit and receive wires or pairs are interchanged, even though characters may be displayed correctly.

## Check the Mariner Cables

This test will check the serial communication cable between the computer and Deckbox (Mariner only).

To check the cable:

1. Disconnect both ends of the cable and measure the continuity using a DMM (see [WorkHorse Cables](#) for the wiring diagram). Correct any problems found.
2. Reconnect the serial cable to host computer. Start the Teledyne RD Instruments software utility program *TRDI Toolz* on your computer. Make sure to select the proper communications port.
3. For testing a RS-232 cable, jumper pins 2 and 3 at the far end of the cable. To check a RS-422 cable, connect one jumper between pin 2 to 4, and one jumper between pins 7 to 8.
4. Type any characters on the keyboard. The keys you type should be echoed on the screen. If you see some characters, but not correctly, the cable may be too long for the baud rate. Try a lower baud rate. If this works disconnect the jumper and then push any keys on the keyboard. You should NOT see anything you type.
5. If you use cables that are **not** supplied by Teledyne RD Instruments you must make sure that transmit and receive pairs are not interchanged. The above loop-back test does not show if transmit and receive pairs are interchanged. Thus, it is important that you check the wiring diagrams provided in [WorkHorse Cables](#).



A loop-back test does not show if transmit and receive wires or pairs are interchanged, even though characters may be displayed correctly.

6. If the keys are echoed correctly on the screen, the computer and the communication cable are most likely good. Re-connect the serial cable to the Deckbox. If the WorkHorse still does not wakeup, there could still be a problem with the Deckbox or ADCP.

## ADCP Checks

Once you have eliminated possible problems with the power, I/O cable, communications settings, and the computer, that leaves the ADCP as the source of the problem. The following checks may help in some situations.

To Cold Start the ADCP:

1. Remove the housing to gain access to the PC boards.
2. Remove *all* power to the ADCP.



Disconnect the power cables P1 and P2 on the PIO board to ensure that NO POWER is applied to the ADCP during the next step.

3. Short TP10 to TP11 on the PIO board for 10 seconds.
4. Remove the jumper.
5. Connect the computer and connect power to the ADCP. Send a break to the ADCP. This should start the ADCP in the “cold start” mode.



To check the fuse:

Check the fuse on the PIO board is not blown (see [Fuse Replacement](#) for fuse replacement procedures).



Only fuses with the required rated current, voltage, and specified type must be used. Do not repair fuses or short circuit fuse-holders. To do so could cause a shock or fire hazard.

Check for Boot Code Error:

If the ADCP gives a steady “beep” when power is applied, the “>” prompt appears on the screen, and a “X” appears when additional breaks are sent, this may indicate that the boot code has been lost. This can happen if you abort while downloading new firmware. Try downloading the firmware again.

## Mariner Deckbox Checks

Once you have eliminated possible problems with the WorkHorse power, the serial data communication cable, and the host computer, that may leave the Deckbox as the source of the problem.



The Deckbox contains Electro Static Sensitive Devices. You must take accepted ESD prevention measures before opening the Deckbox.

To check the Deckbox:

1. One of the interconnecting cables inside the Deckbox may not be fully seated. Turn off power. Remove the top cover of the Deckbox and check that all of the cables are properly seated.
2. Check the Deckbox fuses are not blown (see [Fuse Replacement](#) for fuse replacement procedures).
3. Verify that the **Power Status** LED indicator located at the front panel next to the circuit breaker switch is lit. Make sure power to the Deckbox is connected and that the circuit breaker is in the ON position.
4. Verify that if you send push the Reset button, the **Channel 1 In** LED on the front panel lights up temporarily. If it does, that means that the serial data receive channel seems to be functioning. If it does not light up then the receive channel is not functioning.
5. If the **Channel 1 In** LED indicator on the front panel does light up while pushing **Reset**, verify that the **Channel 1 Out** LED next to it responds by lighting up temporarily as well. If the **Channel 1 Out** LED does light up, but there is no Wake-Up message displayed on the computer screen, then this indicates there is still a problem with the serial data transmit path. A serial data Break-Out box between the Deckbox and the serial communications cable would be helpful for narrowing down the problem.
6. If the Break-Out box does not indicate any data transmission from the Deckbox to the computer but the **Channel 1 Out** LED front panel indicator does, the problem most likely is with the Deckbox. Switch power to the Deckbox off, and after a few seconds on again. Repeat the Deckbox Checks from the beginning. If the system does not respond normally, it may be malfunctioning and you should contact Teledyne RD Instruments.
7. If the Break-Out box does indicate data transmission but there are no characters displayed on the computer screen, then the problem still lies with the communications cable or the computer.

# Troubleshooting a Built-In Test Failure

The built-in diagnostic tests check the major ADCP modules and signal paths. The spare boards kit may be used to repair some failures. This kit includes:

- Spare Boards including PIO board, CPU board, and DSP board (original WH) or WHP, ISM, and PIO (WHII board stack). These boards are held together with the standard M4 screw assembly and kept inside a protective anti-static bag.
- A disk containing your original beam cosine matrix table
- Tools for installation



The Spare Boards kit is not included with the system. You can order the kit by contacting Teledyne RD Instruments Customer Service department (see [How to Contact Teledyne RD Instruments](#) and Table 7, page 66).



**Do not swap individual boards between ADCPs.** Each board has individual serial numbers and calibrations that work as a set. This cannot be replicated in the field.

```
PS0                                     (example shown for a WHII board stack)
↓
Board Serial Number Data:
 57 00 00 03 8F 26 DB 23 WHP727-2022-03A
 06 00 00 03 D4 C2 F9 23 PIO727-3023-13B
 07 00 00 08 D9 09 58 09 REC727-1000-03F
↓
ISM serial number: 030000E3 23D7E86F
```

**The receiver board is not field replaceable.** The pressure sensor factory calibration is set on this board and cannot be replicated in the field.

## When to use the Spare Boards Kit

Use this Kit whenever you have any of the following problems:

- Cannot communicate to the WorkHorse and you have ensured that the serial port on the computer, WorkHorse Cable, Deckbox (Mariner only), and WorkHorse RS-232 to RS-422 converter (if applicable) are all working properly.
- Your WorkHorse fails any of the following PA tests at any time:

### CPU Tests:

- RTC
- RAM
- ROM

### DSP Tests:

- Timing RAM
- Demod RAM
- Demod REG
- FIFOs

### System Tests:

- XILINK Interrupts
- Receive Loop Back Test

- Your WorkHorse fails any of the following PA tests provided the items indicated by {} have been checked:

**Recorder Tests:**

Any recorder tests fails {provided that the Compact Flash (WHII board stack) or PCMCIA card(s) have been checked for proper installation, operation and they are DOS formatted; we STRONGLY recommend checking recorder cards in a computer before replacing the boards}

**System Tests:**

Transmit {if the WorkHorse fails when it is in water and air bubbles have been rubbed from the faces}

**Sensor Tests:**

H/W Operation {if the WorkHorse fails when it is NOT sitting/resting on its side, or located near a large magnetic field like a motor in a boat}

The spare boards kit will not correct any of the following failures:

- A damaged beam or its urethane surface
- Damage to the transducer beam connections below the copper shield
- If it passes all PA tests and yet the data is all marked as bad
- Fails the following PA test:

**System Tests:**

- Wide Bandwidth {bandwidth tests may fail due to external interference}
- Narrow Bandwidth {bandwidth tests may fail due to external interference}
- RSSI Filter
- Transmit

**Table 21: Pre-deployment Test (PA) Possible Cause of Failures**

PA Test Name	Possible Cause of Failure
Pre-Deployment Tests CPU Tests: RTC RAM ROM	WH CPU board failed WHII WHP board failed
Recorder Tests: PC Card #0 Card Detect Communication DOS Structure Sector Test (short) PC Card #1 Card Detect Communication DOS Structure Sector Test (short)	WH PC card not plugged in WH PC card failed WH DSP board failed  WHII CF card not plugged in WHII CF card failed WHII WHP board failed
DSP Tests: Timing RAM Demod RAM Demod REG FIFOs	WH DSP board failed WHII WHP board failed
System Tests: XILINX Interrupts	DSP or CPU board failed WHII WHP board failed
Receive Loop-Back	DSP or CPU board failed WHII WHP board failed
Wide Bandwidth	Not in water External interference DSP or Receiver board failed
Narrow Bandwidth	
RSSI Filter	
Transmit	Not in water or PIO board failed

Sensor Tests: H/W Operation	PIO board failed Receiver board failed Pressure sensor failed ADCP laying on its' side
--------------------------------	---

## Troubleshooting a Beam Failure

The PC1 test is designed to measure the relative noise in the environment and then have you apply more noise by rubbing the ceramics with your hand. Sometimes your hand does not generate enough noise for the system to detect. This could be due to the environment you are in or for other reasons. A simple, safe, and easy to find material that works very well as a replacement to your hand is packaging material (a.k.a. bubble wrap). Using this instead of your hand will very likely provide enough relative frictional difference for the system to pass.

If the PC1 test fails, your system may still be okay. In this case deploy the ADCP into a bucket or container of water (preferably at least 0.5 meters deep). Record some data using *TRDI Toolz* and the log file (**F3** key), or record data straight to the recorder card if your ADCP has one. Then look at the data using the *WinADCP* program and make sure that the echo amplitude counts in the 1st depth cell for all beams is between 128 and 192. If they are not, contact Field Service for further troubleshooting tips.

If the beam continuity test still fails and/or the echo amplitude indicates a problem, a bad DSP board, Receiver board, PIO board, or a bad beam may cause the failure. If replacing the DSP and PIO board (included with the spare boards kit) does not fix the problem, the ADCP must be returned to TRDI for repair.

>PC1

BEAM CONTINUITY TEST

When prompted to do so, vigorously rub the selected beam's face.

If a beam does not PASS the test, send any character to the ADCP to automatically select the next beam.

Collecting Statistical Data...

41 46 45 43 41 46 45 43 41 46 45 42 41 46 44 42

```
Rub Beam 1 = PASS | NOTE - Possible cause of failure
Rub Beam 2 = PASS | WH DSP Board or WHII WHP Board
Rub Beam 3 = PASS | Receiver Board
Rub Beam 4 = PASS | PIO Board
> | Beam
```



This test must be performed with the ADCP out of water and preferably dry.

# Troubleshooting a Sensor Failure

If the PA test fails the sensor test, run PC2 to isolate the problem. The ambient temperature sensor is mounted on the receiver board. This sensor is imbedded in the transducer head, and is used for water temperature reading. The attitude temperature sensor is located on the PIO board under the compass. The ADCP will use the attitude temperature if the ambient temperature sensor fails.

If one of the temperature sensors fails, the PC2 test will show both sensors at the same value.

```
>PC2
Press any key to quit sensor display ...

Heading   Pitch     Roll     Up/Down   Attitude Temp   Ambient Temp   Pressure
301.01°   -7.42°   -0.73°   Up        24.35°C         22.97°C       0.0 kPa
300.87°   -7.60°   -0.95°   Up        24.36°C         22.97°C       0.0 kPa
300.95°   -7.60°   -0.99°   Up        24.37°C         22.97°C       0.0 kPa
300.71°   -7.61°   -0.96°   Up        24.37°C         22.98°C       0.0 kPa
300.69°   -7.61°   -0.96°   Up        24.35°C         22.98°C       0.0 kPa
300.76°   -7.60°   -0.98°   Up        24.38°C         22.97°C       0.0 kPa
>
```



If the temperature sensor is bad, the data can still be collected with no effects to accuracy or quality. Contact TRDI about scheduling a repair of the temperature sensor at your convenience.



For external sensor verification, see [Dock Side Tests](#).

## Fault Log

To determine why a sensor failed, view the fault log. To view the fault log, start *TRDI Toolz*. Press the **End** key to wake up the ADCP. Type the following commands: **CR1**, **PA**, **FD**, **FC**. The fault log will be displayed by the FD command and is cleared by the FC command.

```
[BREAK Wakeup A]

WorkHorse Broadband ADCP Version x.xx
Teledyne RD Instruments (c) 1996-2022
All rights reserved.
[BREAK Wakeup A]
>CR1
>PA
|           (PA test results (not shown))
|
>FD
Total Unique Faults   =    2
Overflow Count        =    0
Time of first fault:  97/11/05,11:01:57.70
Time of last fault:   97/11/05,11:01:57.70

Fault Log:
Entry #  0 Code=0a08h Count=    1 Delta=    0 Time=97/11/05,11:01:57.70
Parameter = 00000000h
Tilt axis X over range.
Entry #  1 Code=0a16h Count=    1 Delta=    0 Time=97/11/05,11:01:57.70
Parameter = 00000000h
Tilt Y axis ADC under range.
End of fault log.
>FC
```

# System Overview

This section presents a functional description of WorkHorse operation using block diagrams.

## Operating Modes

The WorkHorse has two modes of operation: *command mode*, and *ping mode* (also referred to as “Deployment Saver” Mode). Depending on what mode the ADCP is in; it will go either to sleep, or to resume pinging.

### Command Mode

Whenever you wake up your WorkHorse, power dissipation increases from less than 1 mW to around 2.2 W. If you leave the WorkHorse in command mode without sending a command for more than 5 minutes, the WorkHorse automatically goes to sleep. This protects you from inadvertently depleting batteries.

- If the ADCP receives a BREAK, it will go to the command prompt and wait for a command. The ADCP will wait at the command prompt for five minutes. If no commands have been sent, it will go to sleep (also called “Battery Saver” mode).
- If you press the reset switch (located on the CPU board), the ADCP will go to sleep.
- If the ADCP receives a CS-command, it will go into the ping mode and begin pinging. If a TF-command (Time of First Ping) was sent prior to the CS-command, then the ADCP will go to sleep until the TF time occurs.
- If the ADCP does a COLD wakeup (i.e. an unknown state), it will go to the command prompt.
- If the ADCP is asleep for approximately nine hours, it wakes up to charge the capacitor used to maintain RAM. Once the capacitor is charged (this only takes a few seconds), the ADCP goes back to sleep.

### Ping Mode

After you send commands to the WorkHorse that tells it to start collecting data, the WorkHorse goes into deployment saver mode. If power is somehow removed and later restored, the WorkHorse simply picks up where it left off and continues to collect data using the same set up.

- If the ADCP receives a BREAK, it will go to the command prompt, but stays in the ping mode. If a valid command is received, the ADCP will switch to the command mode. If no valid command is received, a warning will be displayed after four minutes, indicating that the system will self-deploy. After a total of five minutes with no input, the ADCP will resume pinging.
- If you press the reset switch, and an alarm is currently set for the next ping, the ADCP will go to sleep. If no alarm is set, the system will start a new deployment and starts pinging immediately unless a TF-command had been set after the last BREAK. In this case, the ADCP will go to sleep until the TF time occurs.
- If the ADCP does a COLD wakeup, the system will start a new deployment and starts pinging immediately unless a TF-command had been set after the last BREAK. In this case, the ADCP will go to sleep until the TF time occurs if the TF time is valid (i.e., not in the past).
- If the ADCP is asleep for approximately nine hours, it wakes up to charge the capacitor used to maintain RAM. Once the capacitor is charged, if a valid alarm is set for the next ping time, the ADCP goes back to sleep and waits for the alarm. If no alarm is set, the ADCP will resume pinging immediately, or wait for the TF time (if valid), and then start pinging.



# Chapter 7

## RETURNING SYSTEMS TO TRDI FOR SERVICE



In this chapter, you will learn:

- How to pack and ship the ADCP
- How to get a RMA number
- Where to send your ADCP for repair



# Shipping the ADCP

This section explains how to ship the WorkHorse ADCP.



Remove all customer-applied coatings or provide certification that the coating is nontoxic if you are shipping a WorkHorse ADCP to TRDI for repair or upgrade. This certification must include the name of a contact person who is knowledgeable about the coating, the name, manufacturer of the coating and the appropriate telephone numbers. If you return the equipment without meeting these conditions, TRDI has instructed our employees not to handle the equipment and to leave it in the original shipping container pending certification. If you cannot provide certification, we will return the equipment to you or to a customer-specified cleaning facility. All costs associated with customer-applied coatings will be at the customer's expense.

When shipping the WorkHorse ADCP through a Customs facility, be sure to place the unit so identifying labels are not covered and can be seen easily by the Customs Inspector. Failure to do so could delay transit time.



TRDI strongly recommends using the original shipping crate whenever transporting the WorkHorse ADCP.

If you need to ship the WorkHorse ADCP, use the original shipping crate whenever possible. If the original packaging material is unavailable or unserviceable, additional material is available through TRDI.

For repackaging with commercially available materials:

1. Use a strong shipping container made out of wood or plastic.
2. Install a layer of shock-absorbing static-shielding material, 70-mm to 100-mm thick, around all sides of the instrument to firmly cushion and prevent movement inside the container.
3. Seal the shipping container securely.
4. Mark the container FRAGILE to ensure careful handling.
5. In any correspondence, refer to the WorkHorse ADCP by model and serial number.

# Returning Systems to the TRDI Factory

When shipping the system to TRDI from either inside or outside the United States, the following instructions will help ensure the WorkHorse ADCP arrives with the minimum possible delay. Any deviation from these instructions increases the potential for delay.

## Step 1 - Request a Return Material Authorization

To obtain a Return Material Authorization (RMA) number and shipping instructions for the return of your instrument, do one of the following:

- Contact Customer Service Administration at [rdicsadmin@teledyne.com](mailto:rdicsadmin@teledyne.com)
- Call +1 (858) 842-2700

When requesting a RMA number, please give us the following information:

- What is being shipped (include the serial number)
- When you plan to send the shipment
- What issue(s) need to be corrected
- Name of the Field Service Engineer that knows about the issue
- When you need the instrument returned

TRDI's Customer Service will then respond with the RMA number for the shipment. Please include this number on all packages and correspondence.

## Step 2 – Provide a MSDS as necessary

Please provide a Material Safety Data Sheet (MSDS) if the system/transducer is painted with antifouling paint.

## Step 3 - Ship via air freight, prepaid

*Urgent Shipments* should be shipped direct to TRDI via overnight or priority air services. Do not send urgent airfreight as part of a consolidated shipment. If you ship consolidated, it will cost less, but may lose up to three days in transit time.

*Non-urgent shipments* may be shipped as part of a consolidated cargo shipment to save money. In addition, some truck lines may offer equivalent delivery service at a lower cost, depending on the distance to San Diego.

Mark the Package(s)

To: Teledyne RD Instruments, Inc. (RMA Number)  
14020 Stowe Drive  
Poway, California 92064

Airport of Destination = San Diego  
UPS Supply Chain Solutions Brokerage  
15 E Oregon avenue  
Philadelphia PA 19148  
USA  
Email: [phldocreceipt@ups.com](mailto:phldocreceipt@ups.com)  
Tel: + 1 (215) 952-1745

#### Step 4 - Urgent shipments

Send the following information by telephone to TRDI.

Attention: Customer Service Administration

Phone: +1 (858) 842-2700

- Detailed descriptions of what you are shipping (number of packages, sizes, weights and contents).
- The name of the freight carrier
- Master Air bill number
- Carrier route and flight numbers for all flights the package will take

## Returning Systems to TRDI Europe Factory

When shipping the system to TRDI Europe, the following instructions will help ensure the WorkHorse ADCP arrives with the minimum possible delay. Any deviation from these instructions increases the potential for delay.

#### Step 1 - Request a Return Material Authorization

To obtain a Return Material Authorization (RMA) number and shipping instructions for the return of your instrument, do one of the following:

- Contact Customer Service Administration at [rdiefs@teledyne.com](mailto:rdiefs@teledyne.com)
- Call +33(0) 492-110-930

When requesting a RMA number, please give us the following information:

- What is being shipped (include the serial number)
- When you plan to send the shipment
- What issue(s) need to be corrected
- Name of the Field Service Engineer that knows about the issue
- When you need the instrument returned

TRDI's Customer Service will then respond with the RMA number for the shipment. Please include this number on all packages and correspondence.

#### Step 2 – Provide a MSDS as necessary

Please provide a Material Safety Data Sheet (MSDS) if the system/transducer is painted with antifouling paint.

#### Step 3 - Ship Via Air Freight, Prepaid

*Urgent Shipments* should be shipped direct to TRDI via overnight or priority air services. Do not send urgent airfreight as part of a consolidated shipment. If you ship consolidated, it will cost less, but may lose up to three days in transit time.

*Non-urgent shipments* may be shipped as part of a consolidated cargo shipment to save money.

Mark the package(s) as follows:

To: Teledyne RD Instruments, Inc. (RMA Number)  
2A Les Nertieres  
5 Avenue Hector Pintus  
06610 La Gaude, France

**Step 4 - Include Proper Customs Documentation**

The Customs statement must be completed. It should be accurate and truthfully contain the following information.

- Contents of the shipment
- Value
- Purpose of shipment (example: “American made goods returned for repair”)
- Any discrepancy or inaccuracy in the Customs statement could cause the shipment to be delayed in Customs.

**Step 5 - Send the Following Information by Telephone to TRDI**

Attention: Sales Administration

Phone: +33(0) 492-110-930

- Detailed descriptions of what you are shipping (number of packages, sizes, weights and contents).
- The name of the freight carrier
- Master Air bill number
- Carrier route and flight numbers for all flights the package will take

NOTES

# Chapter 8

## SPECIFICATIONS



In this chapter, you will learn:

- Specifications
- Outline Installation Drawings

A brief review of ADCP operation may help you understand the specifications listed in this section.



The specifications and dimensions listed in this section are subject to change without notice.

The ADCP emits an acoustic pulse called a PING. Scatterers that float ambiently with the water currents reflect some of the energy from the ping back to the ADCP. The ADCP uses the return signal to calculate a velocity. The energy in this signal is the *echo intensity*. Echo intensity is sometimes used to determine information about the scatterers.

The velocity calculated from each ping has a *statistical uncertainty*; however, each ping is an independent sample. The ADCP reduces this statistical uncertainty by averaging a collection of pings. A collection of pings averaged together is an *ensemble*. The ADCP's maximum *ping rate* limits the time required to reduce the statistical uncertainty to acceptable levels.

The ADCP does not measure velocity at a single point; it measures velocities throughout the water column. The ADCP measures velocities from its transducer head to a specified range and divides this range into uniform segments called *depth cells* (or *bins*). The collection of depth cells yields a *profile*. The ADCP produces two profiles, one for velocity, and one for echo intensity.

The ADCP calculates velocity data relative to the ADCP. The velocity data has both speed and direction information. If the ADCP is moving, and is within range of the bottom, it can obtain a velocity from returns off the bottom. This is called *bottom tracking*. The bottom track information can be used to calculate the absolute velocity of the water. The ADCP can get absolute direction information from a heading sensor.

The following tables list the specifications for the WorkHorse ADCP. About the specifications:

1. All these specifications assume minimal ADCP motion - pitch, roll, heave, rotation, and translation.
2. Except where noted, this specification table applies to typical set ups and conditions. Typical set ups use the default input values for each parameter (exceptions include Pings Per Ensemble and Number of Depth Cells). Typical conditions assume uniform seawater velocities at a given depth, moderate shear, moderate ADCP motion, and typical echo intensity levels.
3. The total measurement error of the ADCP is the sum of:
  - Long-term instrument error (as limited by instrument accuracy).
  - The remaining statistical uncertainty after averaging.
  - Errors introduced by measurement of ADCP heading and motion.
4. Because individual pings are independent, the statistical uncertainty of the measurement can be reduced according to the equation:

$$\frac{\text{Statistical Uncertainty for One Ping}}{\sqrt{\text{Number of Pings}}}$$



**Table 22: Broad Bandwidth Water Profiling**

Depth Cell Size <sup>1</sup>	Nominal range 15m <sup>2</sup> 1200 kHz			Nominal range 55m <sup>2</sup> 600 kHz			Nominal range 135m <sup>2</sup> 300k Hz			
	Vertical Resolution	Range <sup>3</sup> (m)	Single Ping Std. dev. (cm/s)	Std. dev. <sup>4</sup> (cm/s)	Range <sup>3</sup> (m)	Single Ping Std. dev. (cm/s)	Std. dev. <sup>4</sup> (cm/s)	Range <sup>3</sup> (m)	Single Ping Std. dev. (cm/s)	Std. dev. <sup>4</sup> (cm/s)
0.25m	11.27	14.43	1.93							
0.50m	12.36	7.21	0.98	38.18	14.42	1.93				
1.0m	13.67	3.60	0.50	42.01	7.21	0.99	83.25	14.43	1.92	
2.0m	15.12	1.80	0.24	46.49	3.60	0.51	92.62	7.21	0.98	
4.0m				51.50	1.80	0.25	103.66	3.60	0.50	
8.0m							116.10	1.81	0.24	

## NOTES

1. User's choice of depth cell size is not limited to the typical values specified.
2. Broad bandwidth mode is set with the WB command (WB0 by default).
3. Range, which depends on cell size, is specified here for Broad bandwidth mode at 5° C, typical ocean backscatter, and nominal 32 VDC battery power. Using 48 VDC will increase the range by 5 to 10% depending on conditions.
4. Broad bandwidth mode 50 water pings per ensemble standard deviation.
5. Table applies to WorkHorse Monitor/Sentinel/Mariner ADCPs.

**Table 23: Narrow Bandwidth Water Profiling**

Depth Cell Size <sup>1</sup>	Nominal range 15m <sup>2</sup> 1200 kHz			Nominal range 55m <sup>2</sup> 600 kHz			Nominal range 135m <sup>2</sup> 300 kHz			
	Vertical Resolution	Range <sup>3</sup> (m)	Single Ping Std. dev. (cm/s)	Std. dev. <sup>4</sup> (cm/s)	Range <sup>3</sup> (m)	Single Ping Std. dev. (cm/s)	Std. dev. <sup>4</sup> (cm/s)	Range <sup>3</sup> (m)	Single Ping Std. dev. (cm/s)	Std. dev. <sup>4</sup> (cm/s)
0.25m	14.74	27.69	3.77							
0.50m	15.97	13.82	1.93	52.02	29.75	4.04				
1.0m	17.41	6.89	0.98	56.33	14.86	2.07	117.42	29.76	4.02	
2.0m	18.96	3.45	0.48	61.27	7.40	1.06	128.11	14.86	2.05	
4.0m				66.72	3.70	0.51	140.63	7.41	1.05	
8.0m							154.39	3.72	0.52	

## NOTES

1. User's choice of depth cell size is not limited to the typical values specified.
2. Narrow bandwidth mode is set with the WB command (WB1).
3. Range, which depends on cell size, is specified here for Narrow bandwidth mode at 5° C, typical ocean backscatter, and nominal 32 VDC battery power. Using 48 VDC will increase the range by 5 to 10% depending on conditions.
4. Narrow bandwidth mode 50 water pings per ensemble standard deviation.
5. Table applies to WorkHorse Monitor/Sentinel/Mariner ADCPs.

**Table 24: WorkHorse Range**

Frequency	Range (m) @ 32VDC	Range (m) @ 48VDC	Depth Cell Size (m)
1200kHz	18.96	20.4	2
600kHz	66.72	70.9	4
300kHz	140.63	167.7	8

Range, which depends on cell size, is specified here for narrow bandwidth mode at 5° C, typical ocean backscatter, and nominal 32 VDC battery power (Sentinel) and 48VDC input power (Mariner/Monitor).

**Table 25: Bottom Track Profile Parameters**

System Frequency	1200 kHz	600 kHz	300 kHz
Maximum Altitude (m)*	28	100	260
Minimum Altitude (m)	0.8 (Mariner)	1.4 (Mariner)	2

\* @ 48VDC input power.

**Table 26: Bottom Track Velocity (for |V| < 10 m/s)**

Precision (cm/s)*	1200 kHz	600 kHz	300 kHz
V=1.0 m/s	0.5	0.4	0.5
V=3.0 m/s	0.8	0.7	1.0
V=5.0 m/s	1.0	1.0	1.4
BT-BA (Base Accuracy) (cm/s)	±1.15% ± 0.4	±1.15% ± 0.4	±1.15% ± 0.4
BT-HA (High Accuracy) (cm/s)	±0.4% ± 0.4	±0.4% ± 0.4	±0.4% ± 0.4
Maximum Ping Rate**	1 to 10 Hz	0.5 to 7 Hz	0.5 to 7 Hz

\* Water and Bottom velocity precision are standard deviations of horizontal velocities for single pings. The standard deviation for an ensemble of pings will decrease proportional to the square root of the number of pings averaged together.

\* Single Ping Precision calculated for an altitude of one-half maximum altitude for a given frequency.

\*\* Ping rates vary due to altitude, baud rate, and amount of water profiled.



BT-BA (Base Accuracy 1.15%) Bottom Track (Export-Compliant) and BT-HA (High Accuracy 0.4%) Bottom Track modes are mutually exclusive. Only one may be enabled.

**Table 27: Profile Parameters**

Item	Specification
Velocity accuracy	
1200 and 600 kHz	± 0.3% of the water velocity relative to the ADCP ± 3mm/s
300 kHz	± 0.5% of the water velocity relative to the ADCP ± 5mm/s
Velocity resolution	1 mm/s
Velocity range	± 5m/s (default), ± 20m/s (maximum)
Number of depth cells	1 to 255
Ping rate	2 Hz (typical)

**Table 28: Echo Intensity Profile**

Item	Specification
Vertical resolution	Depth cell size
Dynamic range	80 dB
Precision	± 1.5dB (relative measure)

**Table 29: Standard Sensors – Original WH Electronics**

Temperature (Transducer Mounted)	
Range	-5° to 45° C
Uncertainty	±0.4° C
Resolution	0.01°
Tilt	
Range	±15°
Uncertainty	±0.5° (up to 15°)
Precision	± 0.5°
Resolution	0.01°
Compass <sup>(1)</sup>	
Type	flux gate
Long-term accuracy	±2° @ 60° magnetic dip angle, 0.5G total field
Precision	± 0.50 @ 60° magnetic dip angle, 0.5G total field
Resolution	0.01°
Max tilt	± 15°
Optional Pressure Sensor <sup>(2)</sup>	
Available Pressure Ratings	1, 2, 5, 10, 20, 50, 100, 200, 400, 500, or 1000 BAR
Short-term uncertainty	±0.1%
Max. drift	±0.25%



1. Includes built-in field calibration procedure. Compass uncertainty is for tilts less than 15°.
2. Other pressure ratings may be special-ordered.

**Table 30: Standard Sensors – WHII Electronics**

Temperature (Transducer Mounted)	
Range	-5° to 45° C
Uncertainty	±0.4° C
Resolution	0.01°
ISM Compass	
Heading Accuracy	1°RMS <sup>Note 1</sup>
Resolution	0.1°
ISM Tilt Sensors	
Range	±90°
Tilt Accuracy	±0.3° <sup>Note 2</sup>
Resolution	0.06°
Pressure Sensor	
Available Pressure Ratings	20 or 600 BAR
Short-term uncertainty	±0.1%
Max. drift	±0.25%



1. Heading Accuracy after Field Calibration: Calibration with >0.45 Gauss total field and <70° dip angle, ±70° combined tilt.
2. Long term Pitch/Roll Accuracy, <±70° combined tilt.

**Table 31: Transducer and Hardware**

Item	Specification
Beam angle	20°
Configuration	4 beam, convex
Internal memory	WH memory card not included with Monitor and Mariner models. Sentinel ADCPs come standard with one memory card. Two PCMCIA memory card slots are available. The maximum memory for each slot is 2GB, with the total memory capacity not to exceed 4GB.  WHII ADCPs include one Delkin C600 series CompactFlash card, with the maximum memory capacity not to exceed 4GB per deployment.
Communications	Serial port selectable by switch for RS-232 or RS-422. ASCII or binary output at 1200 to 115,200 baud.

**Table 32: Environmental Specifications**

Item	Specification
Operating temperature with or without batteries	-5° to 45°C
Short Term Storage/Shipping (<45days) temperature (Batteries Installed)	-5° to 45°C
Long Term Storage (>45days) temperature (Batteries Installed)	0° C to 21° C
Long Term Storage (>45days) temperature (Batteries Removed)	-30° to 60°C
Long Term (>45days) Battery Storage	Batteries should be stored in cool dry air with a temperature range of 0° C to 21° C
Battery Shelf Life	Use within one year



Do not deploy the system with batteries that are older than the Warning date. It should be noted, that while a battery pack will not be dead after the Warning date, the actual performance of the battery is in doubt and may not have sufficient capacity for the deployment.



TRDI batteries have four dates on them:

**Manufacture Date** is the date the battery was built and final tested.

**TRDI Ship by Date** provides the maximum duration that the battery will remain on our shelves before we will ship and is 6 months after our manufacture date.

**Warning Do not Deploy After Date\*** provides the last date when the battery should be used to start a deployment and is 12 months from the manufacture date.

**Expiration Date** provides the date when the battery should no longer be considered useful and is 2 years from the manufacture date.

\*A battery pack used to start a deployment prior to the Warning Date means that it will perform as expected and provide the required power for any deployment that was created using the TRDI planning module. For example, if your deployment is going to be 12 months long and the battery label shows it is nine months old, it is safe to use the battery.

**Table 33: Power**

System	Specification
<b>Sentinel</b>	
DC input	20 to 50 VDC external power supply
Battery Voltage	42 VDC (new), 28 VDC (depleted)
Battery Capacity	450 watt hours @ 0° C
External Battery Pack	42 VDC (new), 28 VDC (depleted). Holds up to two 450 watt hour batteries
Transmit	16W @ 35V (1200kHz), 37W @ 35V (600kHz), 115W @ 35V (300kHz)
<b>Monitor</b>	
DC input	20 to 50 VDC external power supply or 42 VDC External Battery Pack
Transmit	22W @ 48V (1200kHz), 60W @ 48V (600kHz), 190W @ 48V (300kHz)
<b>Mariner</b>	
Deckbox Input	12 VDC, 20 to 50V DC external power supply, 110 to 220 VAC
Transmit	22W @ 48V (1200kHz), 60W @ 48V (600kHz), 190W @ 48V (300kHz)

**Table 34. Lithium Battery Specifications**

Temperature	Capacity (Whr)
0° C	1350
10° C	1500
20° C	1650
37° C	1450

Nominal voltage: 34 VDC

Weight: 2.8 kg

Self-discharge: 0.7%/year (10 year old packs hold 93% of their original capacity)

# Outline Installation Drawings

The following drawings show the standard WorkHorse Monitor, Sentinel, Mariner, and Mariner Deckbox dimensions and weights.

**Table 35: Outline Installation Drawings**

Description	Drawing #	Revision
Mariner Deckbox	961-6031	C
External Battery Case	967-6007	C
6000 meter External Battery Case	967-4001	XG
1200 kHz Mariner	967-6032	E
300/600 kHz Mariner	967-6033	E
1200 kHz Monitor/Sentinel	967-6034	D
300/600 kHz Monitor/Sentinel	967-6035	G
300/600 kHz 500 meter Monitor/Sentinel	967-6044	B
1200 kHz 500 meter Monitor/Sentinel	967-6045	B
6000 meter 1200kHz Sentinel	967-6012	B
6000 meter 300kHz Sentinel	967-6113	A
6000 meter 600kHz Sentinel	967-6114	XD
6000 meter 300kHz Monitor	967-6115	XD
6000 meter 1200kHz Sentinel	967-6103	XB
1000 meter 300kHz Monitor/Sentinel	967-9006	XB
1000 meter 1200kHz Sentinel	967-6146	XB
6000 meter 300 kHz, 4 battery pack	967-6159	A

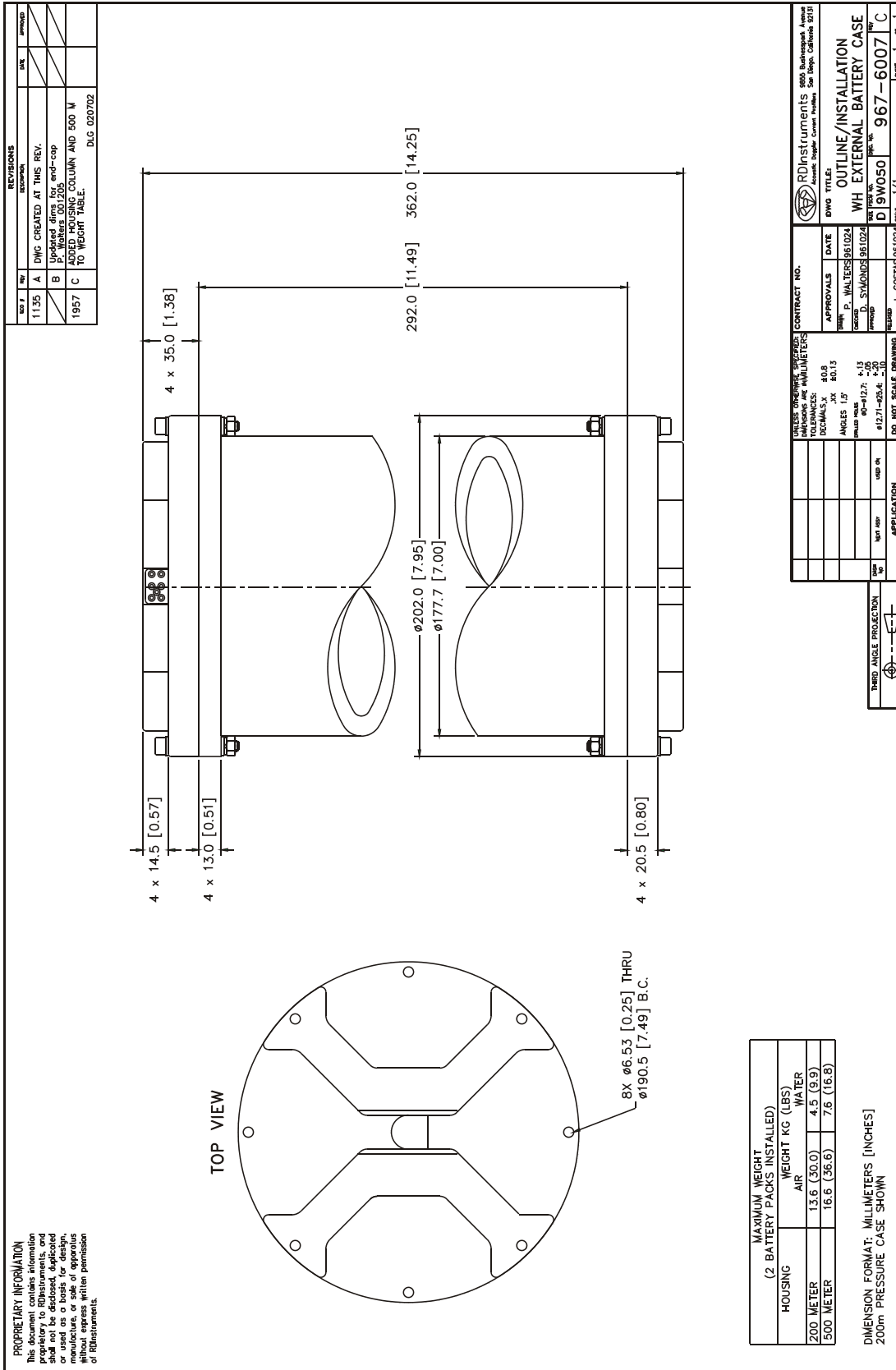


Outline Installation Drawings are subject to change without notice. Verify you have the latest version of the drawing by contacting TRDI before building mounts or other hardware.

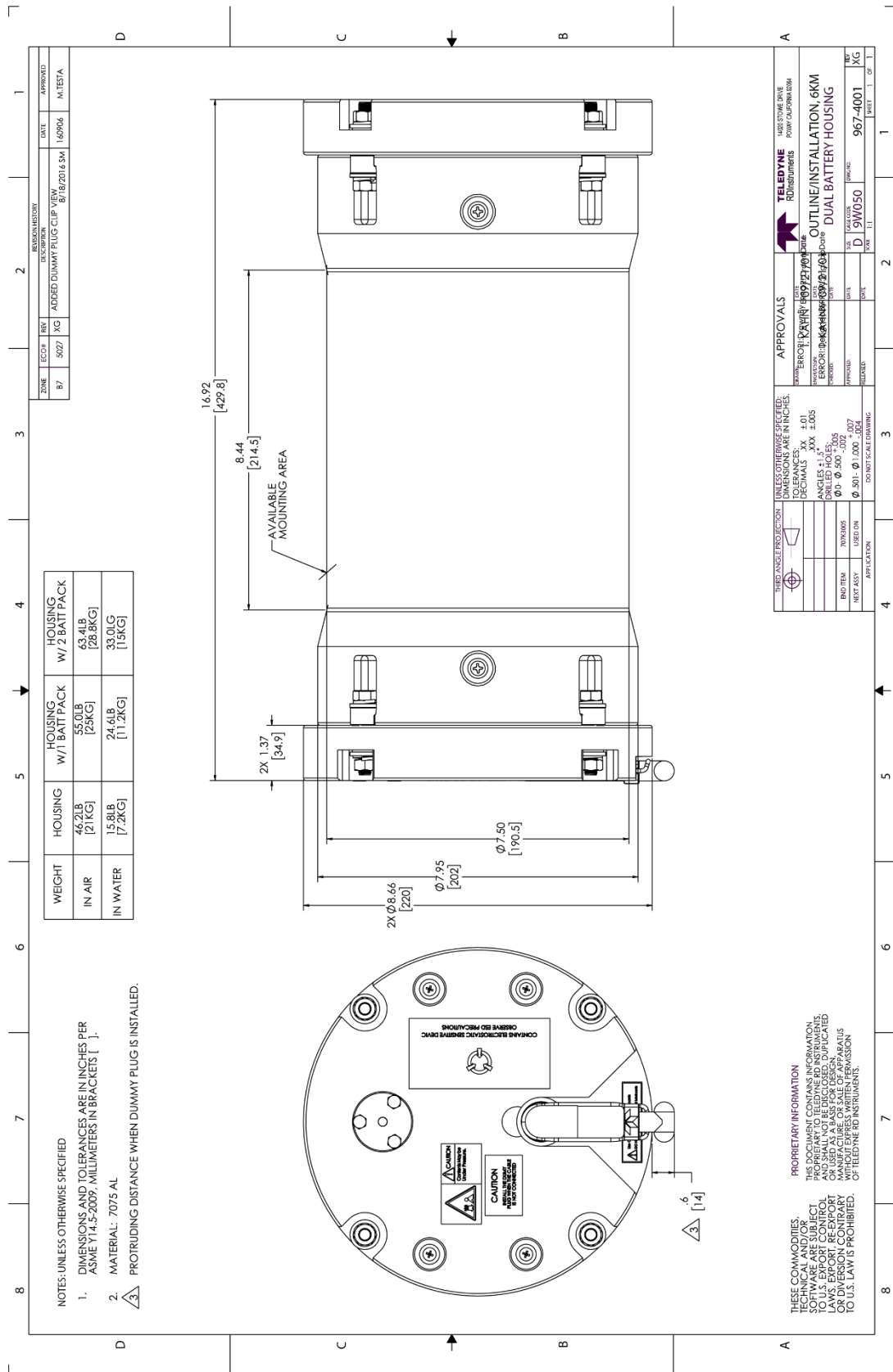




967-6007



967-4001

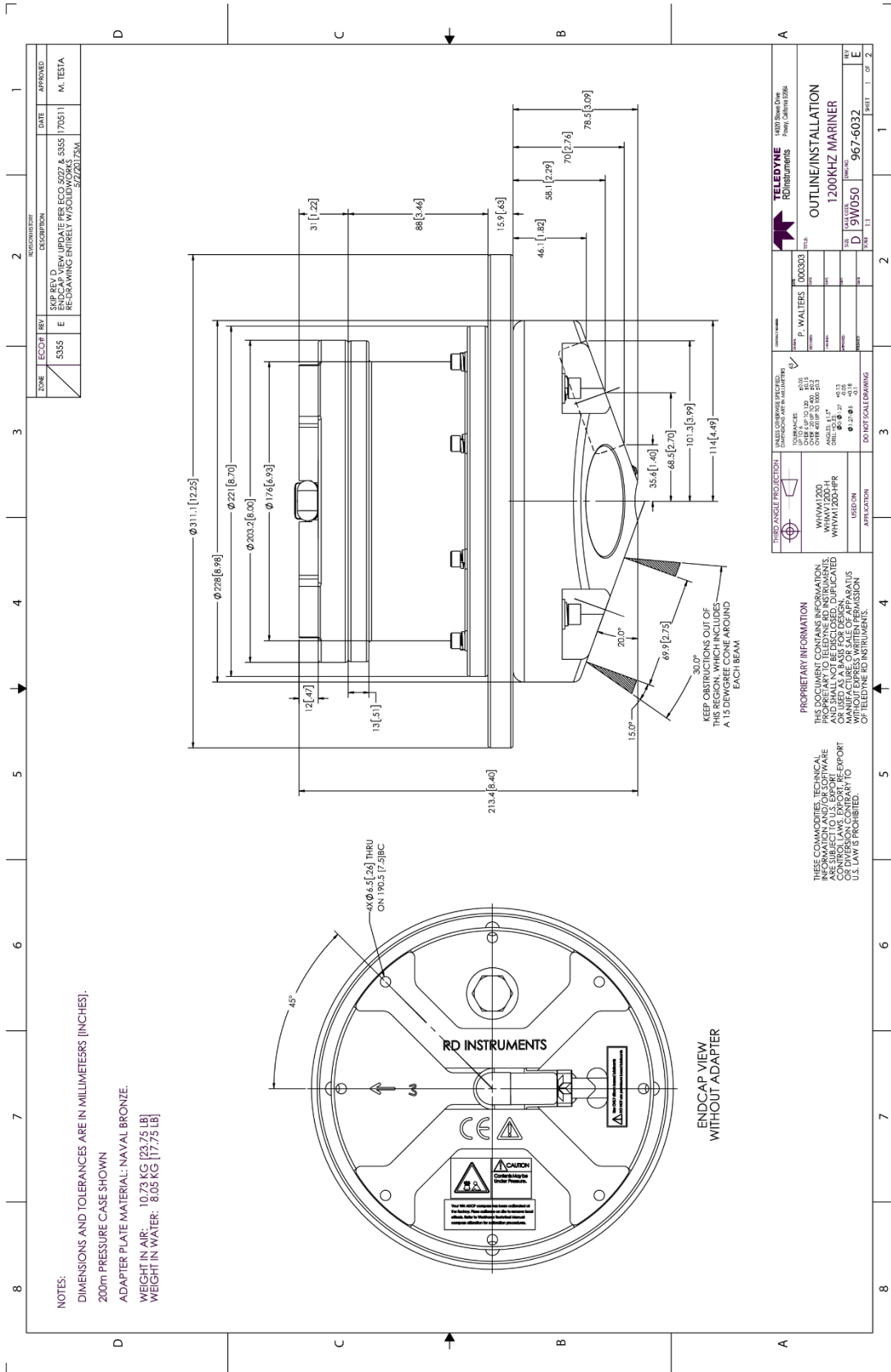


WEIGHT	HOUSING	HOUSING W/1 BATT PACK	HOUSING W/ 2 BATT PACK
IN AIR	46.2LB [21 KG]	55.0LB [25KG]	63.4LB [28.8KG]
IN WATER	15.8LB [7.2KG]	24.4LB [11.2KG]	33.0LB [15KG]

- NOTES: UNLESS OTHERWISE SPECIFIED
- DIMENSIONS AND TOLERANCES ARE IN INCHES PER ASME Y14.5-2009; MILLIMETERS IN BRACKETS [ ].
  - MATERIAL: 7075 AL
  - PROTRUDING DISTANCE WHEN DUMMY PLUG IS INSTALLED.

<b>TELEDYNE</b> RESEARCH CORPORATION 967-4001		USE STATE ONE FORM CALIFORNIA	
APPROVALS DESIGNER: [Signature] DATE: 8/27/2024 CHECKED: [Signature] DATE: 8/27/2024 APPROVED: [Signature] DATE: 8/27/2024		OUTLINE/INSTALLATION, 6KM DUAL BATTERY HOUSING	
UNLESS OTHERWISE SPECIFIED: DIMENSIONS ARE IN INCHES. DECIMALS: .XX ±.01 ANGLES: .XXX ±.005 HOLE TYPES: DRILLED HOLES: Ø - Ø .000 ±.002 Ø .501 - Ø 1.000 ±.007		APPLICATION: DUAL BATTERY HOUSING DRAWING NO: 967-4001 REV: 1.1 DATE: 8/27/2024	
THIRD ANGLE PROJECTION DIMENSIONS ARE IN INCHES. UNLESS OTHERWISE SPECIFIED: DECIMALS: .XX ±.01 ANGLES: .XXX ±.005 HOLE TYPES: DRILLED HOLES: Ø - Ø .000 ±.002 Ø .501 - Ø 1.000 ±.007		TOLERANCES: DECIMALS: .XX ±.01 ANGLES: .XXX ±.005 HOLE TYPES: DRILLED HOLES: Ø - Ø .000 ±.002 Ø .501 - Ø 1.000 ±.007	

967-6032 Sheet 1



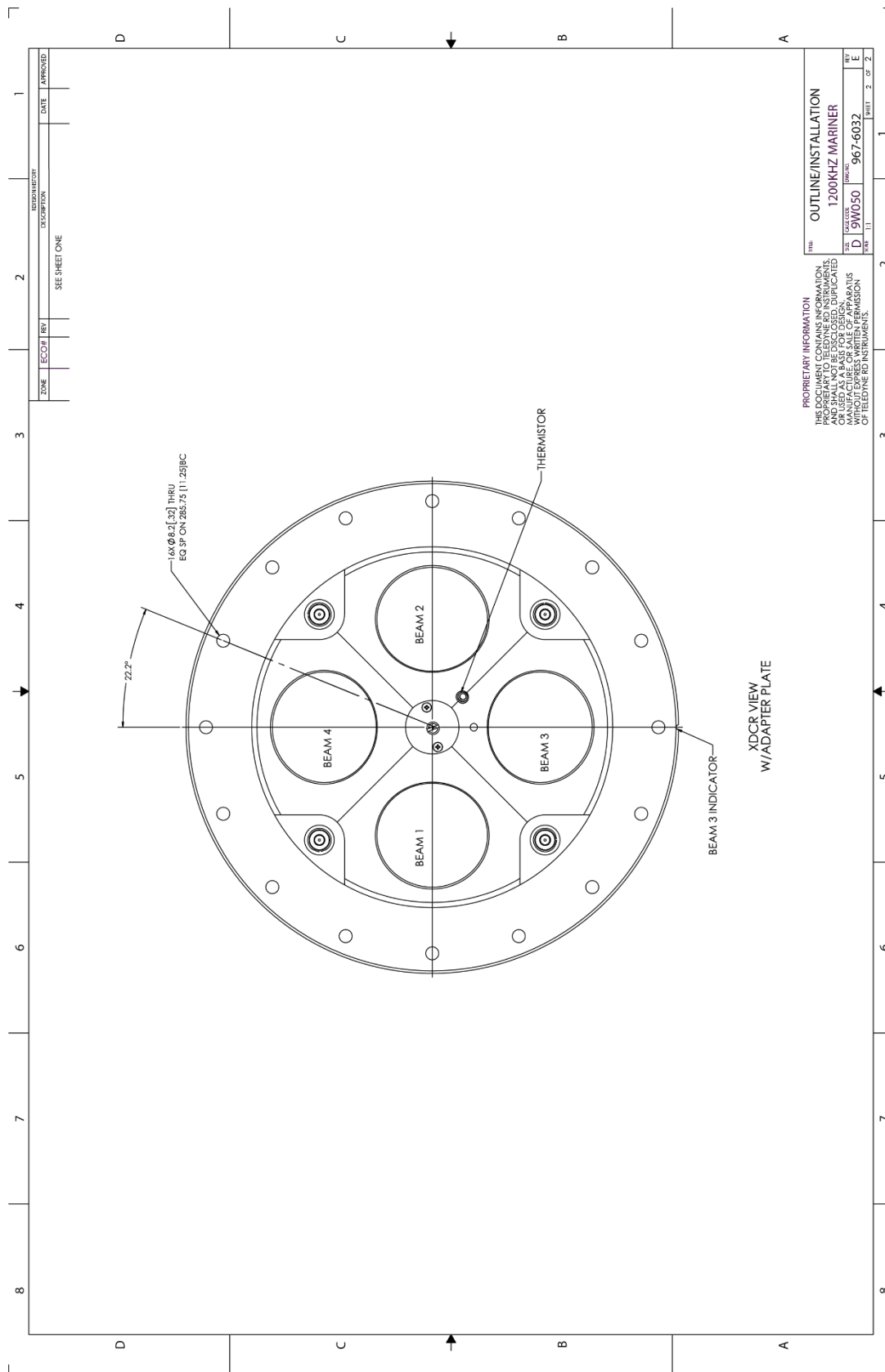
ZONE	ECO#	REV	DESCRIPTION	DATE	APPROVED
	5335	E	SHIP REV D ENDCAP VIEW UPDATE PER ECO 5297 & 5335 REDRAWING ENTIREY W/ SOLIDWORKS	7/05/11	M. TESTA

		<b>RD Instruments</b> 1400 Shasta Drive Fremont, California 94566	
TITLE: <b>OUTLINE/INSTALLATION</b> <b>1200KHZ MARINER</b>	PART NO: <b>D 957-6032</b> REV: <b>1.1</b>	DESIGNED BY: <b>P. WALTERS</b> DRAWN BY: <b>D00303</b> CHECKED BY: <b>D00303</b> DATE: <b>08/20/2013</b>	SCALE: <b>1:1</b> SHEET: <b>1</b> OF <b>2</b>

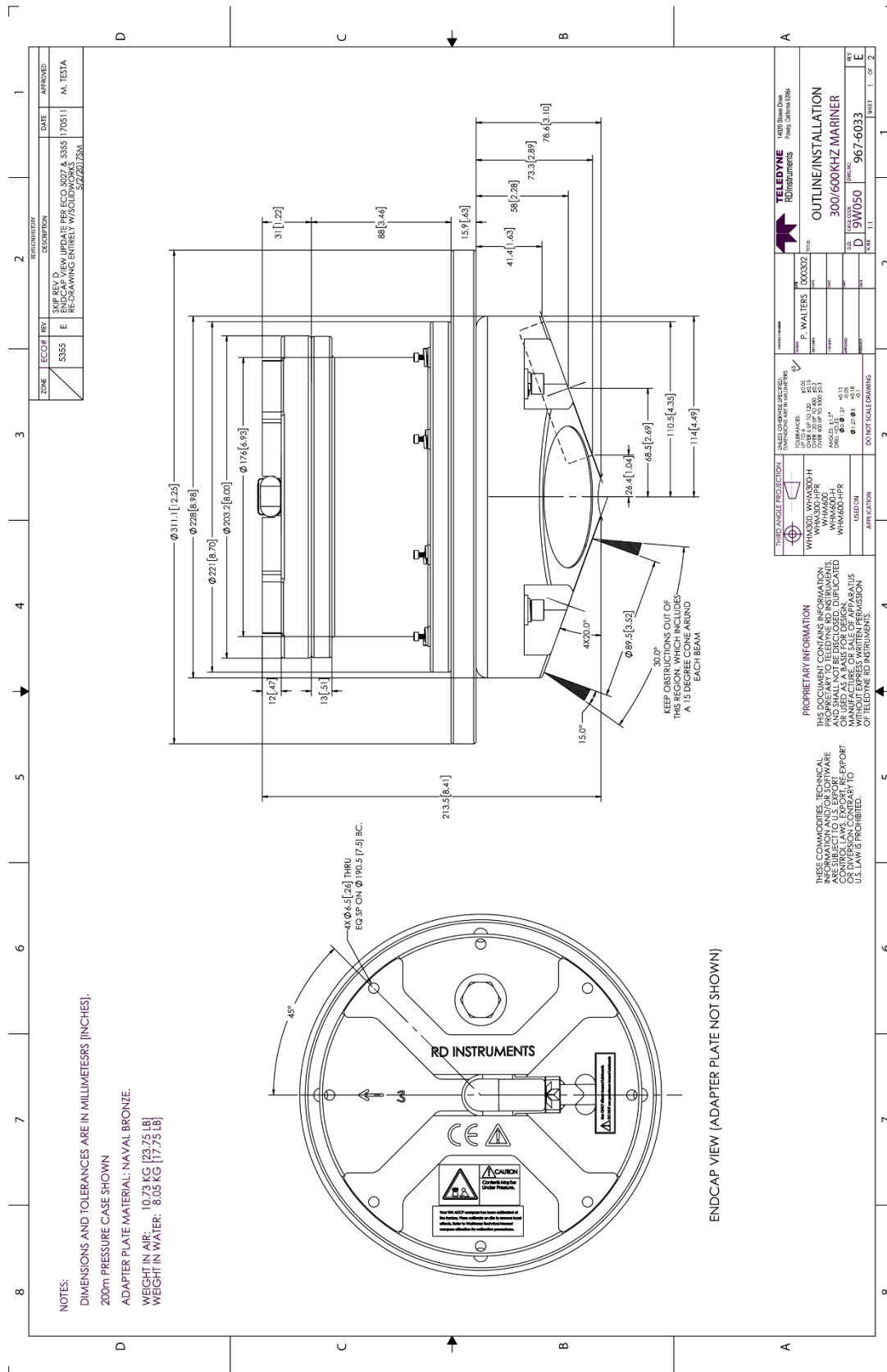
THESE COMMODITIES, TECHNICAL INFORMATION AND/OR SOFTWARE ARE UNCLASSIFIED EXCEPT WHERE SHOWN OTHERWISE. CONTROL LAWS, EXPORT, REEXPORT OR DIVERSION CONTRARY TO U.S. LAW IS PROHIBITED.	PROPRIETARY INFORMATION THIS DOCUMENT CONTAINS INFORMATION PROPRIETARY TO TELEDYNE RD INSTRUMENTS. IT IS NOT TO BE REPRODUCED, COPIED, OR TRANSMITTED IN ANY FORM OR BY ANY MEANS, ELECTRONIC OR MECHANICAL, INCLUDING PHOTOCOPYING, RECORDING, OR BY ANY INFORMATION STORAGE AND RETRIEVAL SYSTEM, WITHOUT THE WRITTEN PERMISSION OF TELEDYNE RD INSTRUMENTS.
---	---

THESE COMMODITIES, TECHNICAL INFORMATION AND/OR SOFTWARE ARE UNCLASSIFIED EXCEPT WHERE SHOWN OTHERWISE. CONTROL LAWS, EXPORT, REEXPORT OR DIVERSION CONTRARY TO U.S. LAW IS PROHIBITED.	THESE COMMODITIES, TECHNICAL INFORMATION AND/OR SOFTWARE ARE UNCLASSIFIED EXCEPT WHERE SHOWN OTHERWISE. CONTROL LAWS, EXPORT, REEXPORT OR DIVERSION CONTRARY TO U.S. LAW IS PROHIBITED.
---	---

967-6032 Sheet 2



967-6033 Sheet 1



ZONE	ECO#	REV	DESCRIPTION	DATE	APPROVED
	5335	E	ENDCAP VIEW UPDATE PER ECO 5297 & 5355 / 7/05/11 RE-DRAWING ENTIRE P/W ASSEMBLY 5/27/2012/M.		M. TESTA

<b>TELEDYNE</b> RD Instruments 1400 Street Drive Folsom, California 95688	
DESIGNER	P. WALTERS
DATE	000307
SCALE	
TITLE	OUTLINE/INSTALLATION 300/600KHZ MARINER
PROJ.#	D 19W050
REV	1.1
SHEET	1 OF 2

UNLESS OTHERWISE SPECIFIED: DIMENSIONS ARE IN MILLIMETERS DIMENSIONS IN PARENTHESIS ARE IN INCHES	UNITS: MILLIMETERS UNITS: INCHES TOLERANCES: FRACTIONS DECIMALS HOLE POSITION ±0.10 ±0.25 OTHER POSITION ±0.20 ±0.51 ANGLES ±1.0° ±0.5° SURFACE FINISH: UNLESS OTHERWISE SPECIFIED: HOLE SURFACE: 12.5 OTHER SURFACES: 3.2
---	--

THIRD ANGLE PROJECTION

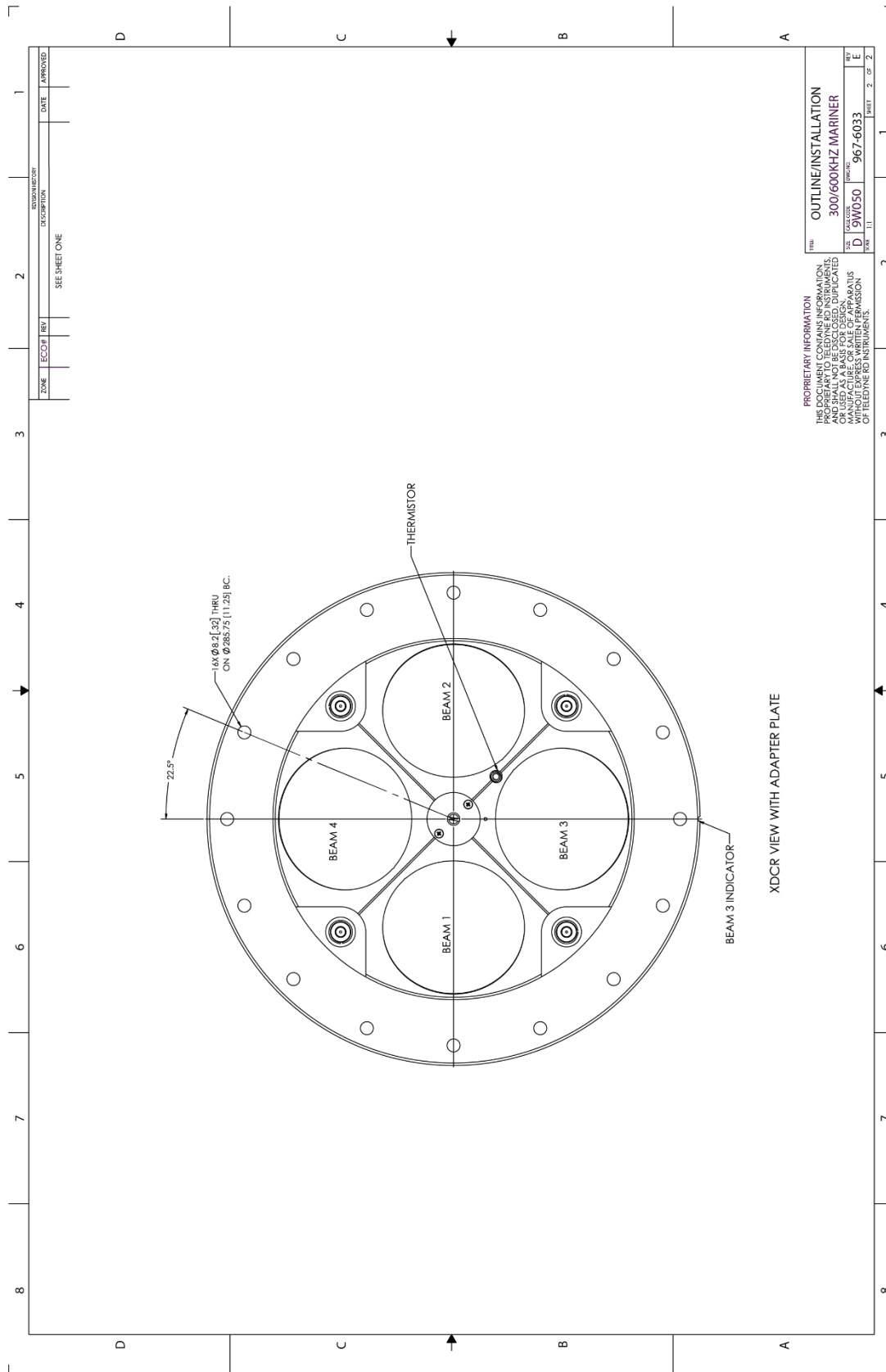
WHM600-HPR  
 WHM600-HPR  
 WHM600-HPR  
 WHM600-HPR

PROPRIETARY INFORMATION  
 THE DOCUMENT CONTAINS INFORMATION  
 PROPRIETARY TO TELEDYNE RD INSTRUMENTS.  
 THIS DOCUMENT IS UNCLASSIFIED  
 UNLESS INDICATED OTHERWISE.  
 REPRODUCTION OR SALE OF APPARATUS  
 OR DIVERSION CONTRARY TO  
 U.S. LAW IS PROHIBITED.

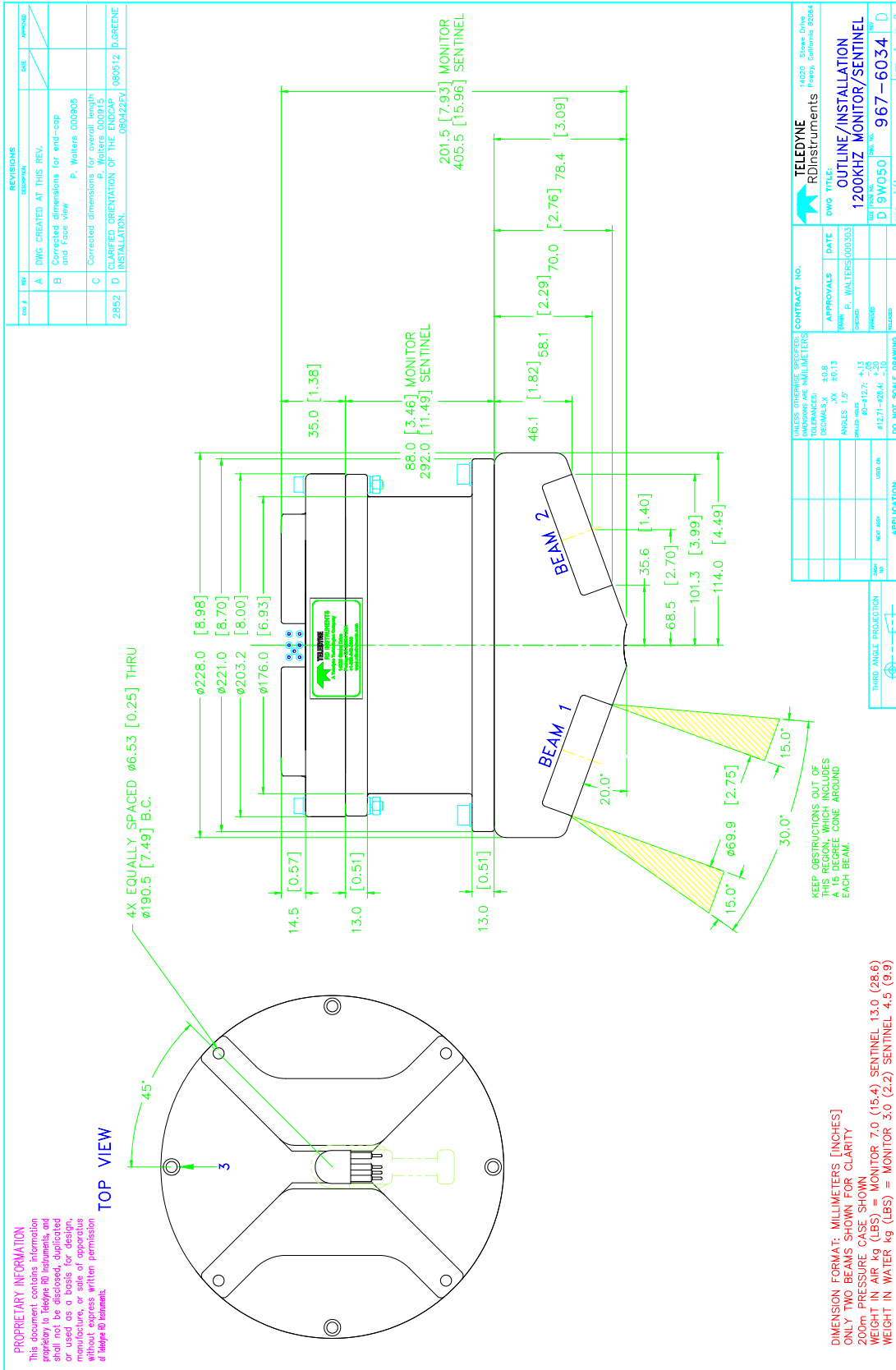
KEEP OBSTRUCTIONS OUT OF  
 THIS REGION WHICH INCLUDES  
 A 15 DEGREE MARGIN  
 EACH BEAM

4x20.0°  
 30.0°  
 15.0°

967-6033 Sheet 2

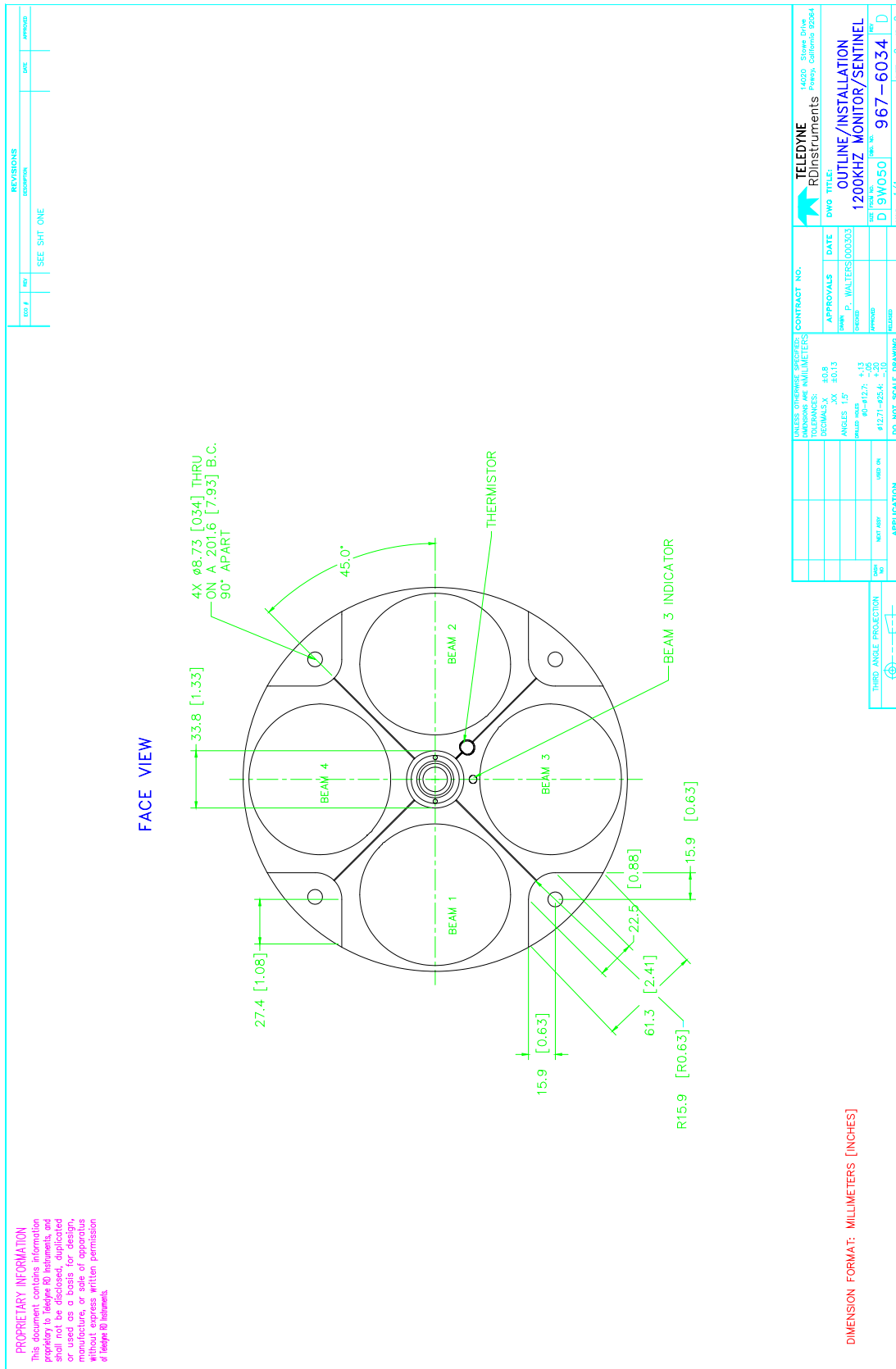


967-6034 Sheet 1



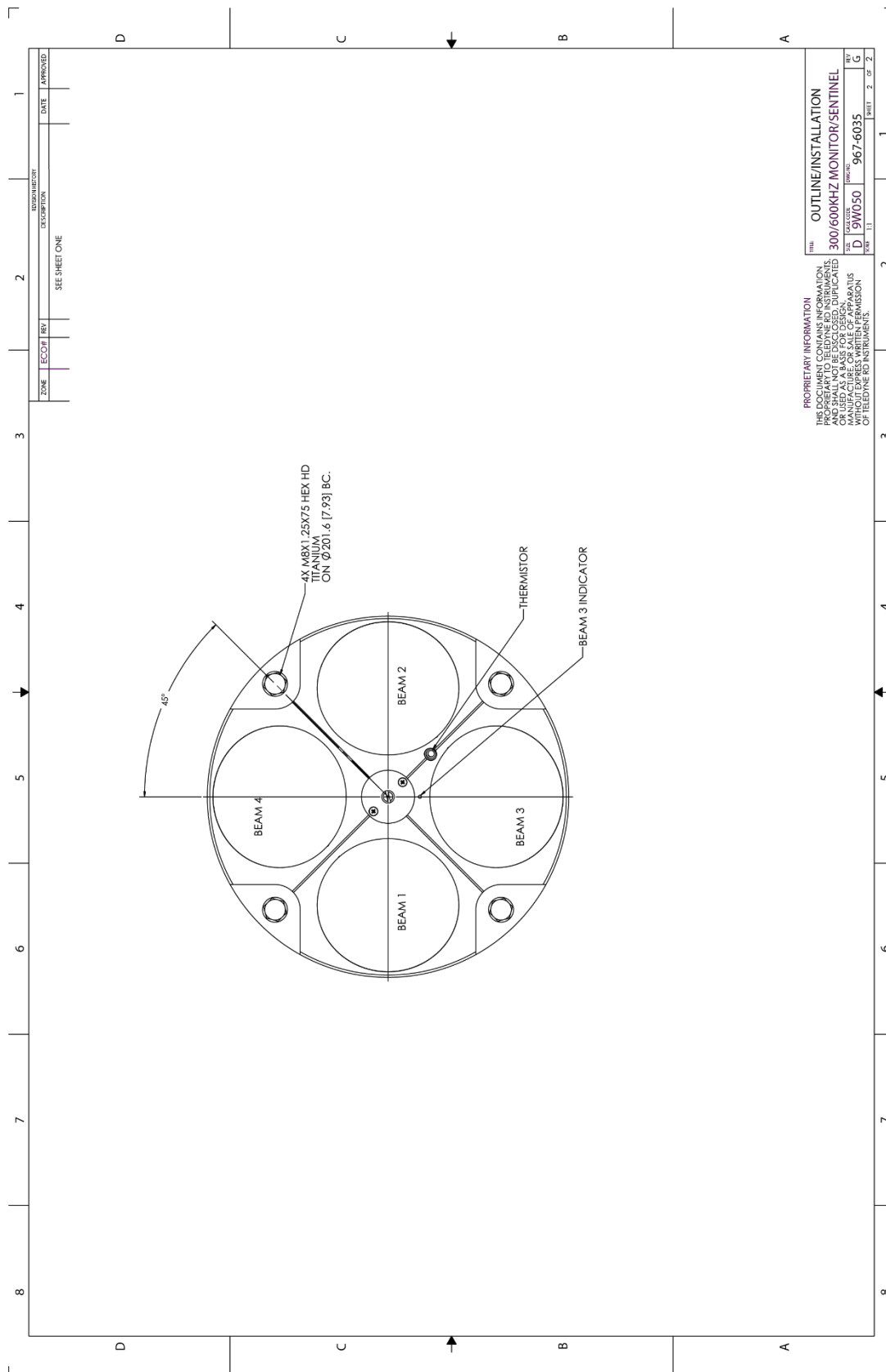


967-6034 Sheet 2





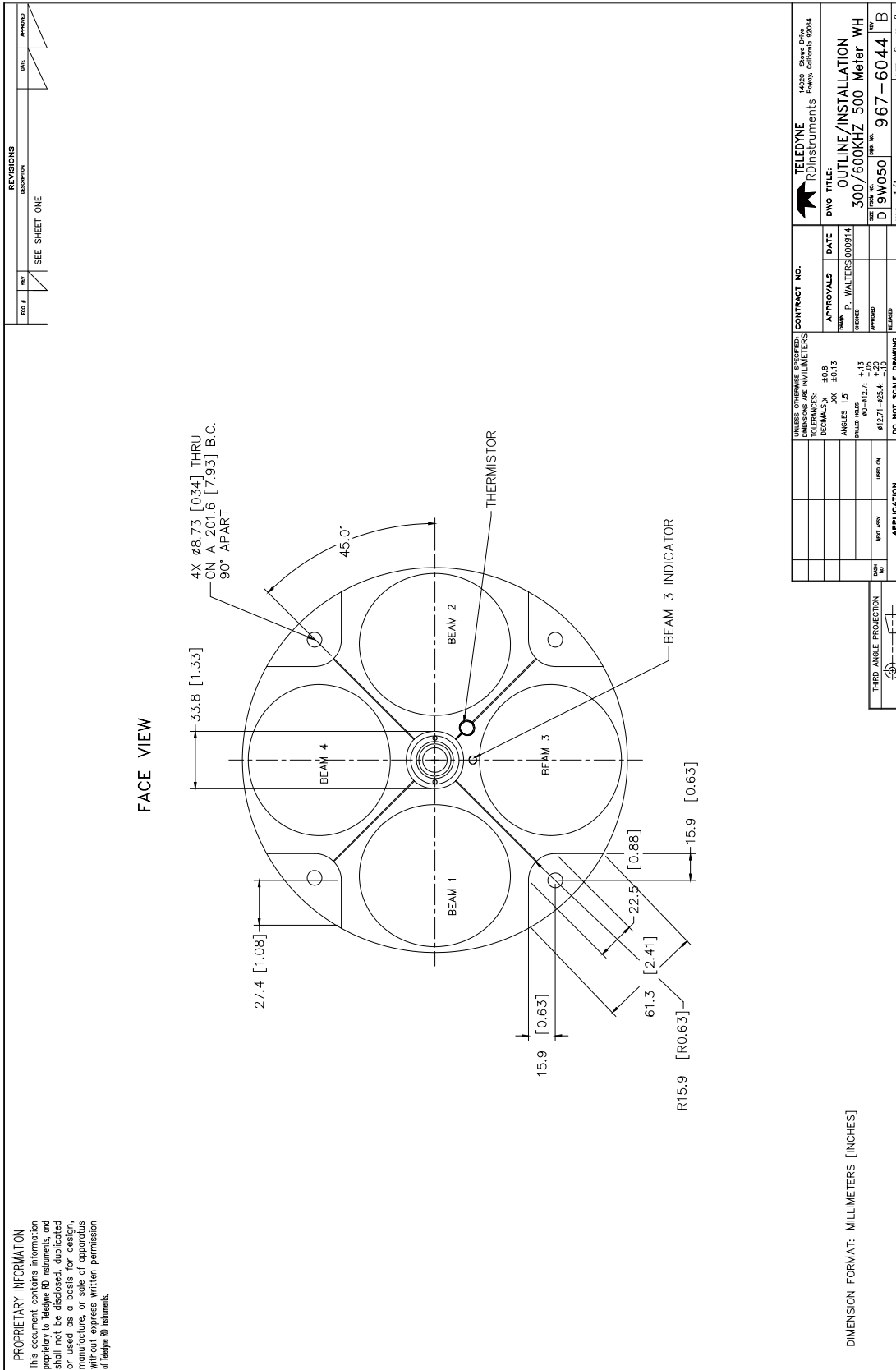
967-6035 Sheet 2



PROPRIETARY INFORMATION  
 THE CONTENTS OF THIS DOCUMENTATION  
 ARE THE PROPERTY OF TELEDYNE INSTRUMENTS  
 AND SHALL NOT BE REPRODUCED, COPIED,  
 OR TRANSMITTED IN ANY FORM OR BY ANY  
 MEANS, ELECTRONIC OR MECHANICAL,  
 INCLUDING PHOTOCOPYING, RECORDING,  
 OR BY ANY INFORMATION STORAGE AND  
 RETRIEVAL SYSTEM, WITHOUT THE WRITTEN  
 PERMISSION OF TELEDYNE INSTRUMENTS.

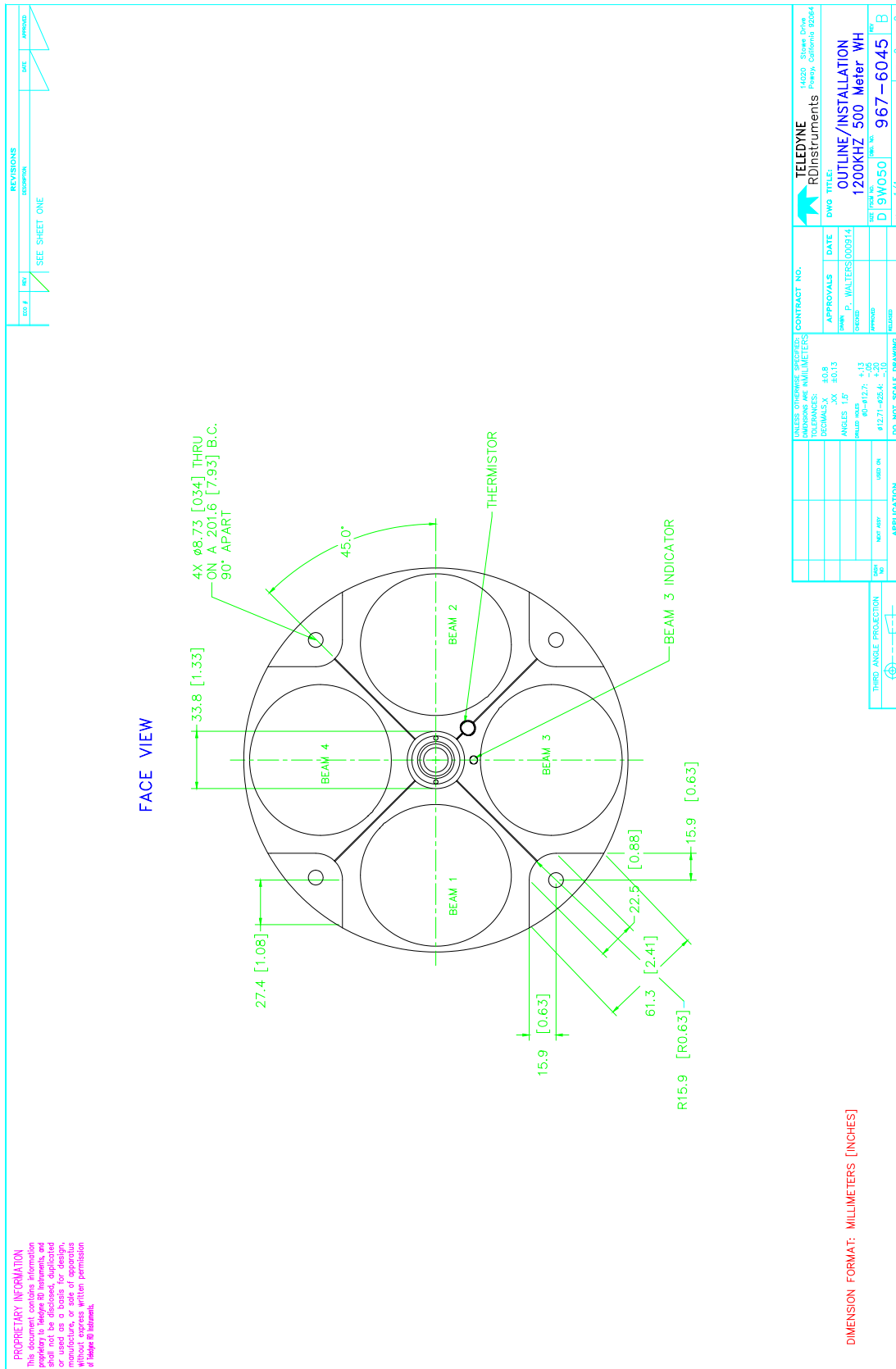


967-6044 Sheet 2



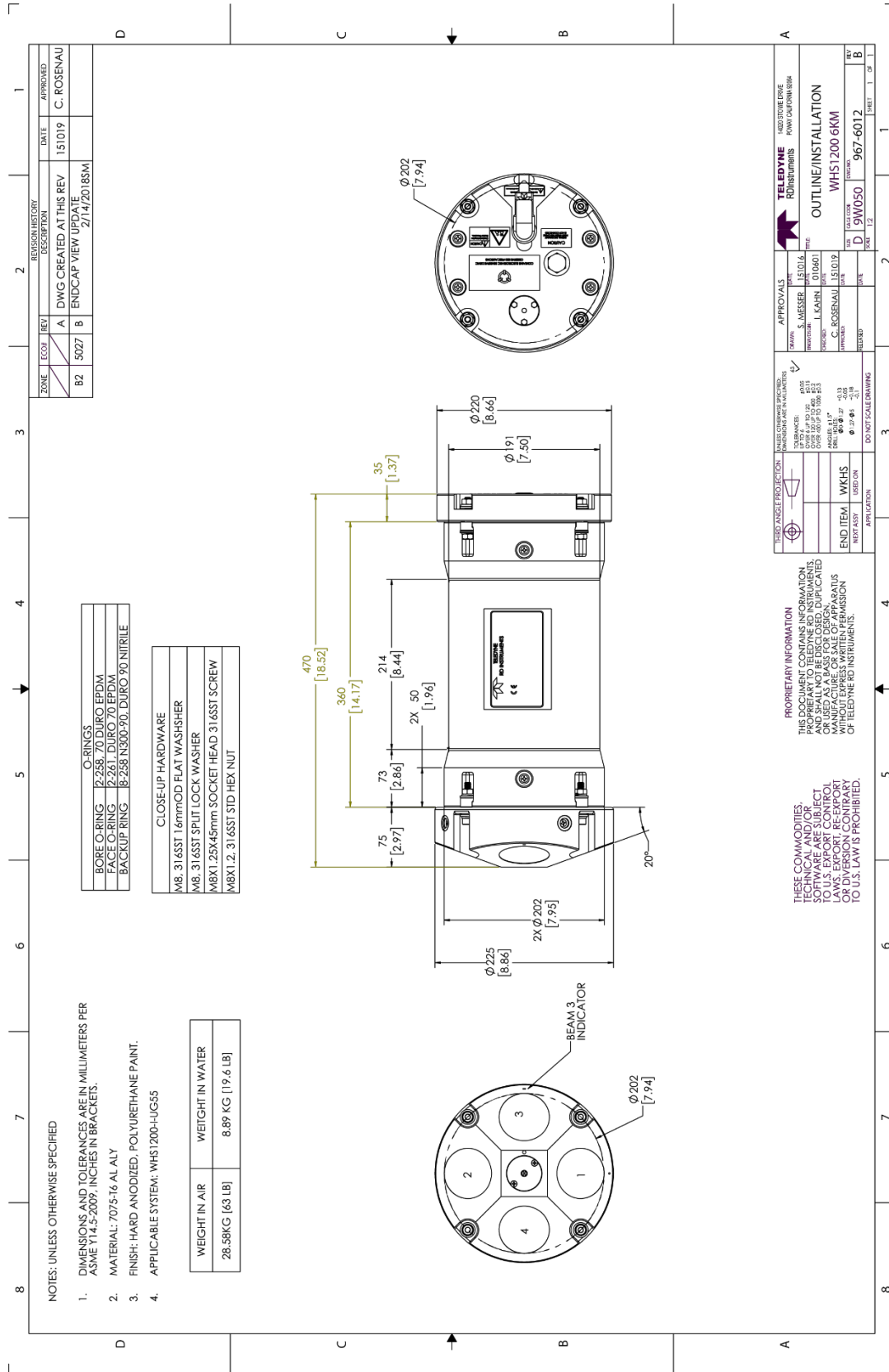


967-6045 Sheet 2

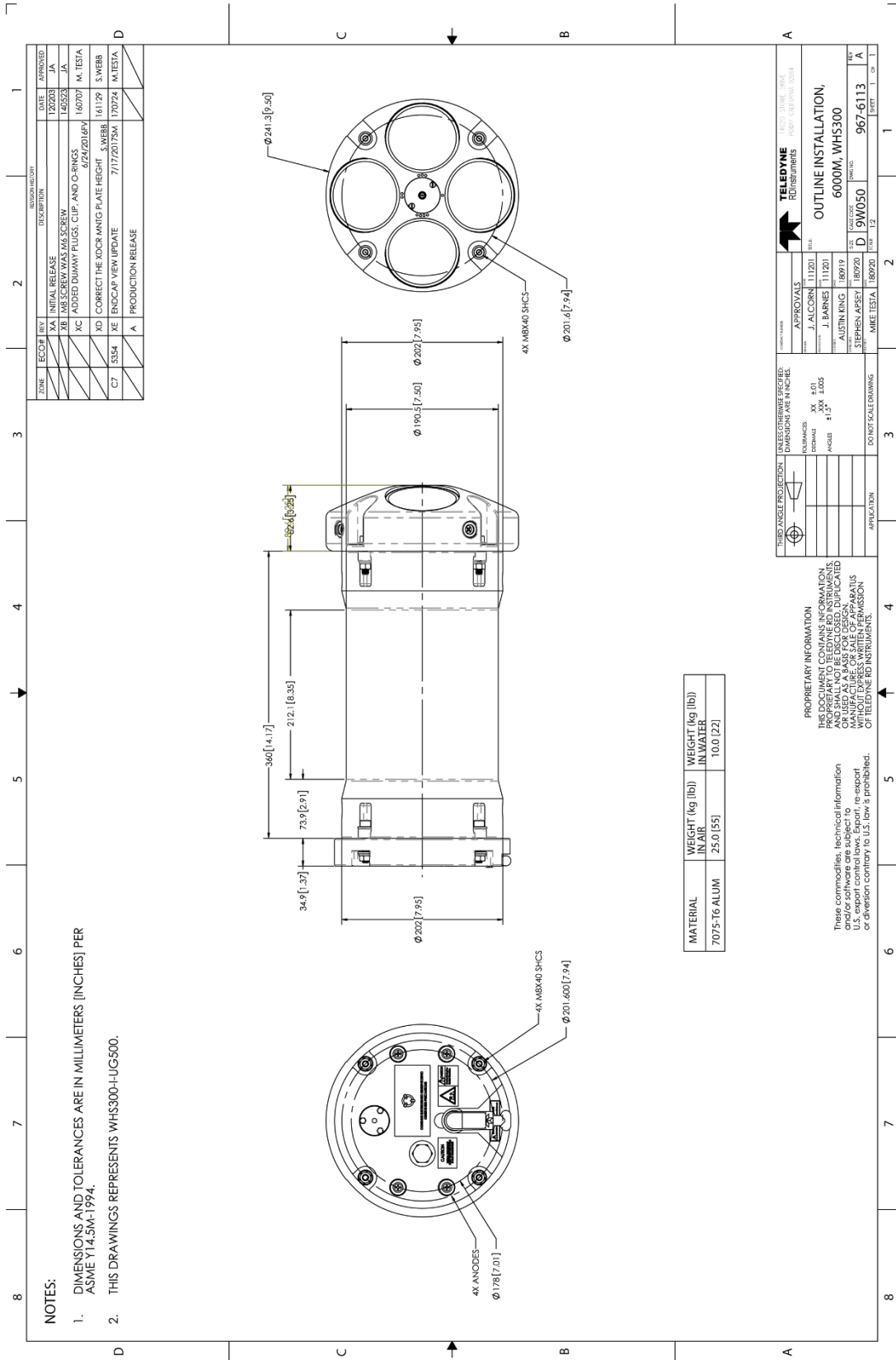




967-6012

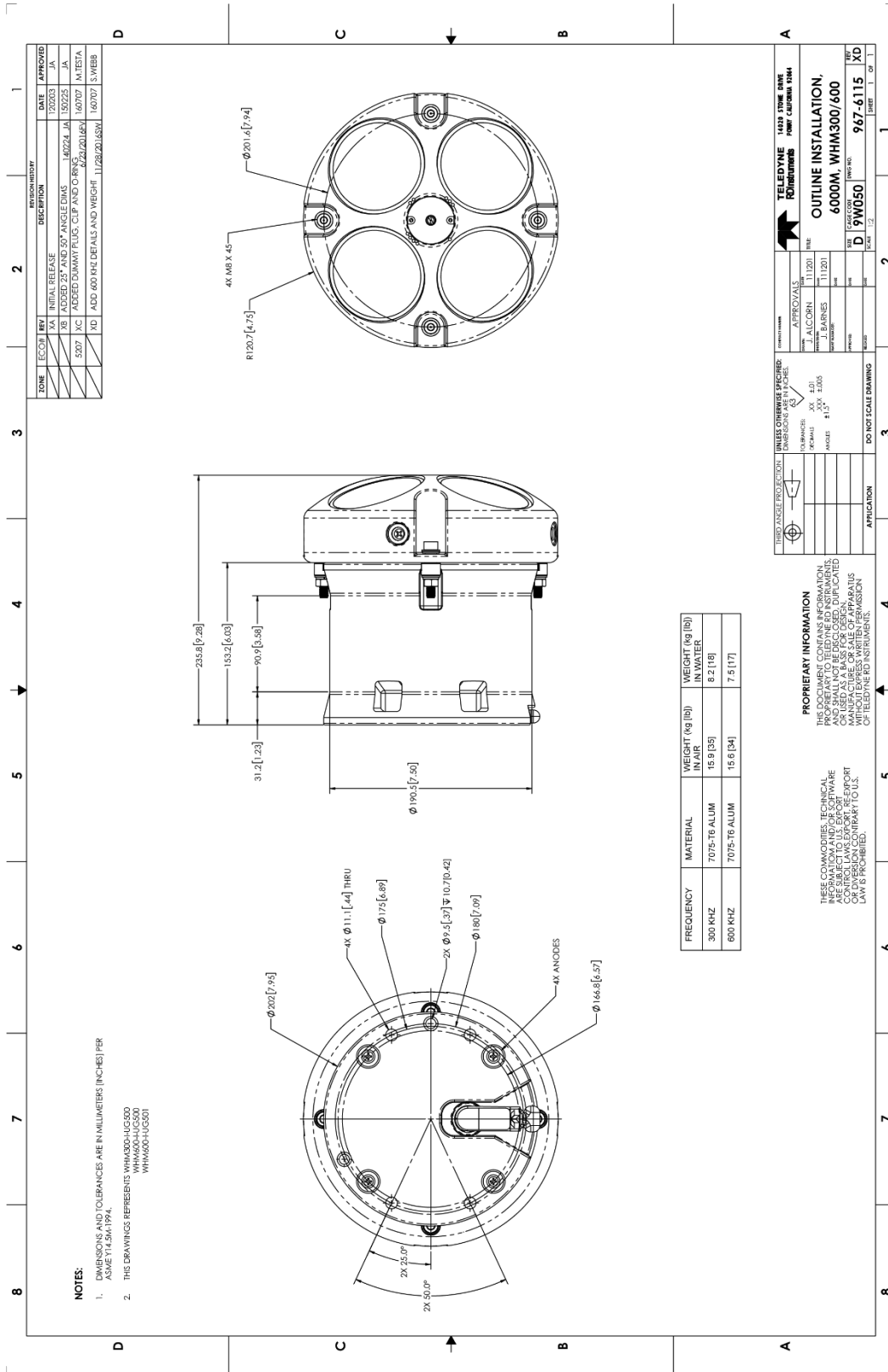


967-6113





967-6115



- NOTES:**
1. DIMENSIONS AND TOLERANCES ARE IN MILLIMETERS (INCHES) PER ASME Y14.5M/1994.
  2. THIS DRAWING REPRESENTS WHM300-1UG300 WHM600-1UG300 WHM600-1UG301

**PROPRIETARY INFORMATION**  
 THESE COMMODITIES, TECHNICAL DATA, AND INFORMATION ARE PROPRIETARY TO TELEDYNE RD INSTRUMENTS. ALL RIGHTS ARE RESERVED. NO PART OF THIS DOCUMENT IS TO BE REPRODUCED, COPIED, DULICATED, MANUFACTURED, OR SALE OF APPARATUS OR INSTRUMENTS IN VIOLATION OF THE LAW IS PROHIBITED.

**APPROVALS**

DESIGNER	J. ALCORN	DATE	11/20/11
DRAWN	J. BARNES	DATE	11/20/11

TELEDYNE RD INSTRUMENTS  
 1422 STONE ISLAND ROAD  
 FOURMORRIS, NJ 08033  
 USA





NOTES



# Appendix **A**

## NOTICE OF COMPLIANCE



In this chapter, you will learn:

- China RoHS requirements
- Material disclosure table

# Date of Manufacture

China RoHS requires that all Electrical and Electronic Products are marked with a Date of Manufacture. This is the starting point for the Environmental Friendly Use Period, described below.

# Environmental Friendly Use Period (EFUP)

Per SJ/T 11364-2006 – Product Marking, the EFUP is defined as the time in years in which hazardous/toxic substances within Electrical and Electronic Products (EIP) will not, under normal operating conditions, leak out of the Product, or the Product will not change in such a way as to cause severe environmental pollution, injury to health, or great damage to property. TRDI has determined the Environmental Friendly Use Period shall be Ten (10) years.

The purpose of the marking is to assist in determining the restricted substance content, recyclability, and environmental protection use period of our covered products, as required in Chinese law, and does not reflect in any way the safety, quality, or warranty associated with these TRDI products.



Some homogenous substance within the EIP contains toxic or hazardous substances or elements above the requirements listed in SJ/T 11363-2006. These substances are identified in Table 36.

# WEEE



The mark shown to the left is in compliance with the Waste Electrical and Electronic Equipment Directive 2002/96/EC (WEEE).

This symbol indicates the requirement NOT to dispose the equipment as unsorted municipal waste, but use the return and collection systems according to local law or return the unit to one of the TRDI facilities below.

**Teledyne RD Instruments USA**  
14020 Stowe Drive  
Poway, California 92064

**Teledyne RD Instruments Europe**  
2A Les Nertieres  
5 Avenue Hector Pintus  
06610 La Gaude, France

**Teledyne RD Technologies**  
1206 Holiday Inn Business Building  
899 Dongfang Road, Pu Dong  
Shanghai 20122 China

# CE



This product complies with the Electromagnetic Compatibility Directive 89/336/EEC, 92/31/EEC. The following Standards were used to verify compliance with the directives: EN 61326(1997), A1(1998), A2(2001) – Class “A” Radiated Emissions.

# Material Disclosure Table

In accordance with SJ/T 11364-2006, the following table disclosing toxic or hazardous substances contained in the product is provided.

**Table 36. Toxic or Hazardous Substances and Elements Contained in Product**

零件项目(名称) Component Name	有毒有害物质或元素 Toxic or Hazardous Substances and Elements					
	铅 Lead (Pb)	汞 Mercury (Hg)	镉 Cadmium (Cd)	六价铬 Hexavalent Chromium (Cr <sup>6+</sup> )	多溴联苯 Polybrominated Biphenyls (PBB)	多溴二苯醚 Polybrominated Diphenyl Ethers (PBDE)
换能器配件 Transducer Assy.	X	X	O	X	O	O
接收机电路板/数据处理器电路板 Receiver WHP PCB	O	O	O	O	O	O
微处理器电路板/输入输出电路板 PIO PCB	O	O	O	O	O	O
机体装配 Housing Assy.	O	O	O	O	O	O
底座装配 End-Cap Assy.	O	O	O	O	O	O
电池组 Battery Pack	O	O	O	O	O	O
交流电转换器 AC Voltage Adapter	O	O	O	O	O	O
水下专用电缆 Underwater Cable	O	O	O	O	O	O
专用装运箱和泡沫塑料垫 Shipping Case w/Foam	O	O	O	O	O	O

**O:** 表示该有毒或有害物质在该部件所有均质材料中的含量均在 SJ/T 11363-2006 标准规定的限量要求以下。

**O:** Indicates that the toxic or hazardous substance contained in all of the homogeneous materials for this part is below the limit required in SJ/T 11363-2006.

**X:** 表示该有毒或有害物质至少在该部件的某一均质材料中的含量超出 SJ/T 11363-2006 标准规定的限量要求。

**X:** Indicates that the toxic or hazardous substance contained in at least one of the homogeneous materials used for this part is above the limit requirement in SJ/T 11363-2006.

NOTES